

AIR CLEANERS

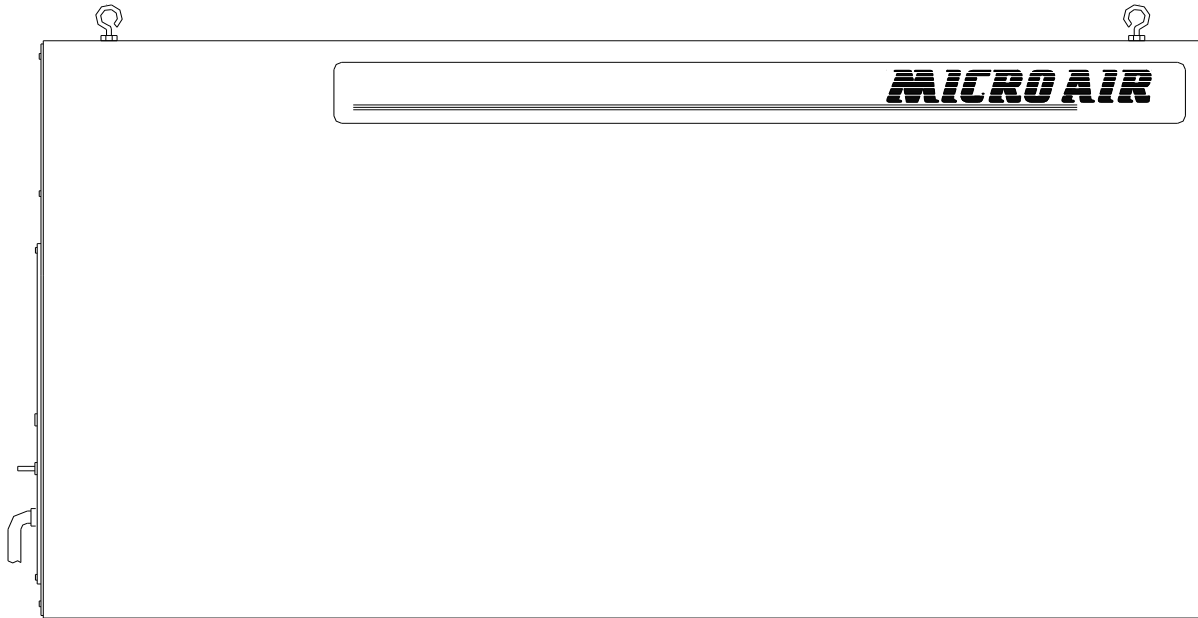

Model MX 1800

OWNER'S MANUAL

CAUTION

Read complete instructions before operating.
Please file for future reference.

MODEL MX 1800 SPECIFICATION

Input Volts:	120V/230V 50Hz/60Hz
Max. Current:	11.2 Amps (At 120V., 3/4hp, Single Phase) 5.0 Amps (At 230V., 3/4hp, Single Phase)
Motor:	2-Speed, Thermally Protected
Dimensions:	24" h. X 24" w. X 45" l.
Shipping Wt:	163 lbs.
Actual Wt:	143 lbs.

PRE-OPERATING INSTRUCTIONS

1. After removing the cardboard carton and plastic wrap from the unit, lift unit from the skid and lay in a horizontal position with the outlet grille towards the bottom side.
2. Inspect the power cord and the on/off switch for damage.
3. Report any freight damage to freight company.

HANGING INSTRUCTIONS

1. Remove the hanger kit from the Owners Manual envelope which contains four (4) threaded eyebolts and the hex nuts.
2. Thread a nut onto each eyebolt and thread an eyebolt into each of the four (4) threaded holes in the cabinet. Tighten nuts against the cabinet.

NOTE: If hanging MX 1800 upside down is required, remove the four (4) 1/4" hex bolts from bottom of cabinet and relocate to top four corners. Then place the four (4) eyebolts into bottom panel of cabinet.

3. Once eyebolts are secured, the MX 1800 is ready to be hung in an appropriate location (See **FIGURE 1**).

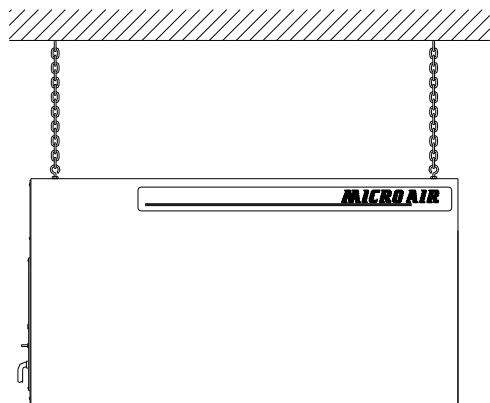

FIGURE 1

4. For vertical installation, use the optional vertical support bracket kit #34088-04. The support brackets are secured to cabinet by using the 1/4-20 hex bolts supplied with the MX 1800 (See **Figure 2**).

CAUTION: Use strong wire or chain to support the air cleaner. Hang from structural supports.

NOTE: If a unit is to be installed on brackets against a wall, use brackets strong enough to hold the unit. Install brackets securely into

S-HOOKS AND
CHAIN NOT
PROVIDED

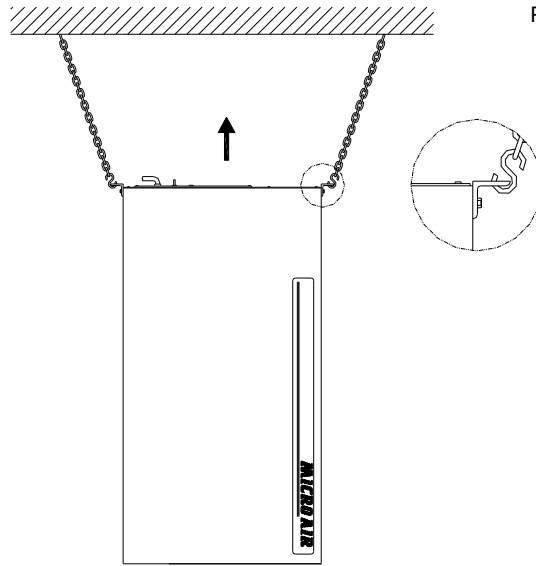

FIGURE 2

OPTIONAL WRAP AROUND PRE-FILTER

The MX 1800 wrap around pre-filter (WAP) is an optional pre-filter that is used to increase filter capacity and extend the life of the primary filter. The WAP is shipped separately from the MX 1800, and therefore requires assembly prior to installation. Use the following steps to install the WAP:

1. Remove 4" pleated pre-filter from MX 1800.
2. Remove the spring latch from MX 1800 as shown in **FIGURE 3**.

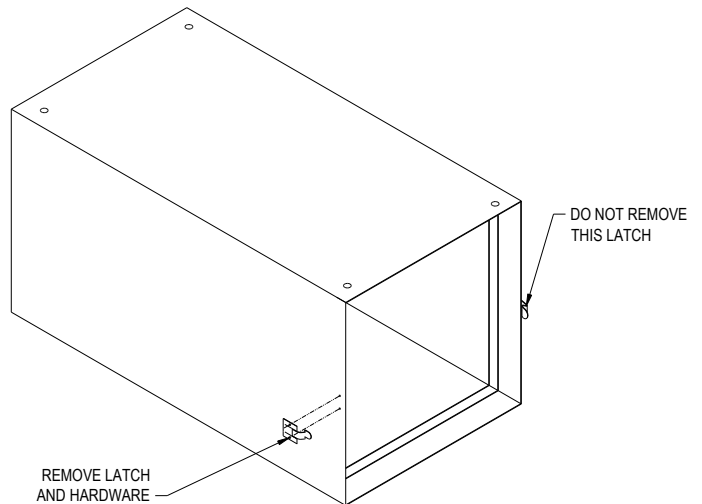

FIGURE 3

- Locate WAP next to MX 1800 and secure to cabinet using the ¼" hardware provided.

NOTE: ¼" nuts and lock washers are located external to the cabinet (See Figure 4).

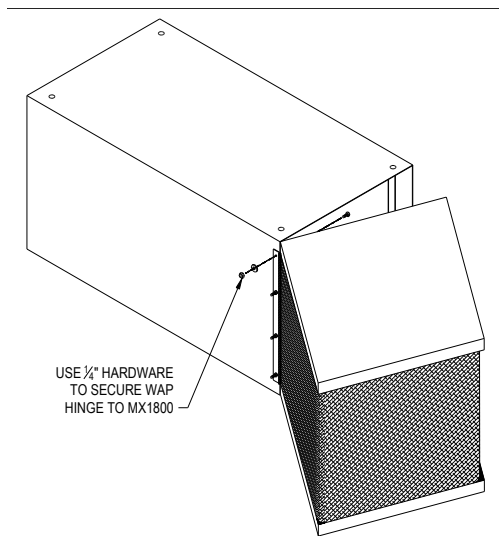

FIGURE 4

- Re-install the 4" pleated pre-filter removed from Step 1.
- Swing the WAP closed and retain WAP to MX 1800 with remaining spring latch.

OPERATING INSTRUCTIONS

- For 115V. 50Hz/60Hz plug is included with power cord. Plug into outlet. Turn the switch on. The unit should now be operational.
- For 230V. 50Hz/60Hz, plug is not included with power cord. Attach 250V. plug with desired Nema Configuration. Plug into outlet. Turn the switch on. The unit should now be operational.

CHANGING FILTERS

CAUTION: Always make sure that the unit is turned off before changing filters or servicing the unit.

- The MX 1800 is equipped with a filter change light which indicates when a filter needs to be replaced.
- When the light comes on, turn the unit off and remove the pre-filter only. Replace with a new pre-filter, making sure that the air flow directional arrow is pointing toward the outlet end. Turn the unit back on. If the filter change light is off, then the unit is operating properly.
- If the filter change light fails to go out after replacing the pre-filter, then the media bag filter also needs to be replaced.
- To install a new bag filter, turn the unit off. Remove the filter and insert a new filter.
- Start the unit. The filter change light should be off, and the unit operating properly.

FILTER CHANGE LIGHT ADJUSTMENTS

The pressure switch which turns the light on with a differential pressure increase, is pre-wired on all models. The pressure switch is pre-set at the factory to indicate (light on) dirty filters and an air flow drop of approximately 67%. If the switch needs readjustment due to a desire for earlier or later filter changes, or a different combination of filters, this is easily done by removing the hole plug in the top of the unit for access to the adjustment screw. Turn the unit on and place a piece of cardboard

over the intake, covering about 80 to 85% of the intake area. With a standard screwdriver, turn the adjustment screw clockwise until the light goes off, or counter-clockwise until the light comes on.

For more time between filter changes (less air flow), cover slightly more of the opening, and for less time between filter changes (more air flow), cover less of the opening.

During the operation, the filter light coming on indicates that the filters need attention. Replace only the pre-filter first and see if the light goes out. If not, replace the bag filter as well.

MX 1800 SILENCER INSTALLATION INSTRUCTIONS

CAUTION: THIS INSTALLATION CAN CAUSE EXPOSURE TO LIVE PARTS. DISCONNECT ELECTRICAL POWER TO UNIT BEFORE PROCEEDING WITH INSTALLATION.

Installation:

1. Unpack and inspect parts for any possible damage incurred during shipping.
2. Remove exhaust grille from unit.
3. Remove screws from exhaust panel, along top, bottom and one (1) side (9 places).
4. Place Silencer over exhaust panel as shown in **Figure 5**.
5. Align holes on unit with the Silencer, and screw into place using screws previously removed from exhaust panel.

Note: Three (3) new holes will have to be drilled on side of pilot light and switch.

6. Screw grille onto Silencer. Installation is complete.

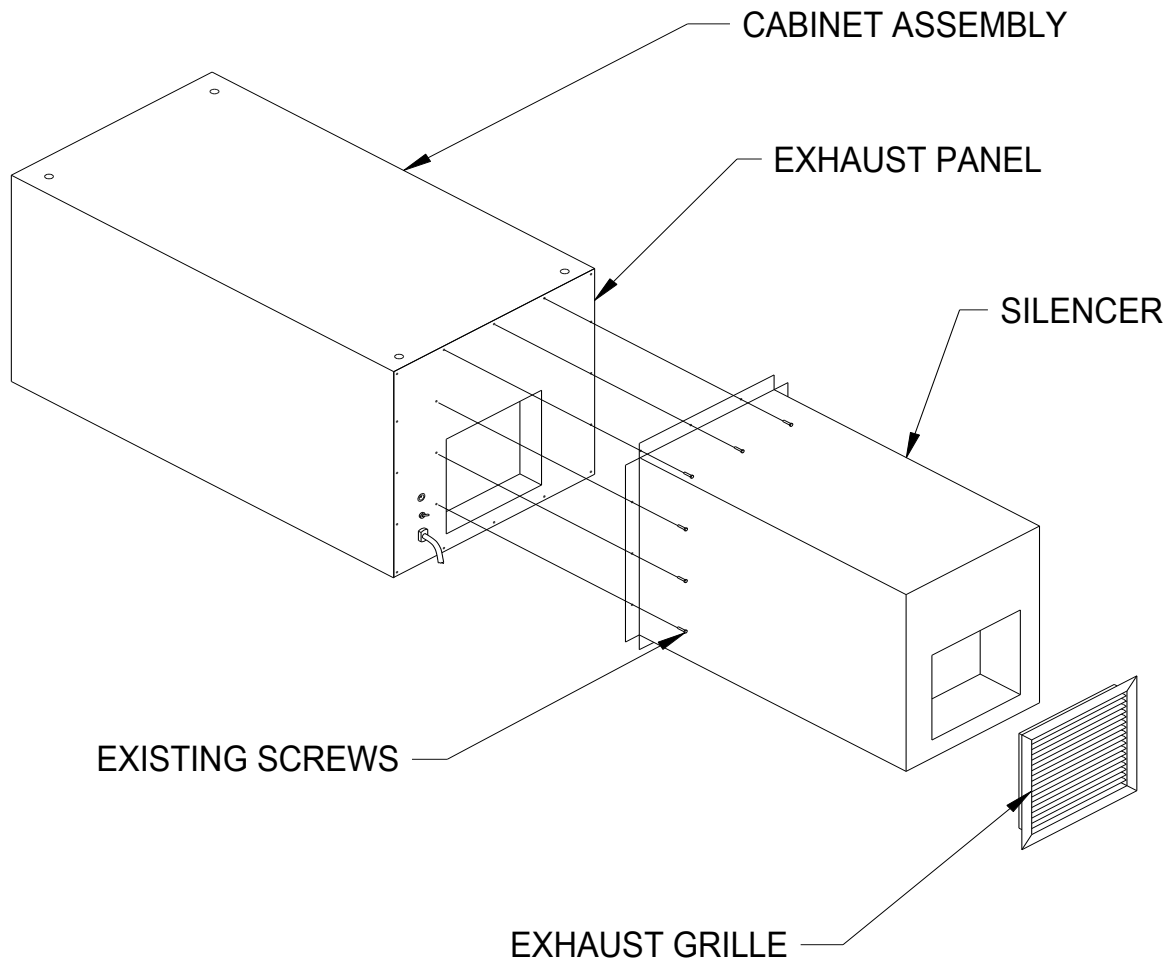

FIGURE 5

MODEL MX 1800 PARTS LIST

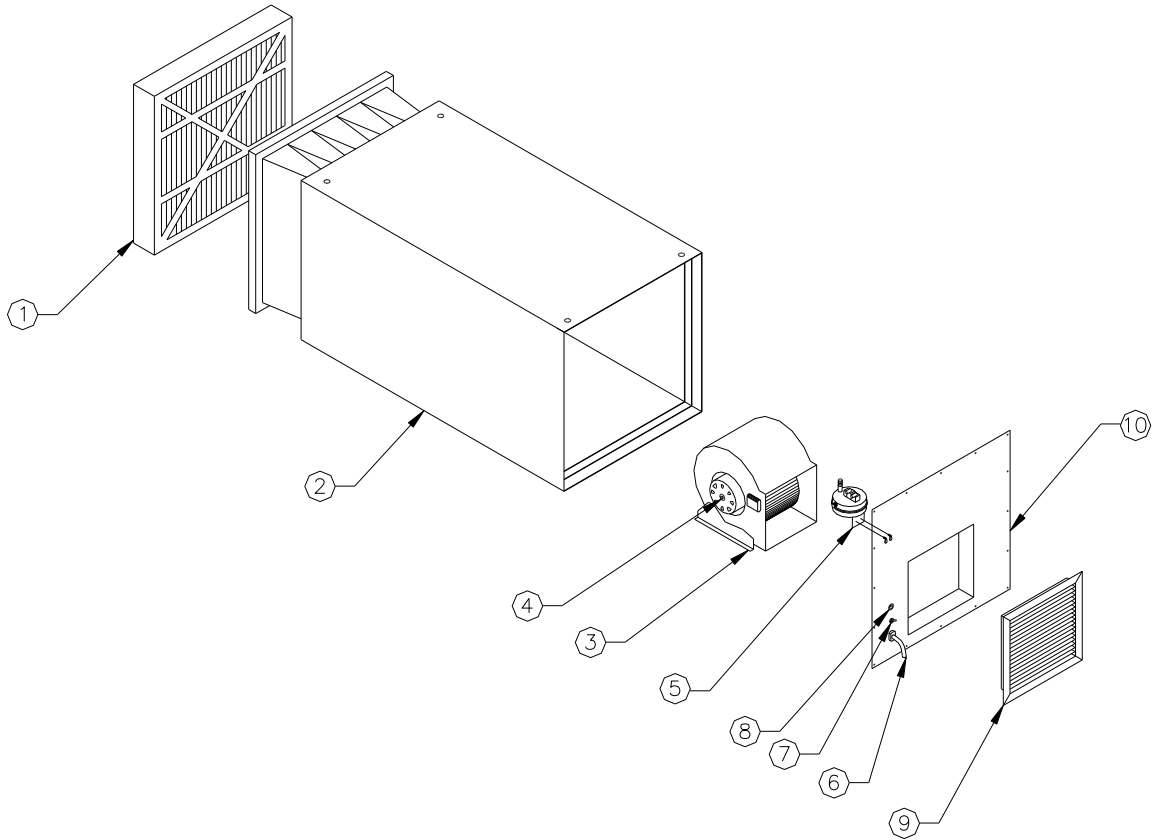

FIGURE 6

ITEM	PART NO.	DESCRIPTION	ITEM	PART NO.	DESCRIPTION
1.	P1411	4" Pleated Pre-Filter	6.	P1363	Cordset (115V)
2.	33536-02	Cabinet Assembly 3/4HP		P345	Cordset (230V)
3.	P1423	Blower	7.	P1354	On/Off Switch
4.	P3604	Motor (120V, 3/4hp)	8.	P1429	Indicator Light (120V)
	P3607	Motor (230V, 3/4hp)		P1481	Indicator Light (230V)
5.	33589-02	Pressure Switch	9.	P1420	Grille
			10.	33594-01	Access Cover Assembly

REPLACEMENT FILTER LIST

PART NO.	DESCRIPTION	PART NO.	DESCRIPTION
P1411	24" X 24" X 4" Pleated Pre-Filter	33605-01	Wrap Around Pre-Filter Module
P1440	24" X 24" X 22" 55% Bag Filter	33608-01	Filter Pad Only for WAP
P1441	24" X 24" X 22" 95% Bag Filter	35017-01	Silencer

