

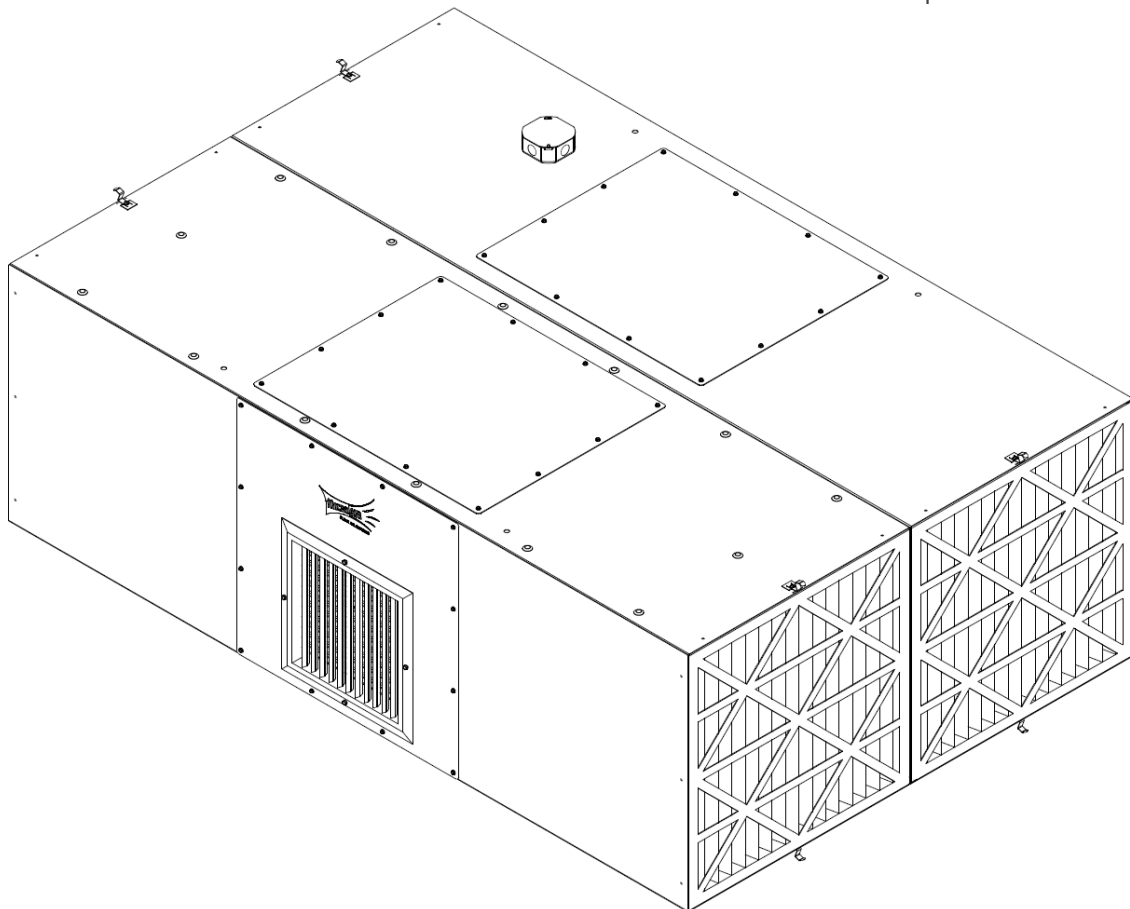

MXT5000/MXT7000

Installation and Operation Manual



This manual contains specific cautionary statements relative to worker safety. Read this manual thoroughly and follow as directed. It is impossible to list all of the hazards of dust control equipment. It is important that use of the equipment be discussed with a Micro-Air Representative. Persons involved with the equipment or systems should be instructed to operate in a safe manner.

WARNINGS:

CAUTION: Installation can cause exposure to live components. Disconnect electrical power before proceeding with installation. Proper Lock Out / Tag Out procedures should be used.



All electrical work must be done by a qualified electrician according to local, state and national codes.



Improper installation or operation of this equipment can cause damage to equipment and / or injury to personnel. The installation / operation manual must be read and followed in its entirety.

MXT5000 SPECIFICATIONS:

Motor:	3 HP, 1760 RPM, TEFC
Input Voltage:	230/460 VAC, 60 Hz, 3-Phase
Max Current:	8.3/4.2 Amps
Blower:	12-9 Belt Driven, 1000 RPM
Air Flow:	5400 CFM
Dimensions:	24" H x 48" W x 72" L
Noise Level:	78 dBA at 6' away from unit
Noise Level w/ Silencer:	70 dBA at 6' away from unit
Shipping Weight:	400 lbs.
Actual Weight:	300 lbs.

MXT7000 SPECIFICATIONS:

Motor:	5 HP, 1765 RPM, TEFC
Input Voltage:	230/460 VAC, 60 Hz, 3-Phase
Max Current:	13.2/6.6 Amps
Blower:	15-9 Belt Driven, 1000 RPM
Air Flow:	7500 CFM
Dimensions:	27" H x 48" W x 72" L
Noise Level:	82 dBA at 6' away from unit
Noise Level w/ Silencer:	75 dBA at 6' away from unit (Non-Louvered)
Noise Level w/ Silencer:	77 dBA at 6' away from unit (Louvered)
Shipping Weight:	450 lbs.
Actual Weight:	350 lbs.

NOTE: The cabinets are designed to be assembled either in a horizontal configuration or a vertical configuration. The mounting options will vary depending on which configuration is selected.

PRE-OPERATING INSTRUCTIONS:

NOTE: The following instructions will vary depending on options ordered.

1. Inspect the unit for any visible damage that may have occurred during shipment. Report any damage to the delivery carrier.
2. Remove the shipping crate, shipping straps and plastic wrap from unit.
3. Remove the unit from the shipping skid and set on a level surface.
4. Remove attachment option from shipping carton.
5. Determine the location where the unit is to be installed. Be sure to allow sufficient access to the unit for servicing and maintenance on all sides.

EQUIPMENT / TOOLS REQUIRED:

- Forklift
- Lifting straps or chains
- Hoist
- Socket wrenches
- Concrete anchors (for wall mount / floor stand)
- Wire nuts

EYEBOLTS HANGING INSTRUCTIONS:

1. Remove the 4 threaded eyebolts and hardware from the Owner's Manual envelope.
2. Place an eyebolt to each of the 4 through holes on top of the cabinet. Use 3/8-16 hex nut and 3/8" washer to fasten to cabinet.
3. Once eyebolts are secured, the MXT is ready to be hung in an appropriate location (See FIGS. 1 & 2).

NOTE: Chain, link or cable should hang vertically.



CAUTION: Use strong braided wire or chain to support the air cleaner. Hang from ceiling / roof structural supports.

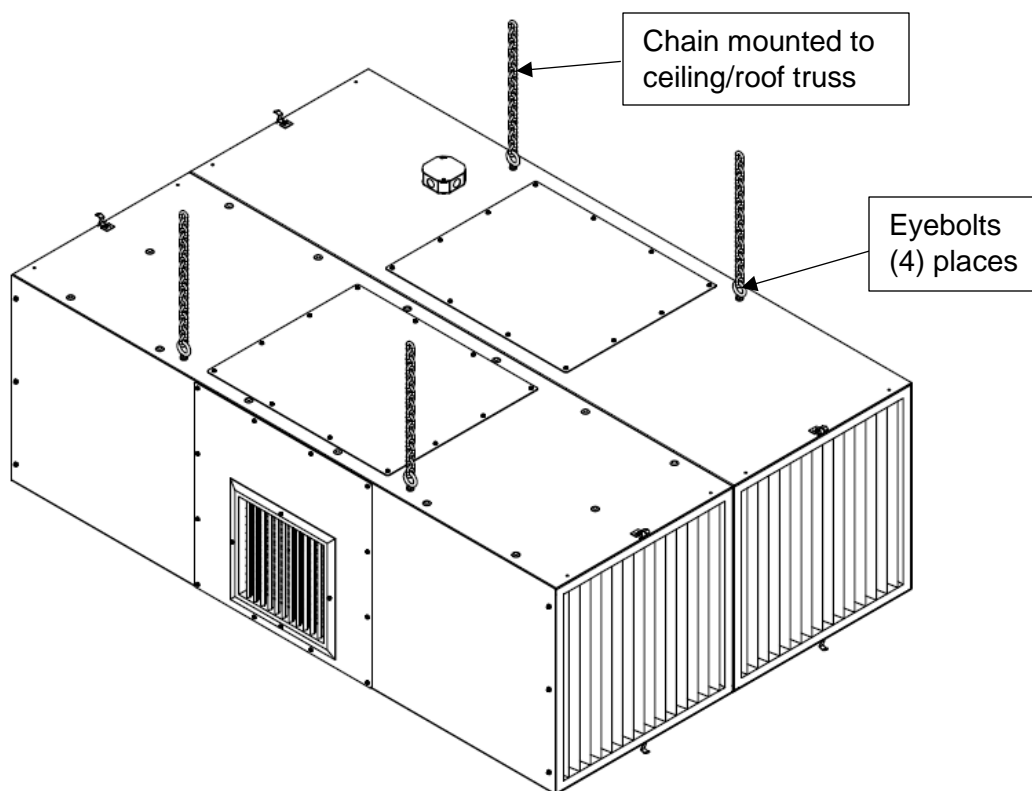

FIG. 1 – Horizontal Configuration.

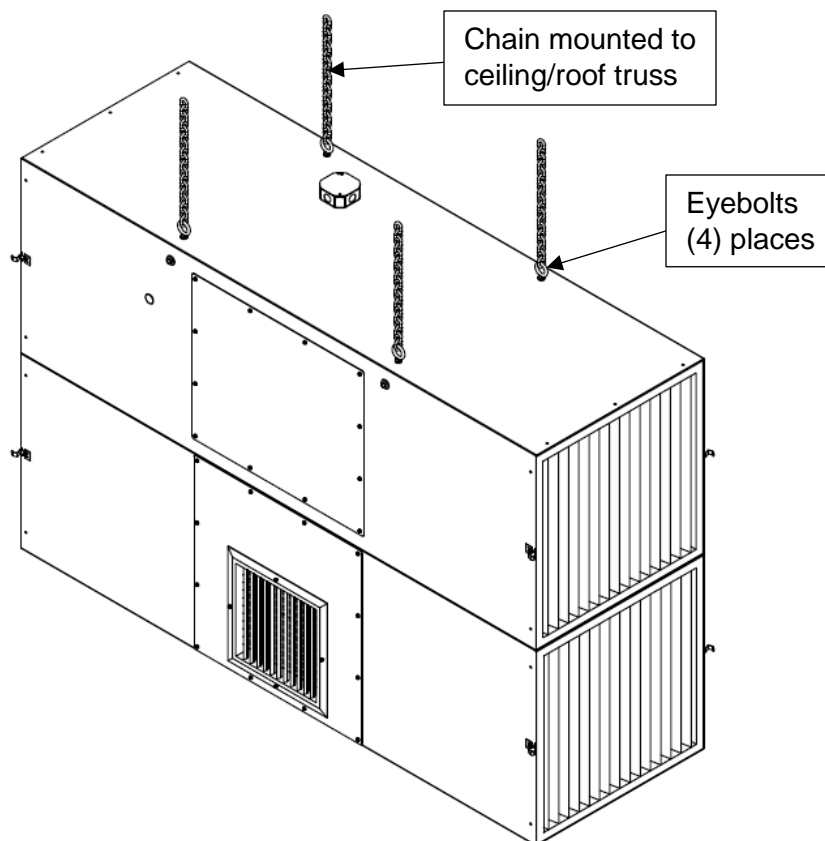

FIG. 2 – Vertical Configuration.

CHANNEL HANGING INSTRUCTIONS:

1. Remove 3/8" hardware from the Owner's Manual envelope.
2. Lift unit to access the threaded holes on the bottom of the cabinet. Depending on the configuration, the number of bolts will be different. The horizontal configuration bolts on 8 places on the bottom of the cabinets whereas the vertical configuration bolts on 4 places. **NOTE:** The cabinet can be lifted by installing eyebolts on the top. Eyebolts are not supplied by Micro Air (See **FIGS. 1 & 2**).
3. Line up mounting channel with holes on bottom of cabinet. Bolt in place.
4. Once channels are secured, the MXT is ready to be hung in an appropriate location (See **FIG. 2**).

NOTE: Chain, link or cable should hang vertically.



CAUTION: Use strong braided wire or chain to support the air cleaner. Hang from ceiling / roof structural supports.

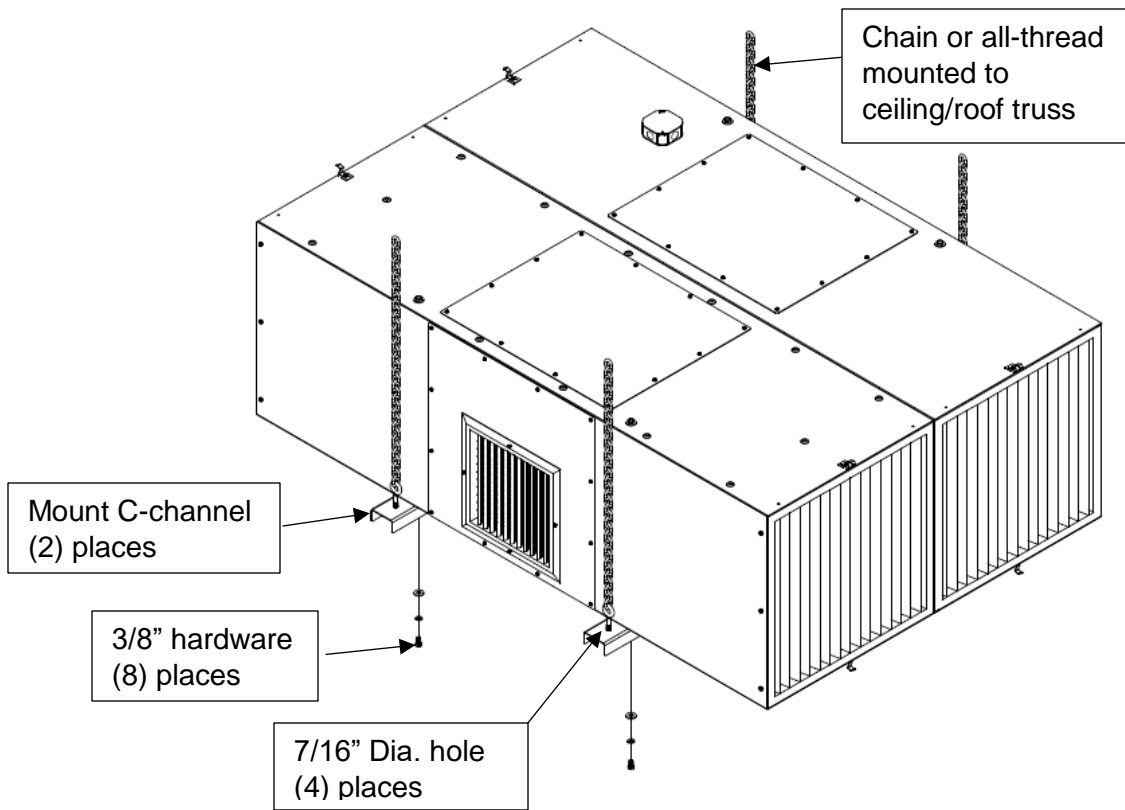

FIG. 3 – Horizontal configuration.

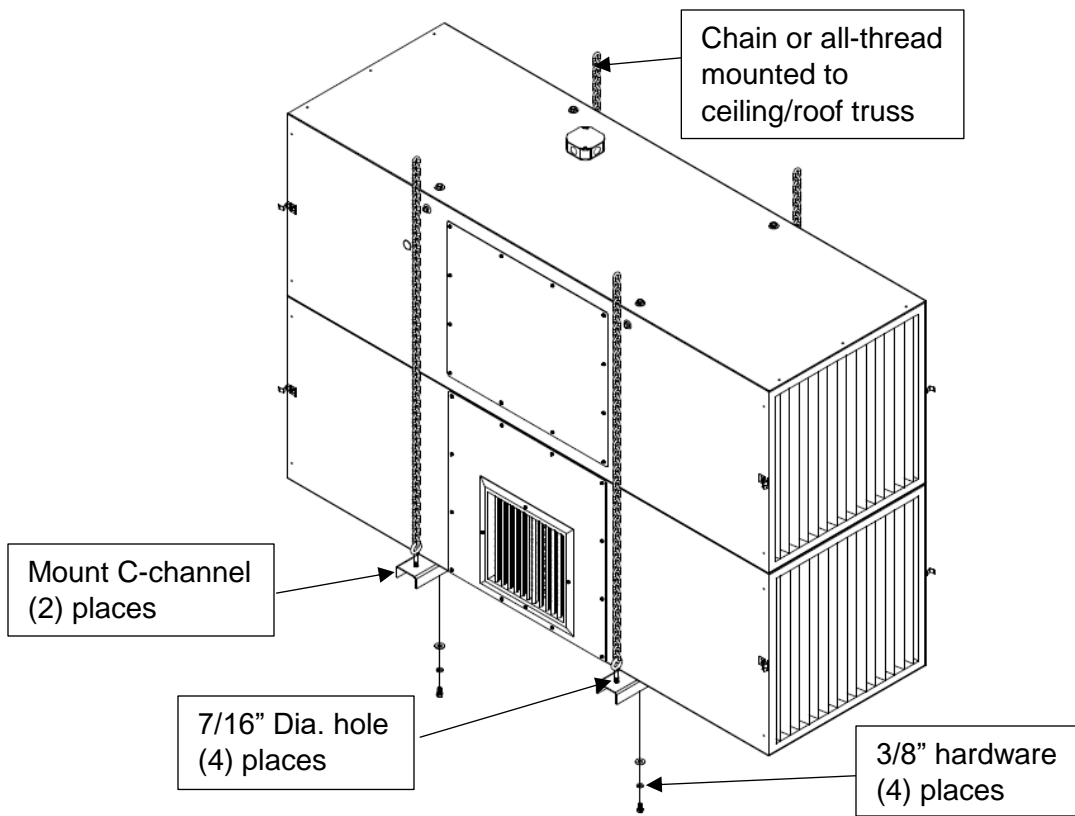

FIG. 4 – Vertical configuration.

WALL MOUNT:

This option is only available for the vertical configuration of the MXT.

1. Remove 3/8" hardware from the Owner's Manual envelope.
2. Install wall mount. The brackets have (8) 7/16" holes to mount to wall (4 holes on each angle). The holes are spaced 16" apart horizontally by 24" vertically. **NOTE:** Anchors are not supplied by Micro Air. Minimum embedment depth for a 3/8" dia. wedge anchor is 1-1/2".
3. Lift unit to access the threaded holes on the bottom of the cabinet. **NOTE:** The cabinet can be lifted by installing eyebolts on the top. Eyebolts are not supplied by Micro Air (See **FIG. 2**).
4. Install cabinet to wall mount by bolting to the bottom of the cabinet with the hardware supplied (See **FIG. 5**).

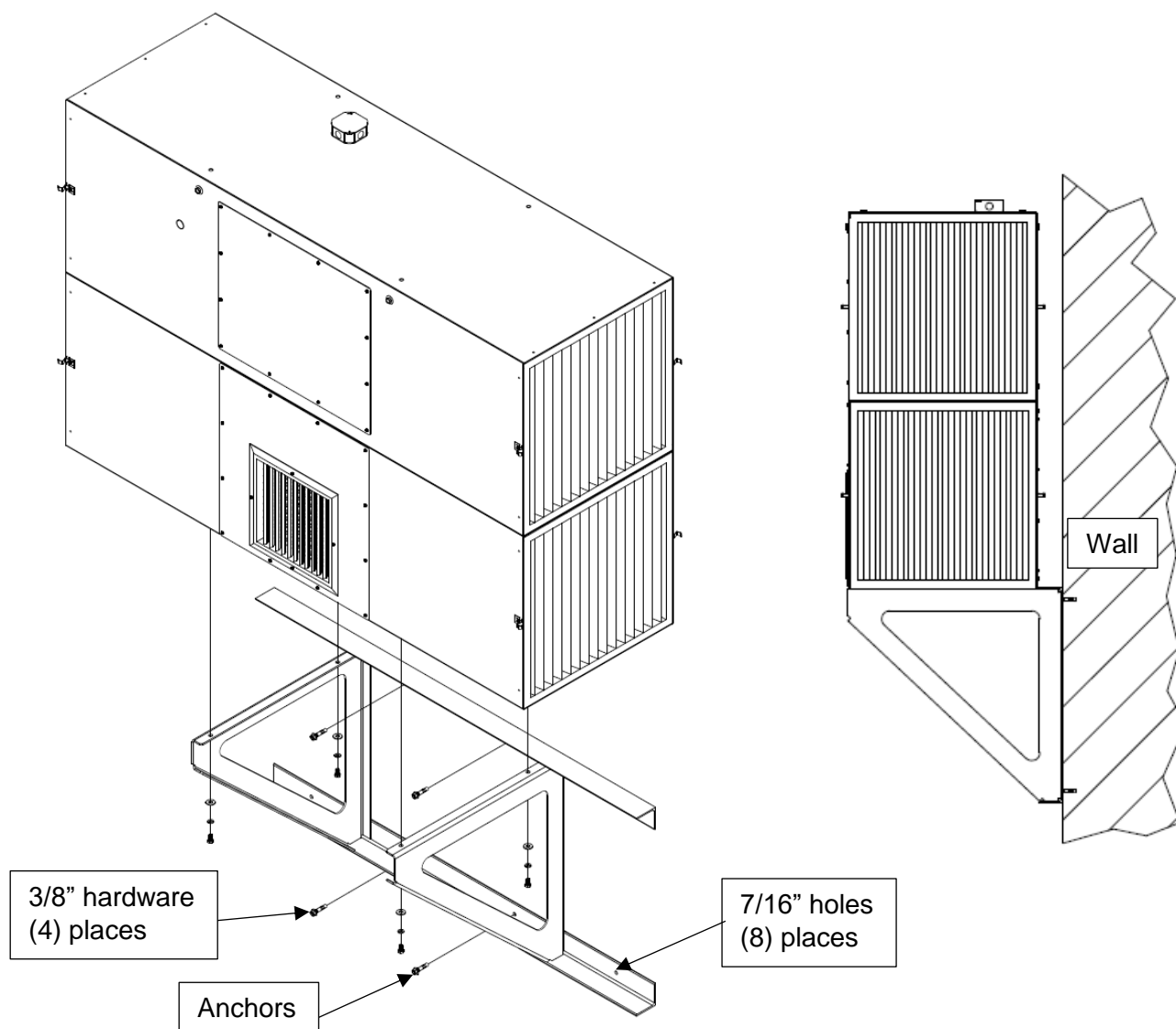

FIG. 5

10' FLOOR STAND:

This option is only available for the vertical configuration of the MXT.

1. Remove 3/8" hardware from the Owner's Manual envelope.
2. Install floor stand. The stand has (4) 5/8" holes to mount to the floor. The holes are spaced 22" apart. **NOTE:** Anchors are not supplied by Micro Air. Typical minimum embedment depth for a 1/2" dia. wedge anchor is 2-1/2".
3. Lift unit to access the threaded holes on the bottom of the cabinet. **NOTE:** The cabinet can be lifted by installing eyebolts on the top. Eyebolts are not supplied by Micro Air (See **FIG. 2**). Install cabinet to floor stand by bolting to the bottom of the cabinet with the hardware supplied (See **FIG. 6**).

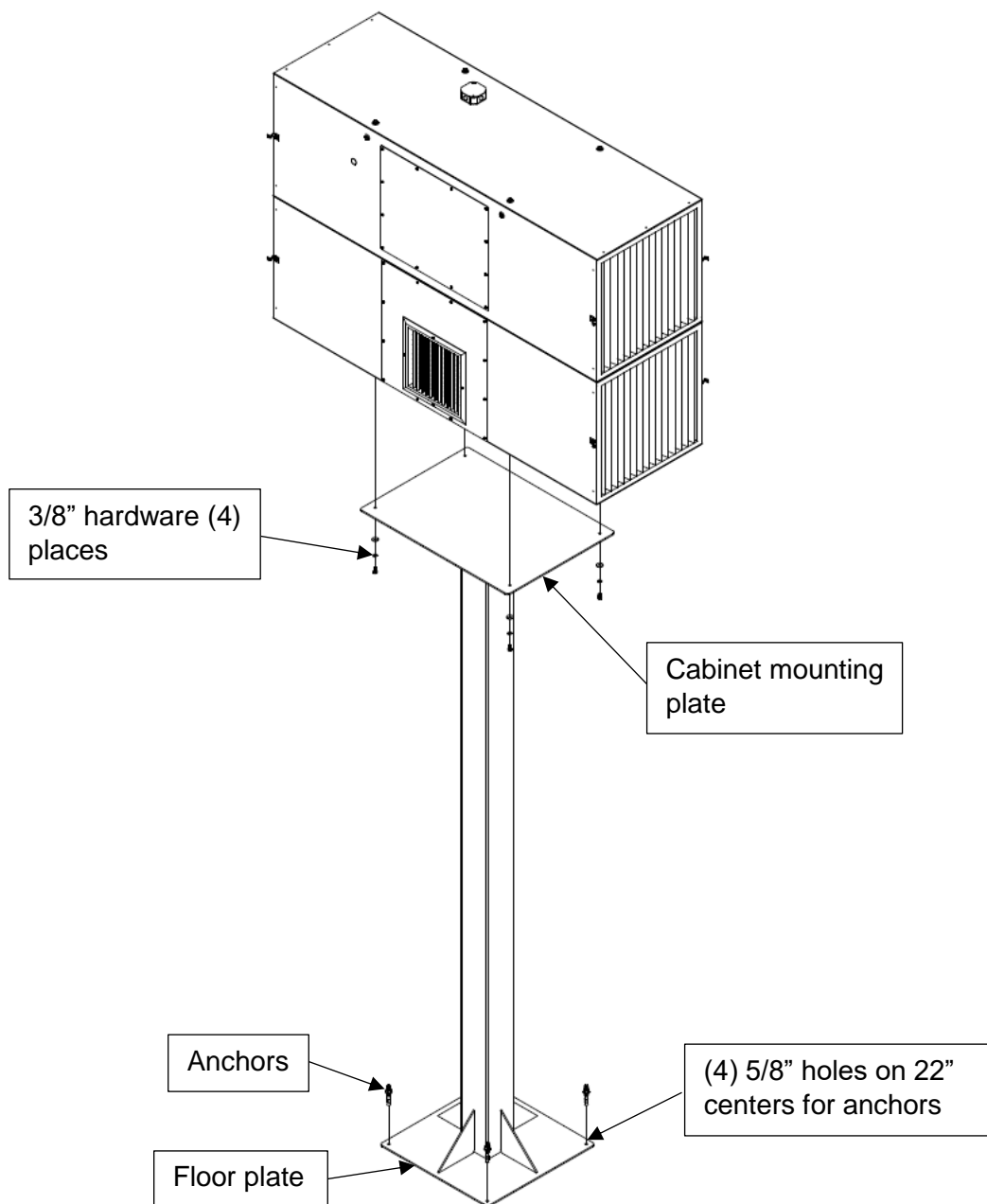

FIG. 6

MXT5000 OPTIONAL SILENCER ASSEMBLY:

Installation:

1. Remove parts from package and inspect for any damage during shipping.
2. Place silencer over exhaust panel.
3. Using supplied self-drilling sheet metal screws, attach silencer. See **FIG. 8** for location of silencer assembly. 16 New holes will have to be drilled on the exhaust panel.

NOTE: If the silencer is bought separate from the MXT unit, the exhaust grille will need to be removed before installing the silencer assembly.

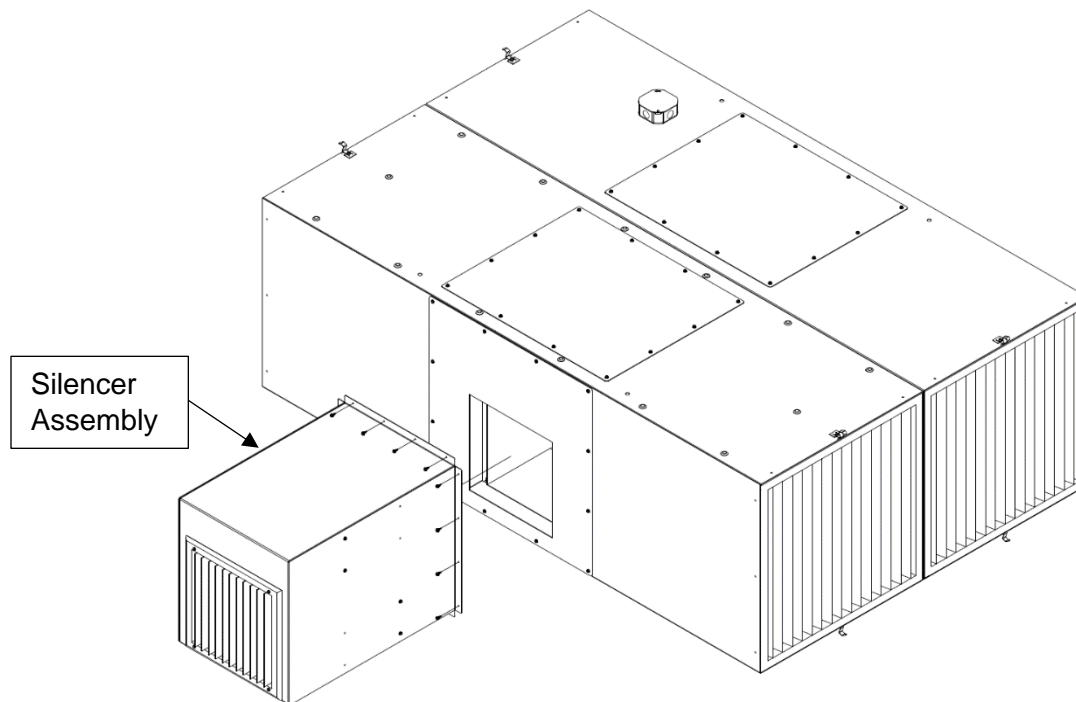

FIG. 7

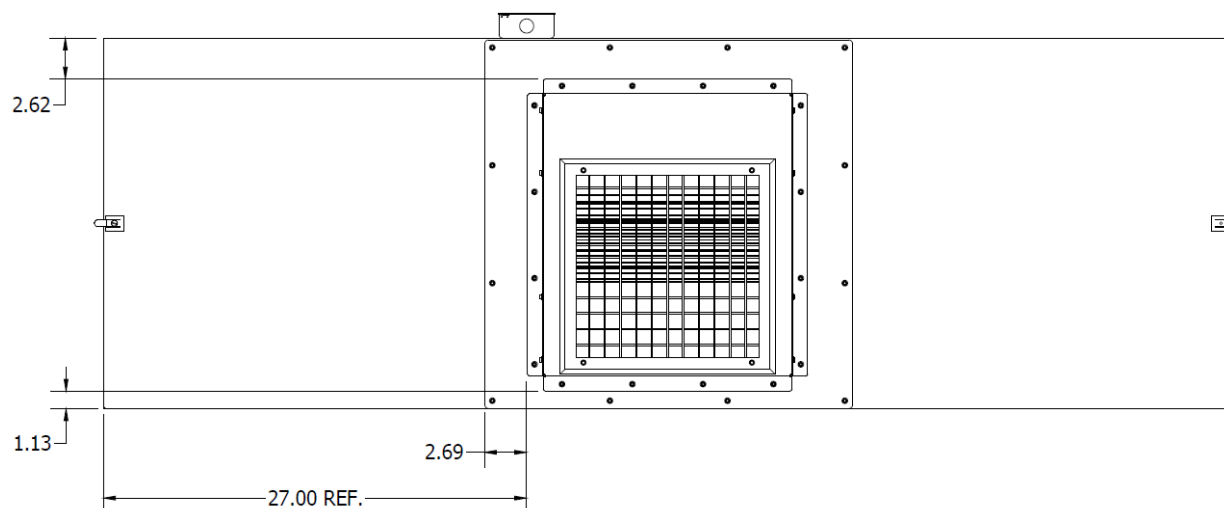

FIG. 8

MXT7000 OPTIONAL SILENCER ASSEMBLY, NON-LOUVERED:

Installation:

1. Remove parts from package and inspect for any damage during shipping.
2. Place silencer over exhaust panel.
3. Using supplied self-drilling sheet metal screws, attach silencer. See **FIG. 10** for location of silencer assembly. 16 New holes will have to be drilled on the exhaust panel.

NOTE: If the silencer is bought separate from the MXT unit, the exhaust grille will need to be removed before installing the silencer assembly.

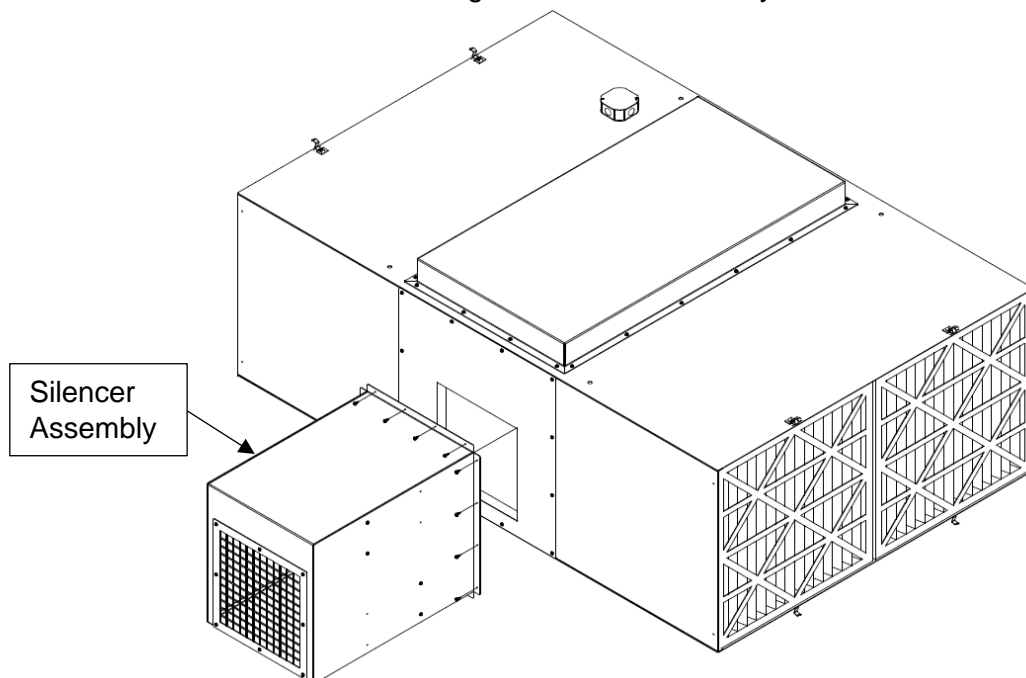

FIG. 9

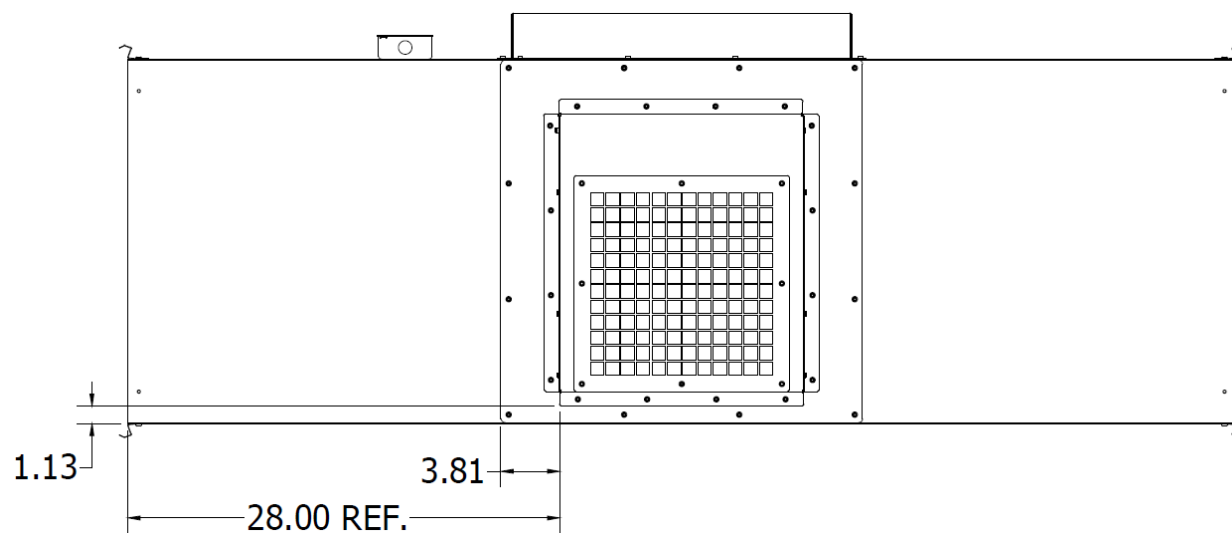

FIG. 10

MXT7000 OPTIONAL SILENCER ASSEMBLY, LOUVERED:

Installation:

1. Remove parts from package and inspect for any damage during shipping.
2. Place silencer over exhaust panel.
3. Using supplied self-drilling sheet metal screws, attach silencer. See **FIG. 8** for location of silencer assembly. 16 New holes will have to be drilled on the exhaust panel.

NOTE: If the silencer is bought separate from the MXT unit, the exhaust grille will need to be removed before installing the silencer assembly.

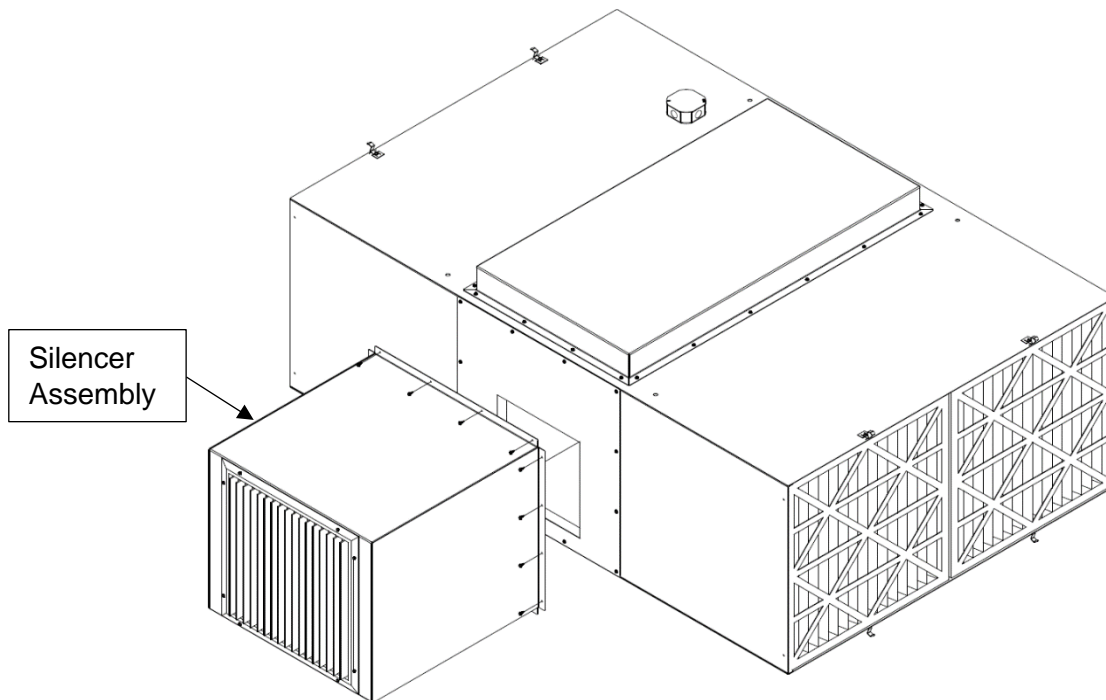

FIG. 11

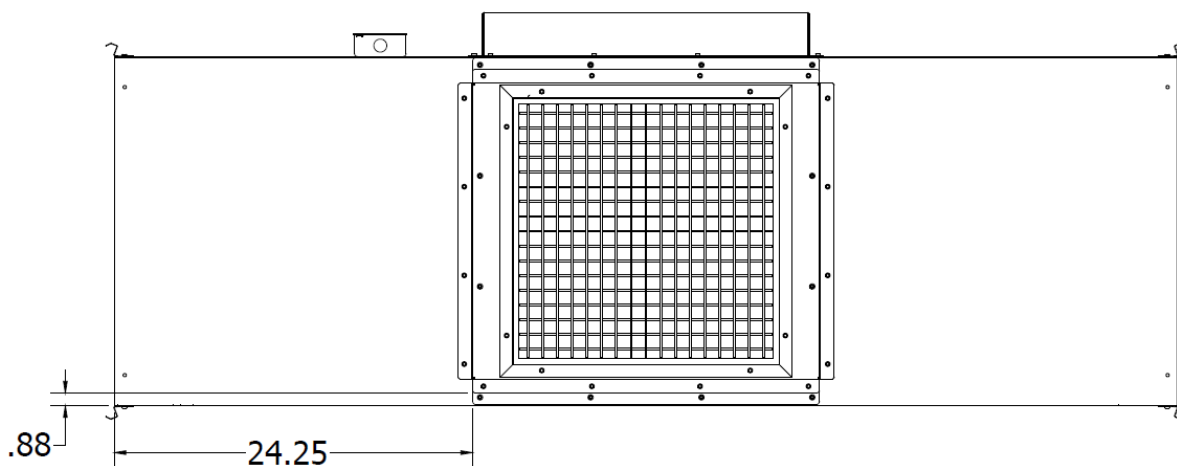

FIG. 12

OPTIONAL SCRIM PRE-FILTER:

In order to access the filters, the Scrim pre-filter will need to be removed. Disengage the latch from the scrim pre-filter (8 places per side). The scrim pre-filter will be installed from the factory when purchased with the unit.

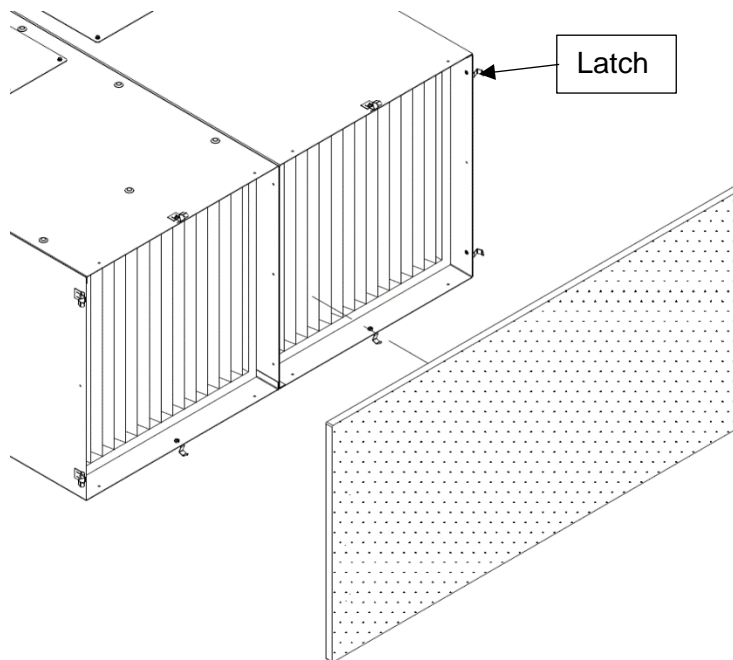

FIG. 13 – Horizontal Configuration.

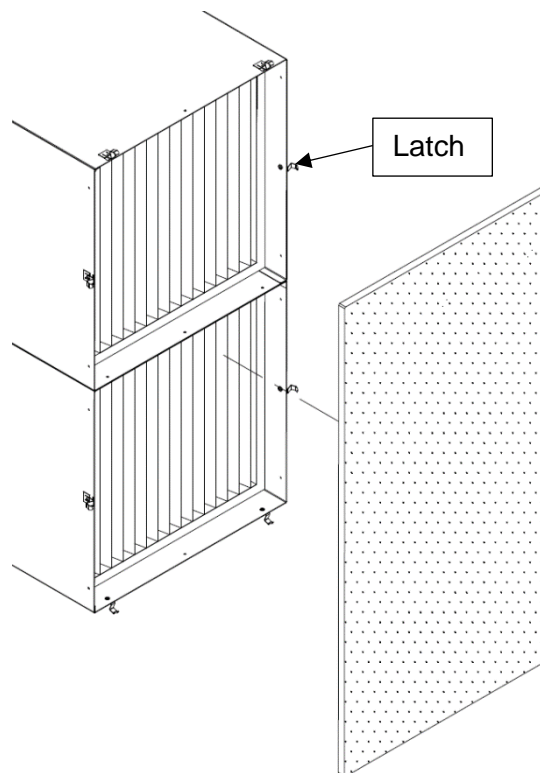

FIG. 14 – Vertical Configuration

OPTIONAL MAGNAHELIC GAUGE:

Installation:

1. Remove parts from package and inspect for any damage during shipping.
2. Mount the Magnahelic Gauge into the mounting bracket and place the male barb fittings in the pressure ports on the side of the gauge. **NOTE:** The bracket can be mounted in any flat surface. Additional air hose can be purchased from the factory.
3. Plug the two ports on the back of the gauge.
4. Mount the bracket using the (4) self-tapping screws.
5. Using $\frac{1}{4}$ " clear tubing connect the "LOW" pressure port on the gauge to the pre-installed barb fitting on the unit. The "HIGH" pressure port stays disconnected. **NOTE:** The Magnahelic assembly will be installed from the factory when purchased with the unit.

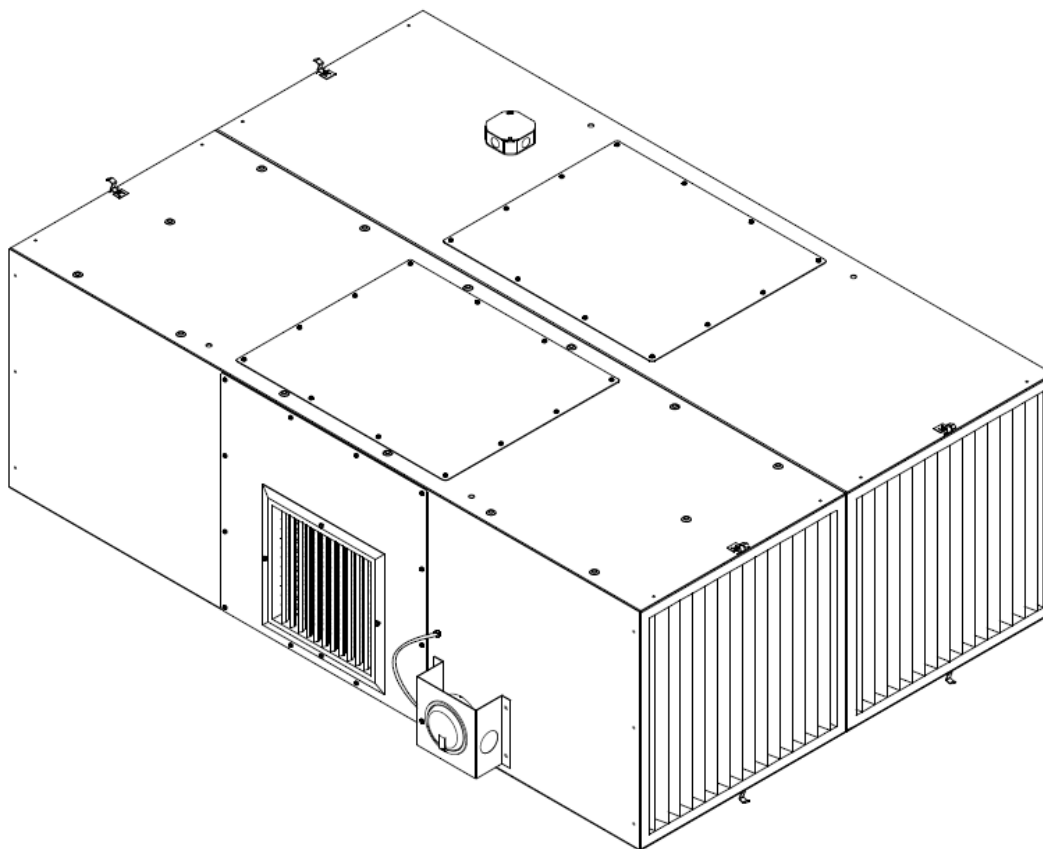

FIG. 15

ELECTRICAL INSTALLATION:

⚠ All electrical work must be done by a qualified electrician according to local, state and national codes.

1. Remove the electrical box cover located on the top side of the unit.
2. Make electrical connections as shown in wiring diagram to the wires protruding from junction box.
3. Check current draw of the motor. Do not exceed Amps specified.

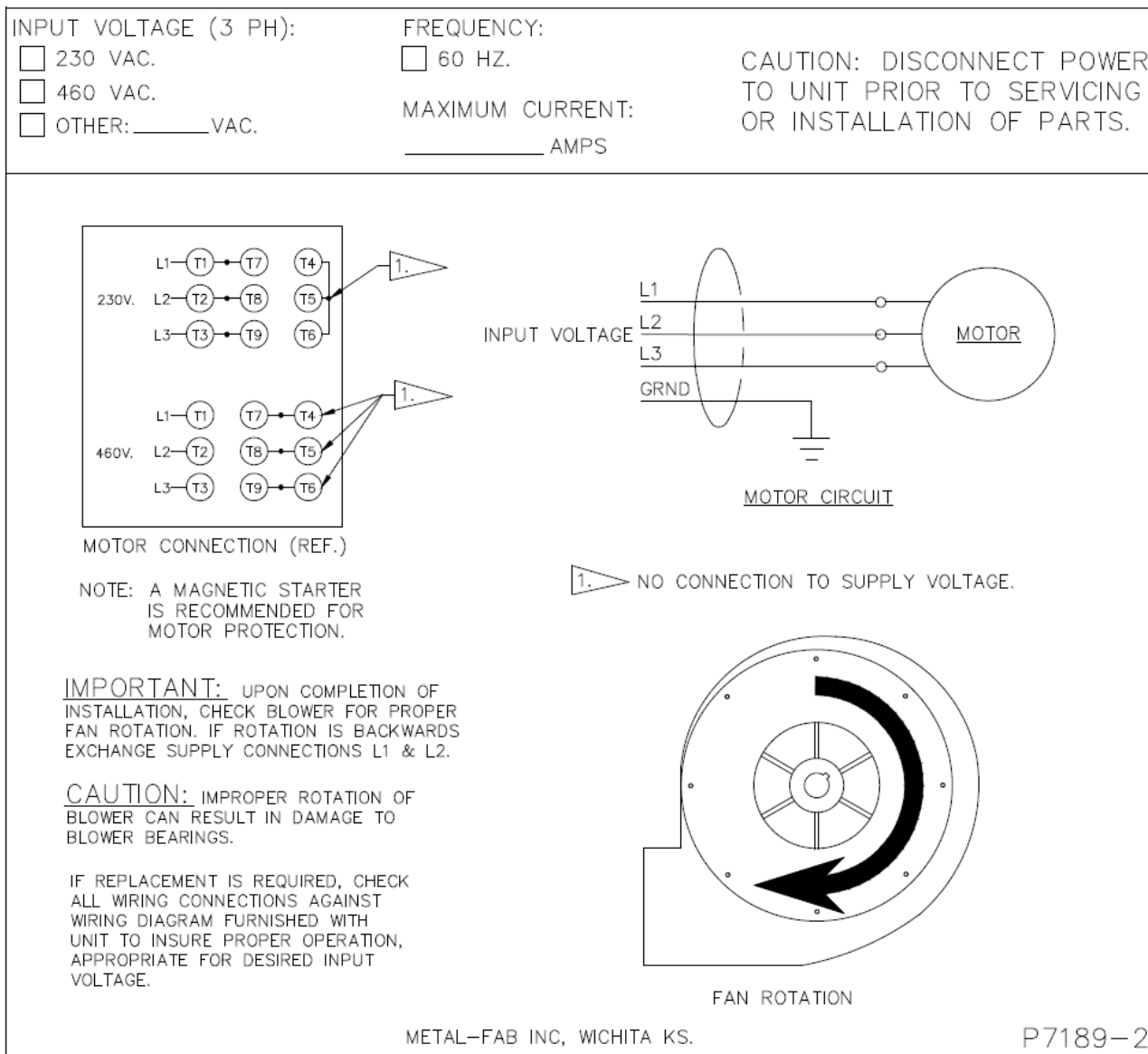

FIG. 16

CHANGING THE FILTERS:

As the filters collect airborne pollutants, they will eventually become “loaded,” which will cause airflow to decrease.



CAUTION: Always make sure that the unit is turned off before changing filters or servicing the unit.

1. Turn the unit off.
2. Disengage latches and remove the pleated pre-filters. **NOTE:** Replace the pre-filters only. If the unit airflow is back to normal, the unit is operating properly and there's no need to replace the main filters.
3. Visually inspect the main filters. If the filters show excessive particulate build-up, they will need to be replaced.
4. Pull the filter from the unit.
5. Install new filter and pre-filter. Make sure that the airflow directional arrow on the pleated pre-filter is pointing towards the inside of the cabinet.
6. Engage latches to secure pre-filters.

NOTE: For units equipped with the optional Scrim Pre-Filter, remove the scrim pre-filter by disengaging the latches (See **FIGS. 13 & 14**).

For units equipped with the Magnahelic Pressure Gauge:

1. The magnahelic gauge indicates the static pressure. Note the reading at initial start-up. As the filters become “loaded,” the static pressure will gradually increase. This will indicate the need to change the filters. **NOTE:** Typical pressure range for most applications is 1.0 in-w.g. for the MXT5000 and 2.0 in-w.g. for the MXT7000 until the filters will need to be replaced. Upon start up, the gauge should measure some amount of pressure drop (typically 0.4 in-w.g.). If no pressure is measured, check connections for proper installation.
2. Replace the scrim pre-filters and pleated pre-filters only. If the pressure reading decreases, the unit is operating properly. If the gauge continues to read high after replacing the pre-filters, then the main filters will also need to be replaced.

GENERAL MAINTENANCE:

1. Occasionally check the condition of the drive belt for tightness and wear as well as the condition of the pulleys.
2. Check the blower bearings for unusual wear and the blower wheel for debris and dirt. Clean when necessary.
3. Periodically inspect hardware for loose nuts and bolts on access doors and internal components. Tighten if necessary.
4. Check the wiring for loose connections or cracked insulation.
5. No lubrication is required for the motor.
6. Excessive dirt or oil should be removed periodically.

MXT5000 PARTS LIST (HORIZONTAL CONFIGURATION):

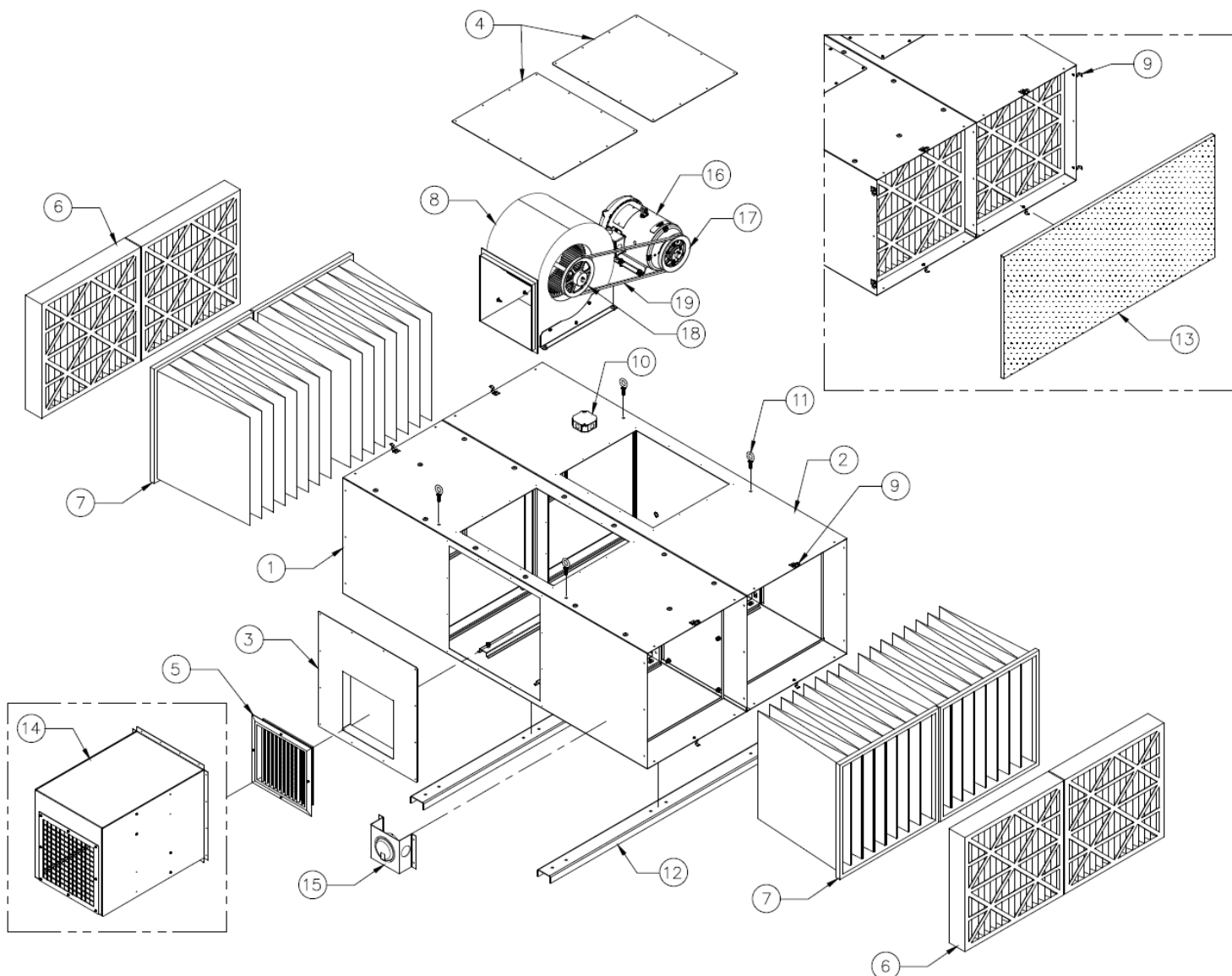

FIG. 17

ITEM	PART NO.	DESCRIPTION	ITEM	PART NO.	DESCRIPTION
1	30651-02	Blower Cabinet Weldment	11*	P2437	Eyebolts
2	30651-03	Motor Cabinet Weldment	12*	30658-02	C-Channel Mount
3	30655-02	Exhaust Panel	13*	30667-02	Scrim Pre-Filter
4	30656-02	Access Panel	14*	30672-01	MXT5 Silencer Assembly
5	P1420	Grille	15*	38294-01	Magnehelic Mount Bracket
6	P1411	Pleated Pre-Filter		P2250	0-5" Magnehelic Gauge
7	P1440	55% Bag Filter			
	P1441	95% Bag Filter			
8	P3498	Blower			
	38080-01	Blower Leg Left			
	38080-02	Blower Leg Right			
9	P335	Latch			
10	P7182	Junction Box			
	P7183	Junction Box Cover			
MXT5000 Drive Package					
			16	P7175	Motor, 3HP, 230/460V
			17	P7194	Motor Pulley
				P3273	1-1/8" Bore Bushing
			18	P3218	Blower Pulley
			19	P7187	V-Belt

*Optional

MXT5000 PARTS LIST (VERTICAL CONFIGURATION):

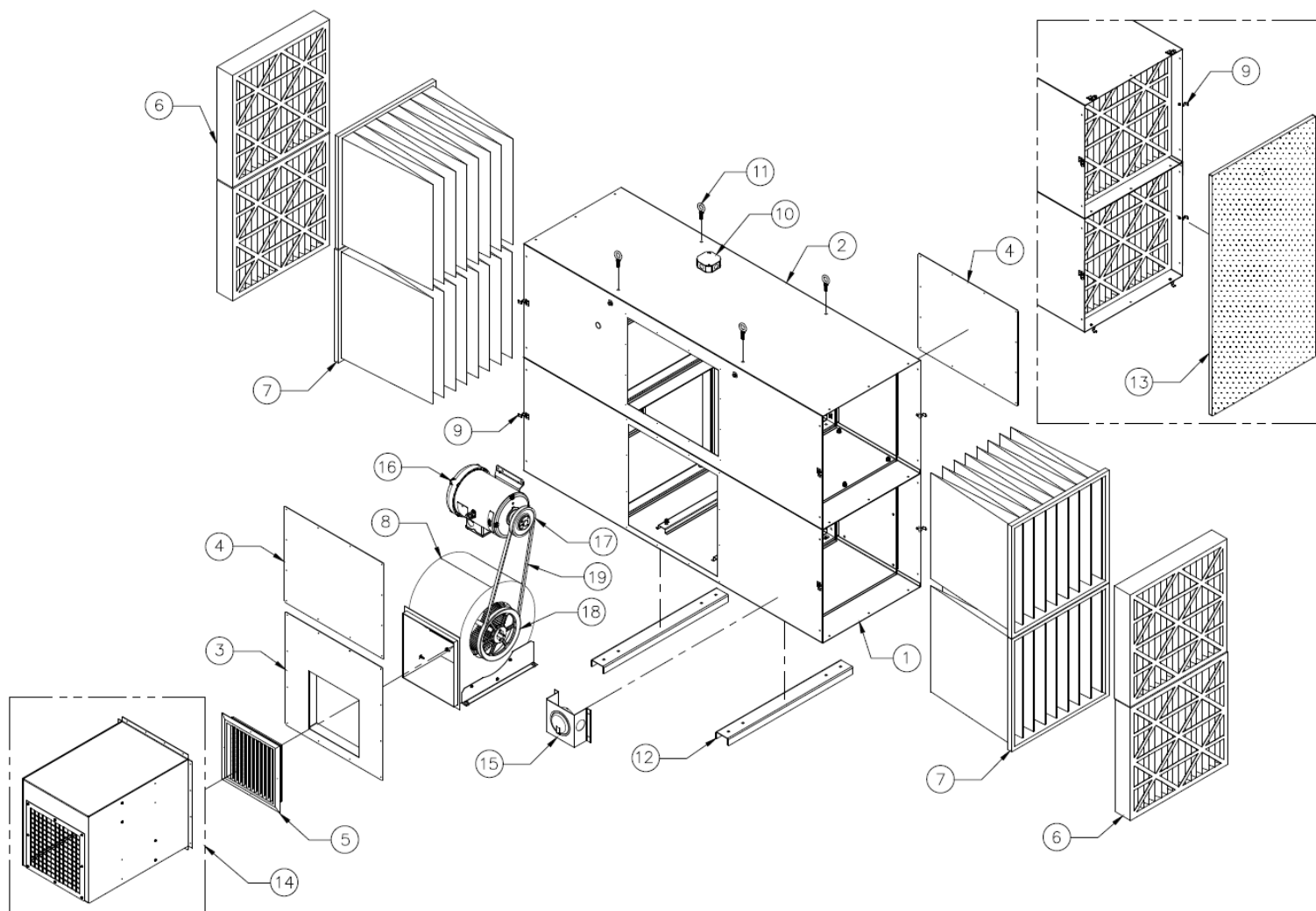

FIG. 18

ITEM	PART NO.	DESCRIPTION
1	30651-02	Blower Cabinet Weldment
2	30651-03	Motor Cabinet Weldment
3	30655-02	Exhaust Panel
4	30656-02	Access Panel
5	P1420	Grille
6	P1411	Pleated Pre-Filter
7	P1440	55% Bag Filter
	P1441	95% Bag Filter
8	P3498	Blower
	38080-01	Blower Leg Left
	38080-02	Blower Leg Right
9	P335	Latch
10	P7182	Junction Box
	P7183	Junction Box Cover

*Optional

ITEM	PART NO.	DESCRIPTION
11*	P2437	Eyebolts
12*	30658-02	C-Channel Mount
13*	30667-02	Scrim Pre-Filter
14*	30672-01	MXT5 Silencer Assembly
15*	38294-01	Magnehelic Mount Bracket
	P2250	0-5" Magnehelic Gauge

MXT5000 Drive Package

16	P7175	Motor, 3HP, 230/460V
17	P7194	Motor Pulley
	P3273	1-1/8" Bore Bushing
18	P3218	Blower Pulley
19	P7187	V-Belt

MXT7000 PARTS LIST (HORIZONTAL CONFIGURATION):

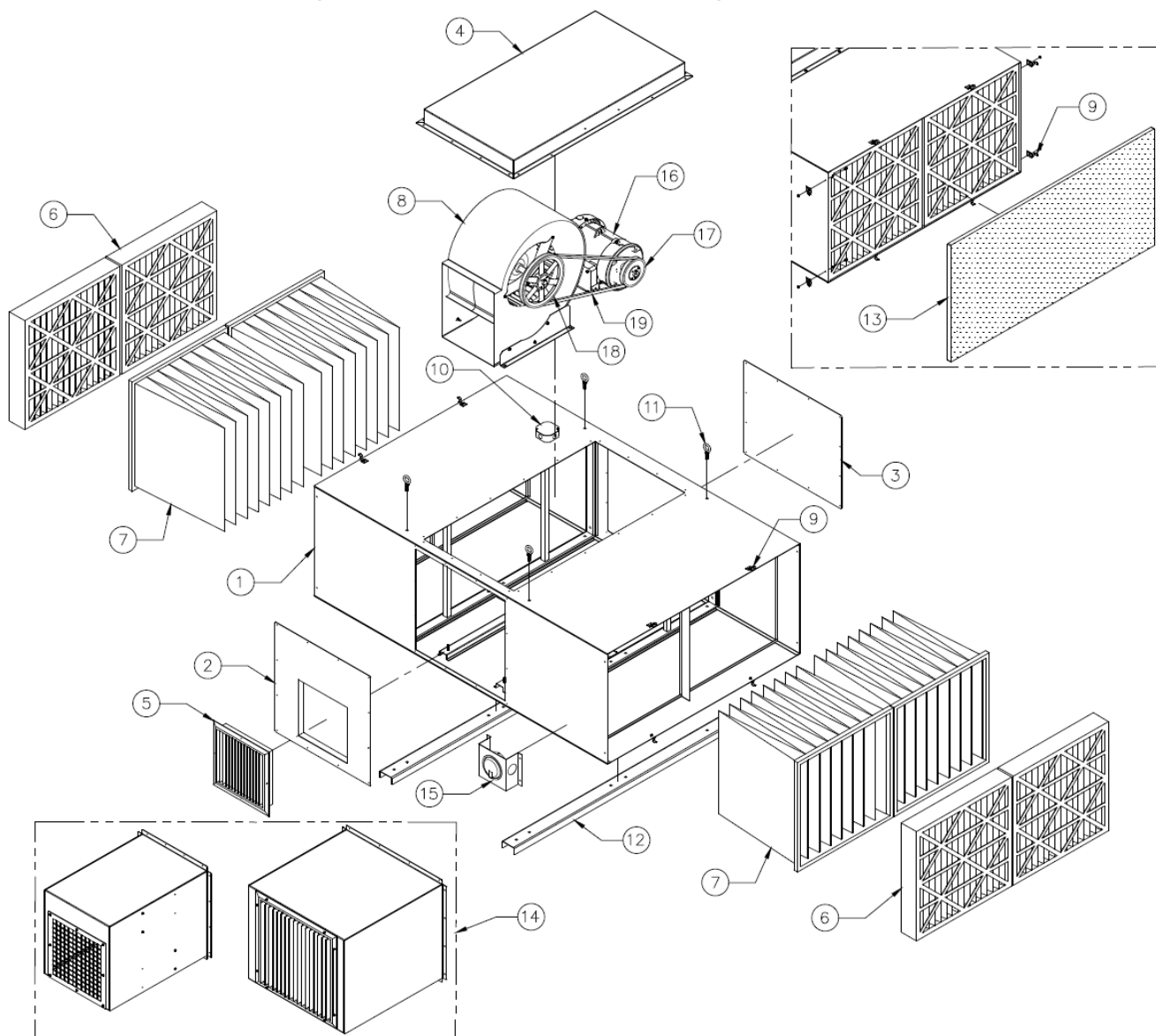

FIG. 19

ITEM	PART NO.	DESCRIPTION	ITEM	PART NO.	DESCRIPTION
1	30651-04	Horizontal Cabinet Weldment	11*	P2437	Eyebolts
2	30655-03	Exhaust Panel	12*	30658-02	C-Channel Mount
3	30656-02	Access Panel	13*	30667-02	Scrim Pre-Filter
4	30681-01	Access Panel	14*	30672-02	MXT7 Silencer Assembly NL
5	P1420	Grille		30672-03	MXT7 Silencer Assembly L
6	P1411	Pleated Pre-Filter	15*	38294-01	Magnehelic Mount Bracket
7	P1440	55% Bag Filter		P2250	0-5" Magnehelic Gauge
	P1441	95% Bag Filter	MXT7000 Drive Package		
8	P7195	Blower	16	P3253	Motor, 5HP, 230/460V
	38080-01	Blower Leg Left	17	P7194	Motor Pulley
	38080-02	Blower Leg Right		P3273	1-1/8" Bore Bushing
9	P335	Latch	18	P7196	Blower Pulley
10	P7182	Junction Box		P3272	1" Bore Bushing
	P7183	Junction Box Cover	19	P7197	V-Belt

*Optional

MXT7000 PARTS LIST (VERTICAL CONFIGURATION):

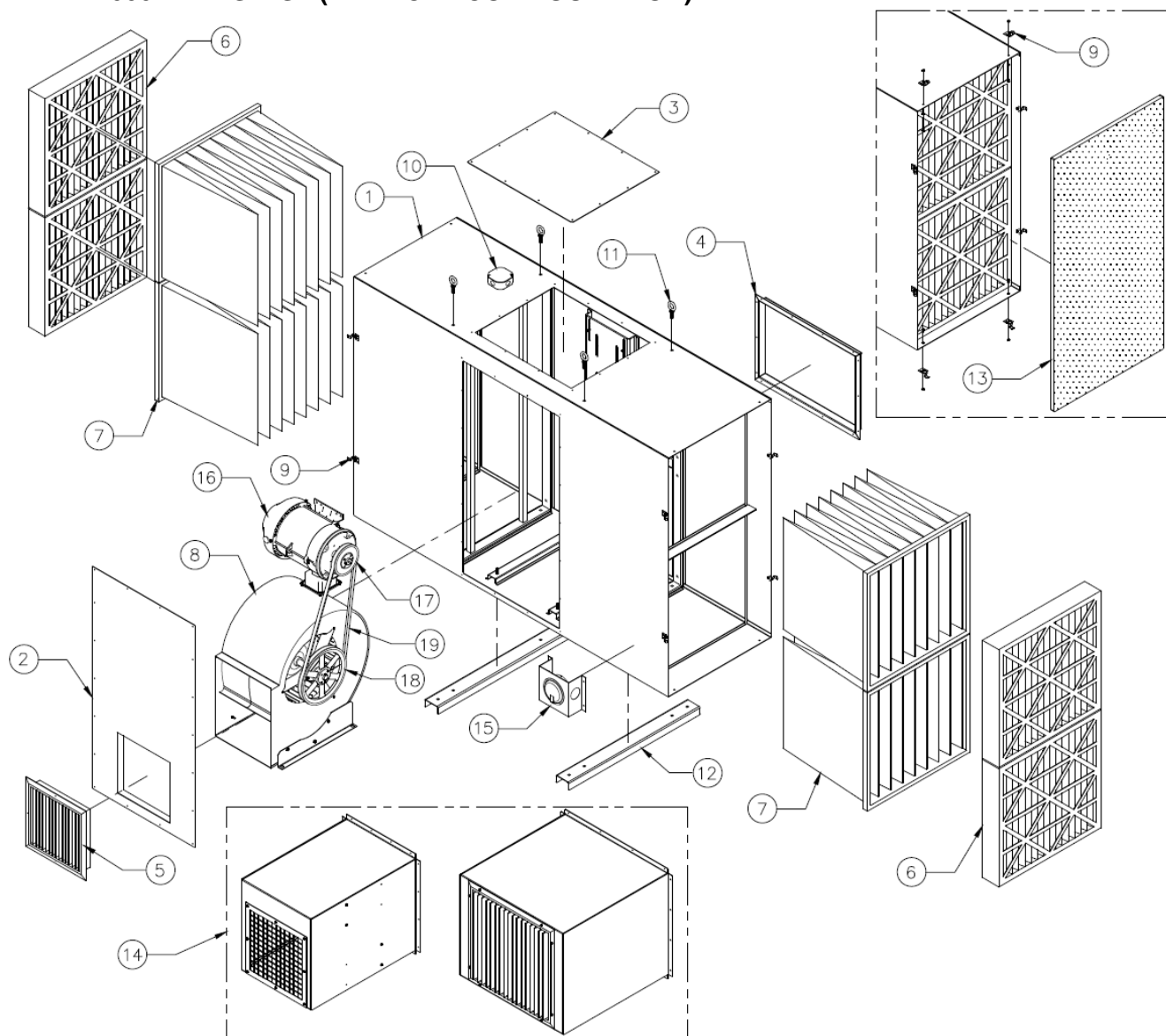

FIG. 20

ITEM	PART NO.	DESCRIPTION	ITEM	PART NO.	DESCRIPTION
1	30651-05	Horizontal Cabinet Weldment	11*	P2437	Eyebolts
2	30655-04	Exhaust Panel	12*	30658-01	C-Channel Mount
3	30656-02	Access Panel	13*	30667-02	Scrim Pre-Filter
4	30681-02	Access Panel	14*	30672-02	MXT7 Silencer Assembly NL
5	P1420	Grille		30672-03	MXT7 Silencer Assembly L
6	P1411	Pleated Pre-Filter	15*	38294-01	Magnehelic Mount Bracket
7	P1440	55% Bag Filter		P2250	0-5" Magnehelic Gauge
	P1441	95% Bag Filter	MXT7000 Drive Package		
8	P7195	Blower	16	P3253	Motor, 5HP, 230/460V
	38080-01	Blower Leg Left	17	P7194	Motor Pulley
	38080-02	Blower Leg Right		P3273	1-1/8" Bore Bushing
9	P335	Latch	18	P7196	Blower Pulley
10	P7182	Junction Box		P3272	1" Bore Bushing
	P7183	Junction Box Cover	19	P7198	V-Belt

*Optional

