



TM500

Installation and Operation Manual



This manual contains specific cautionary statements relative to worker safety. Read this manual thoroughly and follow as directed. It is impossible to list all of the hazards of dust control equipment. It is important that use of the equipment be discussed with a Micro-Air Representative. Persons involved with the equipment or systems should be instructed how to operate in a safe manner.

WARNINGS:

Installation can cause exposure to live components. Disconnect electrical power before proceeding with installation. Proper Lock Out / Tag Out procedures should be used.



All electrical work must be done by a qualified electrician according to local, state and national codes.



Improper installation or operation of this equipment can cause damage to equipment and / or injury to personnel. The installation / operation manual must be read and followed in its entirety.

TM500 SPECIFICATIONS:

Motor:	3/4 HP, 3450 RPM, 1 Phase, TEFC
Input Voltage:	120VAC, 1 Phase, 60 Hz
Max Current:	9.6 Amps
Blower:	Direct Drive
External Arm:	4" dia. x 5' long Source Capture Arm 6" dia. x 7' long Flex Duct w/ Magnetic Hood
Dimensions:	39" H x 16" W x 16" L
Weight	148 lbs. w/ 4" Arm 138 lbs. w/ 6" Flex Hose

PRE-OPERATING INSTRUCTIONS:

1. Inspect the unit for any visible damage that may have occurred during shipment. Report any damage to the delivery carrier.
2. Remove the shipping crate, shipping straps and plastic wrap from unit.
3. Remove the unit from the shipping skid and set on a level surface.
4. Remove the attachment option from the shipping carton.
5. If equipped, install the arm assembly onto the base of the unit (Fig. 1).
6. If equipped, install the hose assembly onto the collar on the base of the unit (Fig. 2).

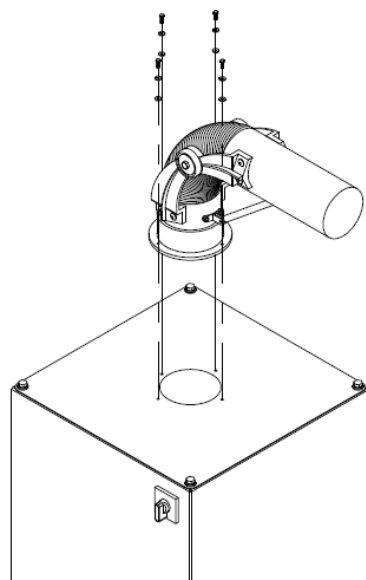

FIG. 1

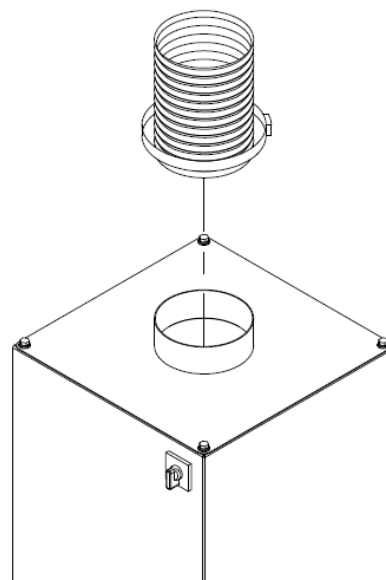

FIG. 2

OPERATING INSTRUCTIONS:

1. Choose a suitable, level place near the workstation and position the unit so that the hose/arm assembly will be placed near the source of pollution being generated.
2. Grasp the hood by the handle ring and position within 18" of the source of pollution.
3. Plug the power cord into an outlet of the appropriate voltage and phase.
4. Turn the power switch on.
5. Adjust the hood to capture the maximum amount of contaminants. Periodically adjust the position of the hood to keep it in maximum capture range.

CHANGING FILTERS:

CAUTION: Always make sure that the unit is turned off before changing filters or servicing the unit. NEVER run the unit with the access door open or panels removed.

1. Turn the TM500 off and remove the filter access panel.
2. Remove the old filter.
3. Slide new filter in place.
4. Re-install the filter access panel (Fig. 3).

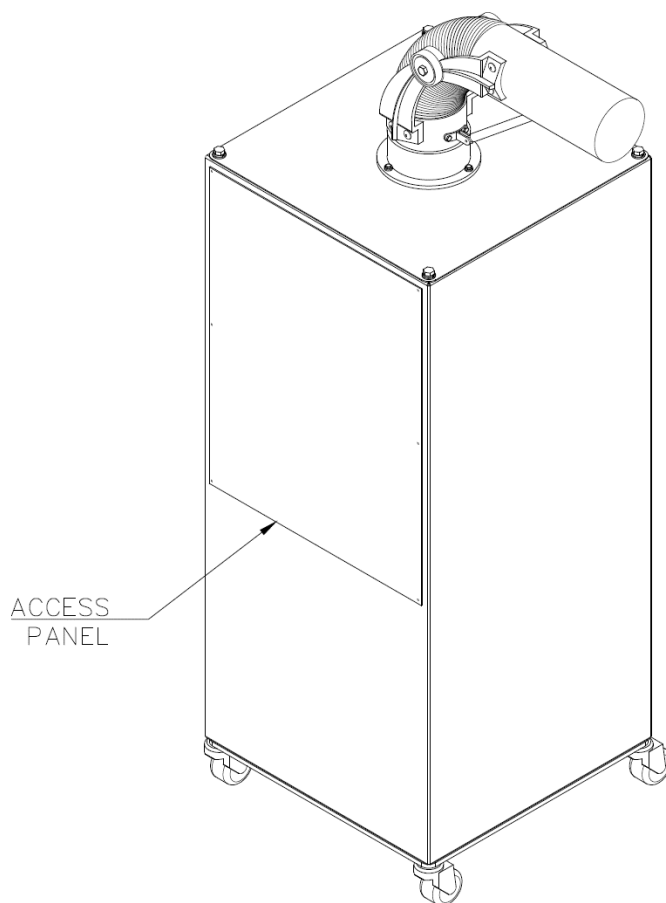

FIG. 3

ELECTRICAL INSTALLATION:

1 PHASE, 120V WIRING DIAGRAM:

⚠ CAUTION: All electrical work must be done by a qualified electrician according to local, state and national codes.

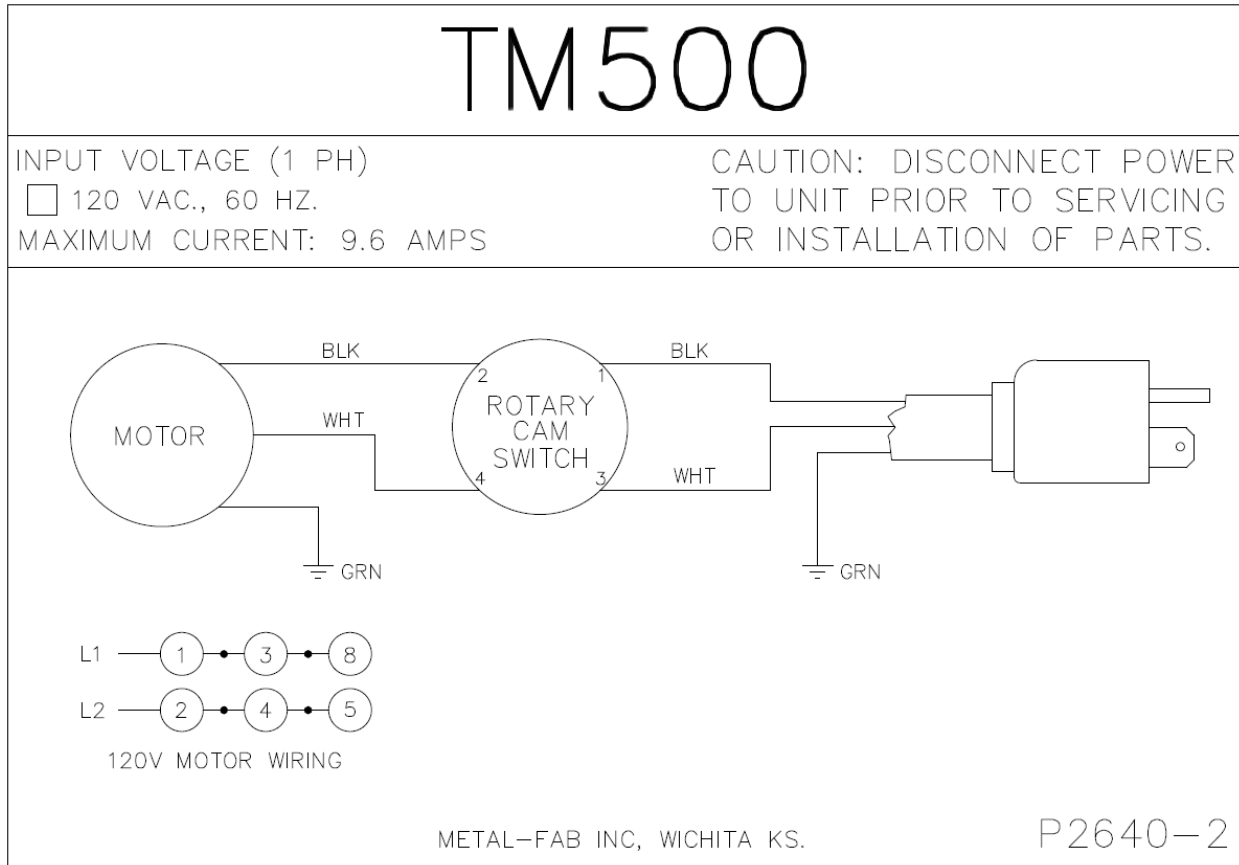

FIG. 4

GENERAL MAINTENANCE:

1. Check the blower bearings for unusual wear and the blower wheel for debris and dirt. Clean when necessary.
2. Periodically inspect hardware for loose nuts and bolts on access panel and internal components. Tighten if necessary.
3. Check the wiring for loose connections or cracked insulation.
4. No lubrication is required for the motor.
5. Once per month, grease the suction arm base assembly with a bearing grease listed not to react with aluminum.
6. Excessive dirt or oil should be removed periodically.

PARTS LIST – 4” DIAMETER ARM ASSEMBLY:

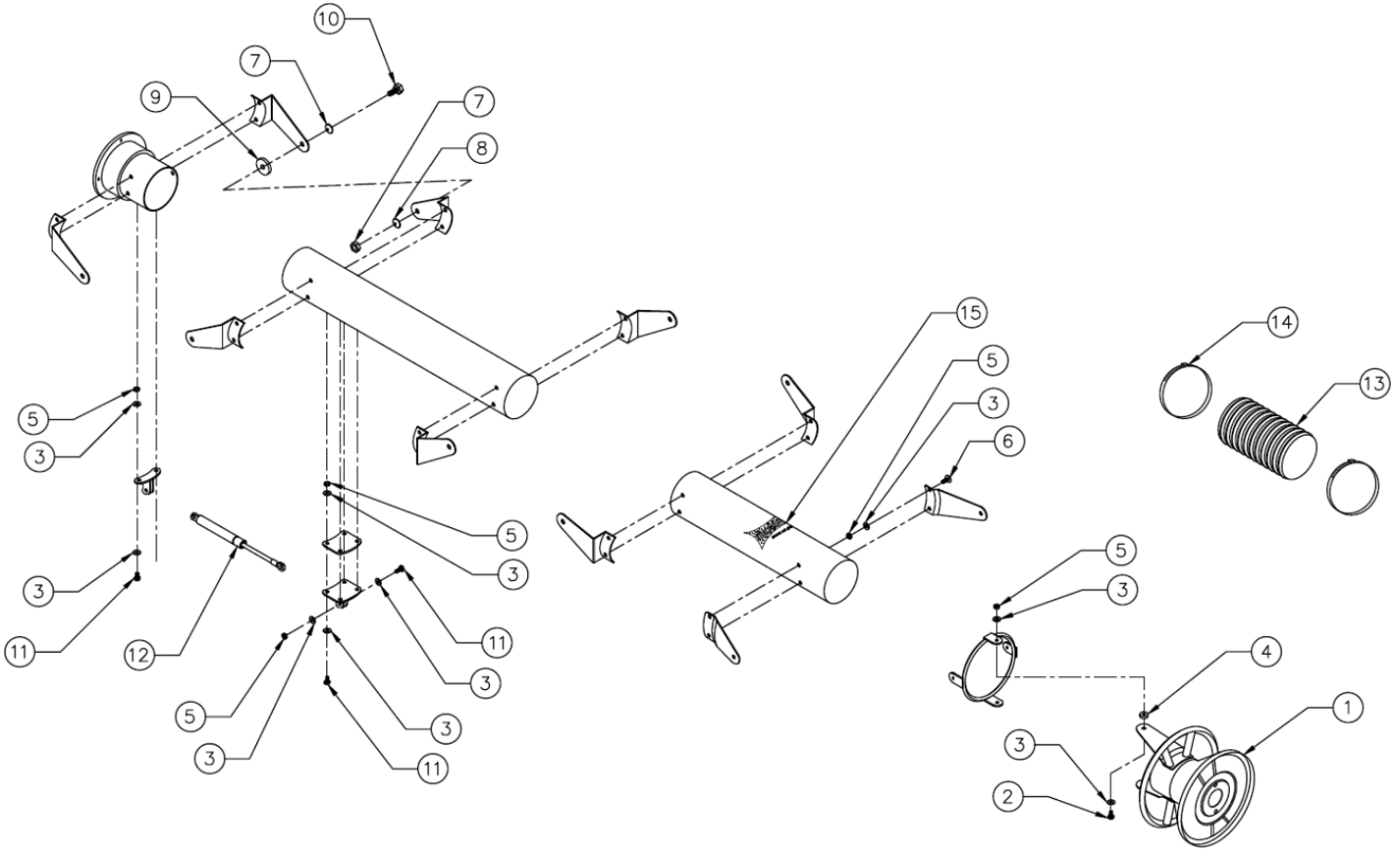
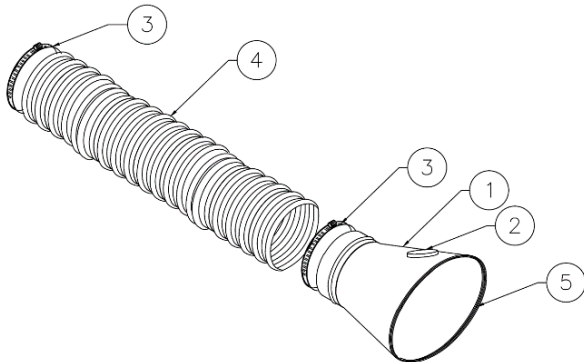

FIG. 5

ITEM	PART NO.	DESCRIPTION	ITEM	PART NO.	DESCRIPTION
1	P2463	4" Hood Assembly	9	P2464	Friction Pad
2	P2483	¼-20 x 1" Hex Head Bolt	10	P2614	5/16-18 x 1" Hex Head Bolt
3	P246	¼ Flat Washer	11	P164	¼-20 x ¾" Hex Head Bolt
4	P2482	Hood Disc Pad	12	P2460	4" Gas Shock
5	P2485	¼-20 Nyloc Hex Nut	13	P2470	4" Dia. Flex Hose
6	P2490	¼-20 Carriage Bolt	14	P2232	Hose Clamp
7	P2484	5/16-18 Hex Nut	15	P2312	Micro Air Decal
8	P2465	Cup Washer			

PARTS LIST – 6” DIAMETER FLEX HOSE ASSEMBLY:



ITEM	PART NO.	DESCRIPTION
1	P2463	4" Hood Assembly
2	P2483	¼-20 x 1" Hex Head Bolt
3	P246	¼ Flat Washer
4	P2482	Hood Disc Pad
5	P2485	¼-20 Nyloc Hex Nut

FIG. 6

PARTS LIST – TM500:

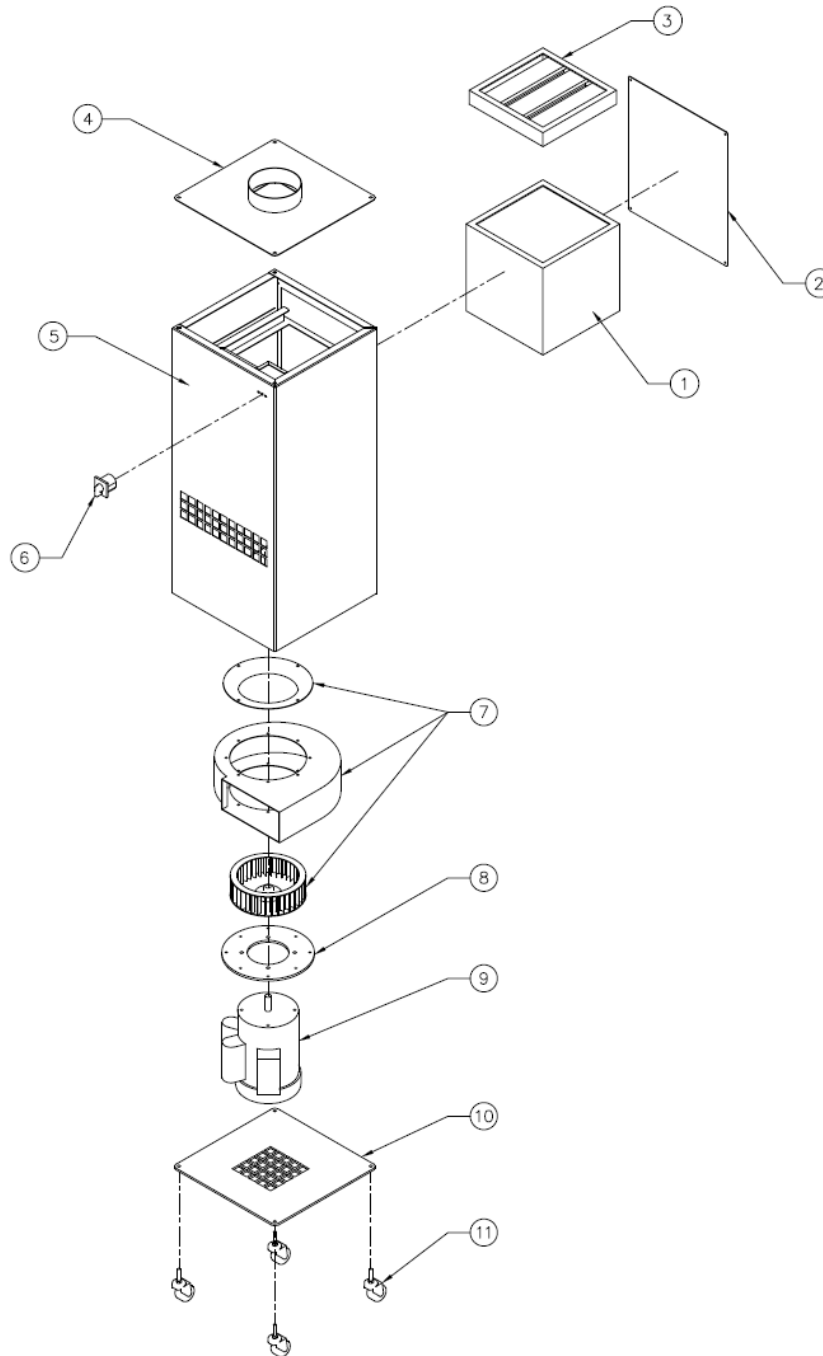

FIG. 7

ITEM	PART NO.	DESCRIPTION	ITEM	PART NO.	DESCRIPTION
1	P2643	95% DOP Filter	7	P3028	Blower Assembly
	P2644	99.97% HEPA Filter	8	38907-01	Motor Mount Plate
2	38908-01	Access Panel	9	P7122	3/4 HP Motor
3	P2645	Baffle Filter	10	38909-01	Bottom Plate
4	38910-01	4" Arm Plate	11	P2642	Caster
	38910-02	6" Flex Hose Plate	N/S	38914-01	4" Arm Assembly
5	38901-01	Cabinet Weld	N/S	38913-01	6" Flex Hood Assembly
6	P7110	On/Off Switch			

