

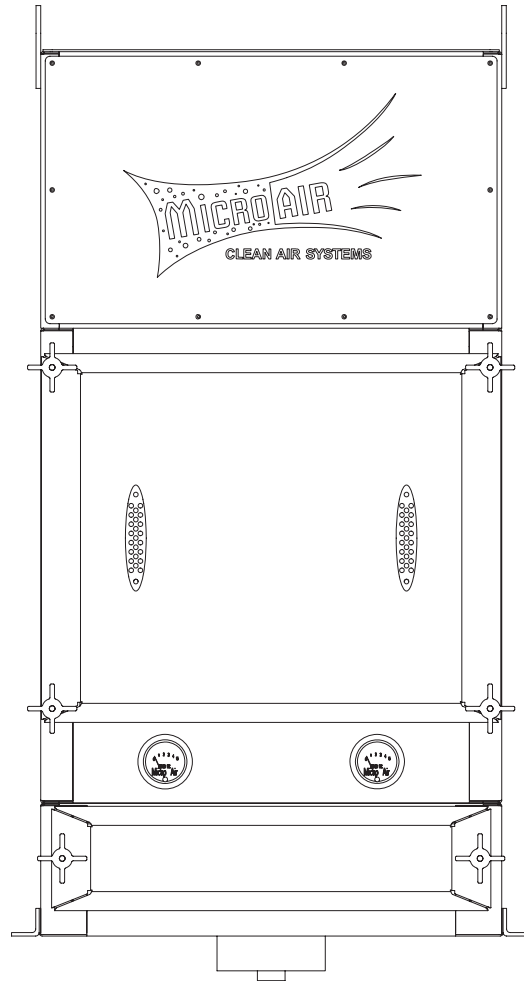

MISTMAX™

MODEL MM800

Installation and Operation Manual



Important:

This manual contains specific cautionary statements relative to worker safety. Read this manual thoroughly and follow as directed. It is impossible to list all the hazards of oil mist control equipment. All persons involved with the equipment or systems should be instructed how to operate in a safe manner.

MODEL MM800 SPECIFICATIONS

INPUT VOLTAGE:

208-230V / 460V 60Hz 3 Phase

MAXIMUM CURRENT:

2HP 208V: 5.8 Amps
230V: 5.6 Amps
460V: 2.8 Amps

MOTOR:

2HP 3 Phase 3450 RPM TEFC

OVERALL DIMENSIONS:

Base Unit: 54" H x 25" W x 25" D

FILTER AREA:

51 Sq. Feet

PACKAGE CONTENTS:

1 Ea. MM800
1 Ea. Owners Manual
1 Ea. Motor Control Box

INSPECTION:

The Micro Air oil mist unit is shipped on one skid. This skid should be inspected for any visible damage that may have occurred during shipment. Note any damage on the packing slip.

1. Un-crate the air cleaner. Use caution not to damage the paint while dismantling the crate.
2. Remove any options ordered from the skid.
3. Using a forklift and lifting chains or straps, lift the air cleaner off the skid. Note: Do not set the air cleaner on the inlet collar, this may damage the collar.

⚠ CAUTION: The Weight of the unit is not evenly dispersed and the unit could tip over.

HANGING MOUNT INSTRUCTIONS:

Determine the location where the air cleaner is to be installed. Be sure to allow sufficient room around the air cleaner to service the filters, and allow for exhaust air.

1. Carefully place the air cleaner into it's location.
2. Use chain or all-thread to attach the air cleaner at the provided hanging brackets to structural supports (FIG 1).

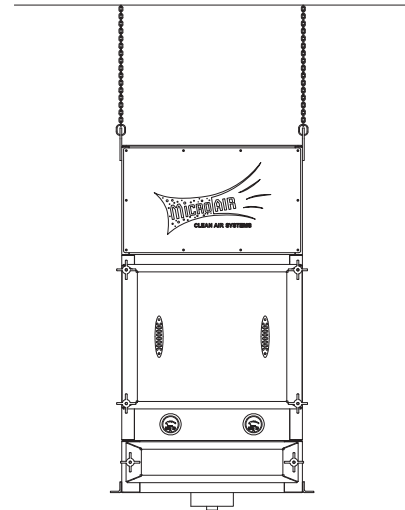

Fig. 1

DIRECT MOUNT INSTRUCTIONS:

Determine the location where the air cleaner is to be installed. Be sure to allow sufficient room around the air cleaner to service the filters, and allow for exhaust air.

1. Cut holes in the top of the machine that the air cleaner is to be mounted to.
2. Bolt the air cleaner to the machine in it's final location using the provided holes in the flanges of the air cleaner (FIG 2).

STAND MOUNT INSTRUCTIONS:

Determine the location where the air cleaner is to be installed. Be sure to allow sufficient room around the air cleaner to service the filters, and allow for exhaust air.

1. Bolt the air cleaner to the stand and the stand to the floor in it's final location using the provided holes in the flanges of the air cleaner and stand (FIG 2).

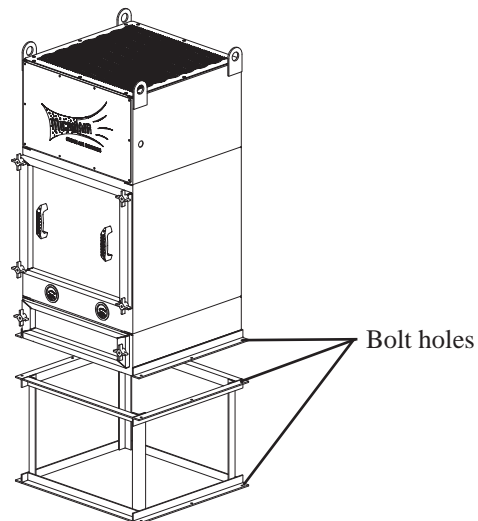

Fig. 2

ELECTRICAL INSTALLATION:

⚠ All electrical work must be done by a qualified electrician according to local, state and national codes.

⚠ CAUTION: Installation can cause exposure to live components. Disconnect electrical power before proceeding with installation. Proper Lock Out / Tag Out procedures should be used.

1. Micro Air recommends that a fusible disconnect be installed upstream from the Motor Control Box.
2. Determine the location for the Motor Control Box.
3. Make electrical connections as shown in the wiring diagram to the wires protruding from the conduit on the side of the air cleaner.
4. Check blower for proper rotation direction (FIG 3). If the blower rotates backwards, interchange two of the motor supply connections (L1 and L2).
5. Check current draw of motor. Do not exceed specified amperage.

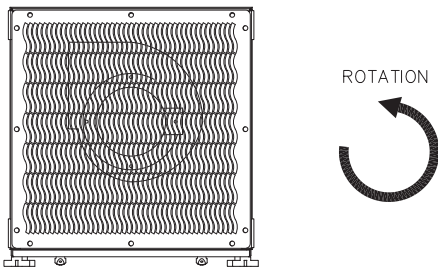

Fig. 3

OPTIONAL HEPA AFTER FILTER:

1. Remove the bolts and washers from the exhaust grille.
2. Place Hepa filter and Hepa filter enclosure on top of the exhaust grille.
3. Align the holes of the Hepa filter enclosure with those on the blower cabinet.
4. Insert bolts and washers and tighten until secure.

OIL DRAINAGE:

Note: Should captured oil be disposed of, make sure to follow local codes.

Provision for draining oil from the unit is provided for by a 1" N.P.T. pipe coupling on the bottom of the air cleaner. Drainage can be piped directly back to the machine

producing it, to a central collection system or collected in a bucket placed under the air cleaner. In all cases except for directly back into the machine that produced it a shut-off valve or drain trap is required to prevent air bypass through the drain opening. One of the drain systems shown in (FIG 4) should be used. Drain connections and lines are not provided.

Note: If a shut off valve is installed in the drain system, the unit must be emptied regularly to prevent oil from overflowing into the intake duct.

⚠ CAUTION: Any duct used to connect the mist collector to the machine should slope towards the machine in order to prevent oil build up in the duct work. If this is not possible a method of draining oil from the ductwork should be provided.

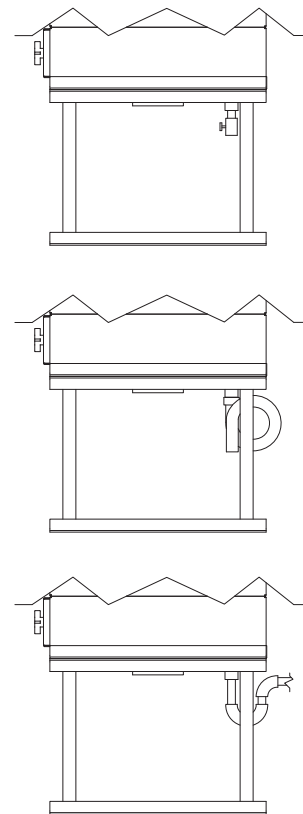

Fig. 4

OPERATION:

1. To start unit, turn the switch to the position labeled ON.
To stop the unit, turn the switch to the position labeled OFF.

GENERAL MAINTENANCE:

1. No lubrication is required for the motor because it is a permanent pre-lube design. Excessive dirt / oil should be periodically removed.
2. Make sure oil is draining easily through drain pipe, and that no oil has built up in the intake duct.

CHANGING FILTERS:

⚠ CAUTION: Always make sure that the unit is turned off before changing filters or servicing the unit.

1. The MM800 is equipped with dual filter gauges (0-5" for pre-filter and 0-10" for main filters). The pre-filter should be removed, cleaned and inspected when the gauge labeled pre-filter reads 2" W.C. The main filters should be removed and replaced when the gauge labeled main filter reads between 6" W.C. and 8" W.C. (depending on desired airflow).
2. The pre-filters should be cleaned in a detergent solution to remove dirt and oil residue.
3. Rinse the pre-filters thoroughly with water, shake dry and replace in the unit.
4. Start the unit. The filter gauge should read below 2" for the pre-filters or below 6" for the main filters.

MM800

INPUT VOLTAGE (3 PH)

- 208-230 VAC.
- 460 VAC.
- OTHER: _____ VAC.

FREQUENCY

- 60 HZ.

MAXIMUM CURRENT

_____ AMPS

CAUTION: DISCONNECT POWER TO UNIT PRIOR TO SERVICING OR INSTALLATION OF PARTS.

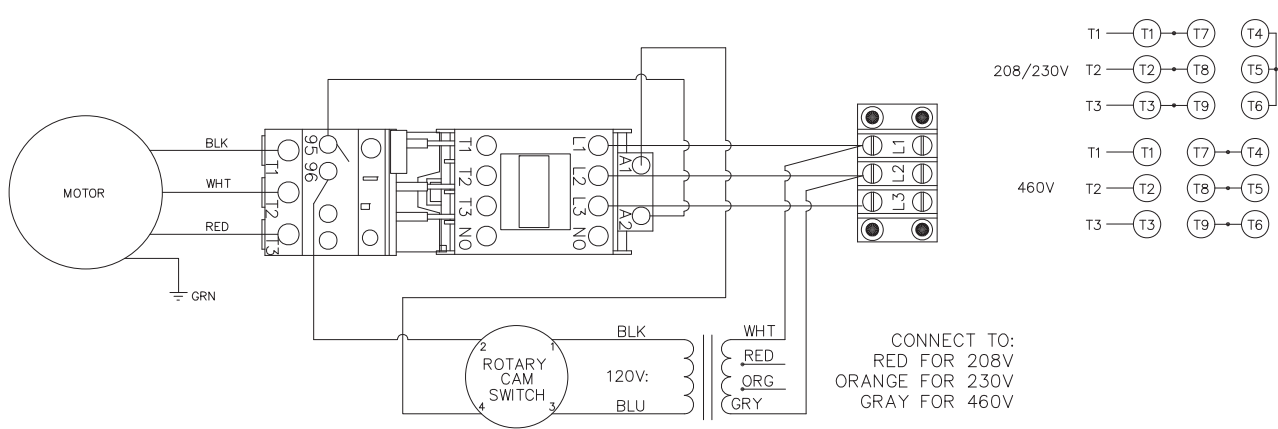

CONNECT TO:
RED FOR 208V
ORANGE FOR 230V
GRAY FOR 460V

METAL-FAB INC, WICHITA KS.

P7329-1

208/230/460 Volt Wiring Diagram

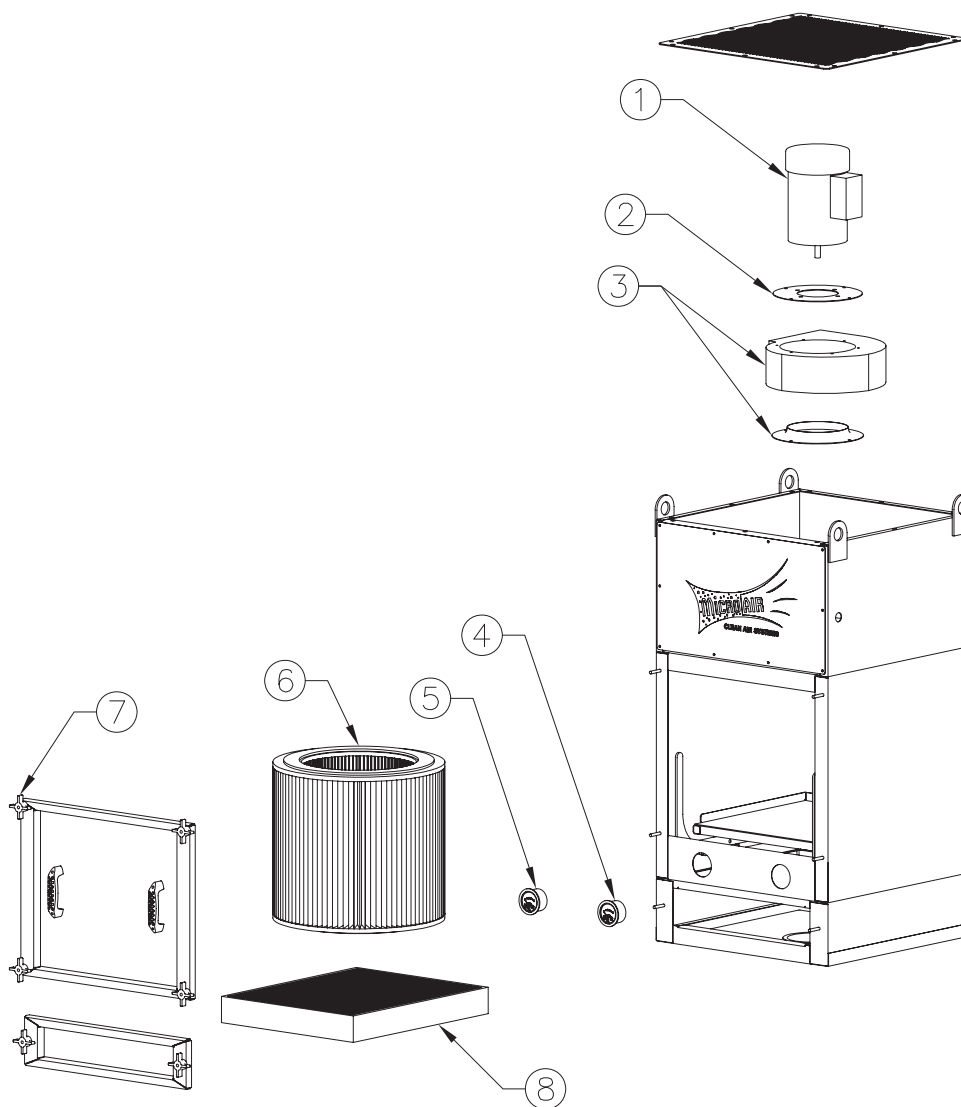

MM800 PARTS LIST

ITEM	PART NO.	DESCRIPTION
①	P2320	2 HP Motor
②	38785-03	Motor Mounting Plate
③	P2302	Blower Wheel, Housing and Inlet Plate
④	P7297	0-10" W.C. Mini-Helic Gauge
⑤	P2221	0-5" W.C. Mini-Helic Gauge
⑥	P7291	Cartridge Filter
⑦	P3649	4-Prong Knob
⑧	P7292/P1828 & P7309	Mist-X Pre-Filter / Baffle & Mesh Pre-Filter
NS	P7308	99.97% Hepa After Filter