



**BREATHE EASY...Solutions for Clean, Safe Air**

## MISTMAX® MM3600 Specifications and Technical Data

### TYPICAL APPLICATIONS: Source Capture of:

- OIL MIST, SMOKE FROM HIGH SPEED MACHINING CENTERS
- HIGH VOLUME MIST APPLICATIONS OIL OR WATER SOLUBLE, SMOKE



### STANDARD FEATURES:

- 3,600 CFM ACTUAL
- EXTENDED FILTER LIFE
- MISTMAX® PATENTED FILTER TECHNOLOGY COMPETES WITH EUROPEAN TECHNOLOGIES
- 99.98% EFFICIENT WITHOUT ADDITIONAL HEPA FILTERS
- DUAL GAUGES TRACK STATIC PRESSURE ON BOTH THE PRE-FILTER AND PRIMARY FILTER
- FRONT LOAD, EASY FILTER ACCESS
- HIGH CAPACITY DIRECT DRIVE BLOWER
- START / STOP SWITCH STD.

- 2 EA. 14" DIA. INLET COLLARS, LOCATED LEFT, AND RIGHT WITH 2 EA. 14" DIA CAPS
- CAM LOCK POSITIVE FILTER SEAL SYSTEM ENSURES NO BY-PASS

### OPTIONS:

- HEPA AFTER-FILTER
- BAFFLE / MESH PRE-FILTER COMBINATION
- MIST-X (CHEVRON) PRE-FILTER
- FLOOR STAND

### HOW IT WORKS:

The future of oil mist filtration is here with Micro Air's newest development, the patented, extended life, multi-layered **MISTMAX™** oil mist filter. This new technology incorporates Brownian diffusion techniques (smaller particles randomly combine to form larger, more easily removed particles) along with traditional impingement technologies to



provide the newest technological advancement in mist filtration. Depending on the application **MIST-MAX™** filters will provide extended filter life in applications such as high-speed machining centers, heat treating, cold drawing, gear cutting etc., operations once deemed too tough for traditional methods of mist collection. Mist laden air flows through the inlet or inlets into the bottom plenum. The air then turns 90 degrees and goes upward through the exclusive Mist-X pre-separation filter where most of the oil is removed. Finally, the air goes

through the four 99.98% efficient **MISTMAX™** filters. These special filters remove any remaining mist and smoke. Clean air is then discharged at the top of the unit. Oil, removed from the airstream, drains out the bottom of the plenum.



**MM3600—  
Ducted to Machining Process**



# MM3600

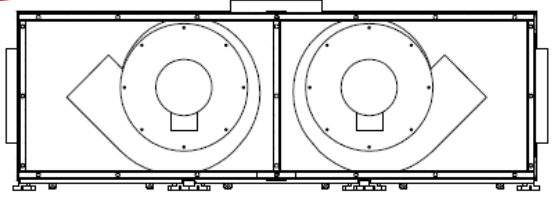
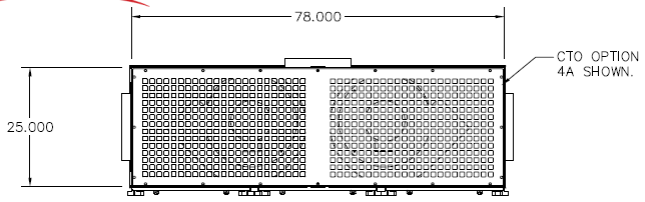

SECTION B-B

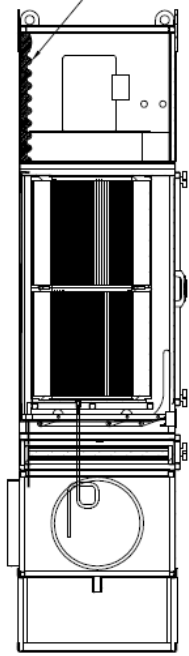
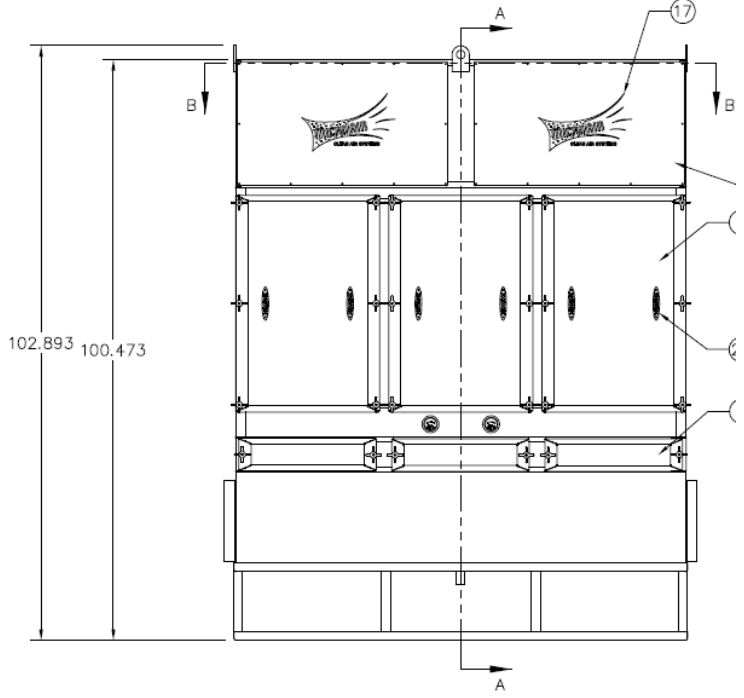

SECTION A-A

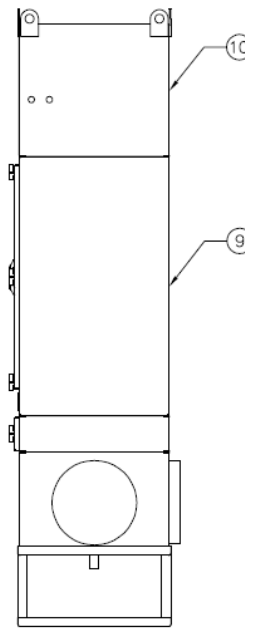

## MM3600

### MM3600 SPECIFICATIONS:

<p><b>OVERALL DIMENSIONS:</b> 103" H X 78" W X 25" D WITH FLOOR STAND</p> <p><b>WEIGHT:</b> *1,700 LBS ACTUAL WEIGHT *1,800 LBS SHIPPING WEIGHT *WEIGHT VARIES DEPENDING UPON OPTIONS SELECTED</p> <p><b>CABINET:</b> HEAVY DUTY 14 GA. WELDED GALFANEAL STEEL W/EXTERIOR SURFACES GROUND SMOOTH</p> <p><b>FINISH:</b> INDUSTRIAL GRADE TEXTURED BAKED CRIMSON RED ENAMEL PAINT INSIDE AND OUT</p> <p><b>FILTER ACCESS:</b> FRONT LOAD THROUGH DOOR FOR EASY ACCESS</p> <p><b>MOTOR:</b> DUAL 7.5 HP, TEFC, 208 / 230 OR 460V, 60 HZ, THREE PHASE, SINGLE SPEED</p> <p><b>BLOWER:</b> DUAL DIRECT DRIVE, HIGH STATIC, BACKWARD INCLINED IMPELLER</p> <p><b>AIR VOLUME:</b> 3,600 CFM ACTUAL</p> <p><b>PREFILTER:</b> HIGH-EFFICIENCY MIST-X (CHEVRON) PRE-FILTERS</p>	<p><b>STANDARD PRIMARY FILTER:</b> EXTENDED LIFE, 99.98% HIGH EFFICIENCY, MULTI-LAYER, MISTMAX® CARTRIDGE STYLE FILTERS</p> <p><b>FILTER CHANGE INDICATOR:</b> DUAL MINIHELIC GAUGES, ONE EA. ON PRE-FILTER AND PRIMARY FILTER</p> <p><b>CONTROLS:</b> 208-230/460V, 3 PHASE, PREWIRED TO NEMA 4 START /STOP SWITCH</p> <p><b>INLET / EXHAUST:</b> INLET—2 EA. 14" DIA. COLLARS WITH 2 EA 14" DIA. CAPS EXHAUST - OUT TOP OF UNIT</p> <p><b>MAX CURRENT</b> 208—230V / 460V—37.8 / 18.9 AMP</p> <p><b>NOISE LEVELS:</b> 82 dBA @ 5'</p> <p><b>OIL DRAIN</b> (3) EA 1" NPT PIPE COUPLING (FEMALE)</p> <p><b>MOUNTING:</b> 12" H. FLOOR STAND</p>
---	---

SPECIFICATIONS SUBJECT TO CHANGE WITHOUT NOTICE