



BREATHE EASY...Solutions for Clean, Safe Air

MA4210

Specifications and Technical Data

TYPICAL APPLICATIONS:

SOURCE CAPTURE OF:

- WELDING SMOKE AND FUMES
- GRINDING DUST
- SOLVENT ODOR CONTROL
- OTHER DUSTS / FUMES / MISTS
- ODOR CONTROL



STANDARD FEATURES:

- EXTERNALLY SUPPORTED ARM / ARMS
- SIDE LOAD, EASY FILTER ACCESS
- FULL RANGE OF OPTIONS
- CAM-LOCK POSITIVE FILTER SEALING
- ROTATING ARM AND CAPTURE HOOD
- POSITIVE SEALING CABINET AND DOOR
- HEAVY DUTY BLOWER

OPTIONS:

- FILTER CHANGE LIGHT OR MAGNEHELIC GAUGE
- 24" x 24" x 12" REFILLABLE MODULES WHICH WILL HOLD UP TO 40 LBS OF CARBON EACH (80 LBS WITH DUAL MODULES)
- 95% OR 99.97% DOP HEPA AFTER-FILTER
- BIG WHEEL KIT
- 6" AND 8" DIA. ARMS
- LIGHT KIT FOR HOOD

HOW IT WORKS:

Polluted air flows through the pre-filter section, effectively removing the larger particles of the pollutant. Next the air passes through the main filtration system. This portion contains the primary filter media, bag filters, HEPA filters, carbon modules or a combination. This process captures minute particles of airborne impurities and absorbs gases and odors. The discharged air is then pollution free, leaving your facility with Breathe Easy, Clean Safe Air.

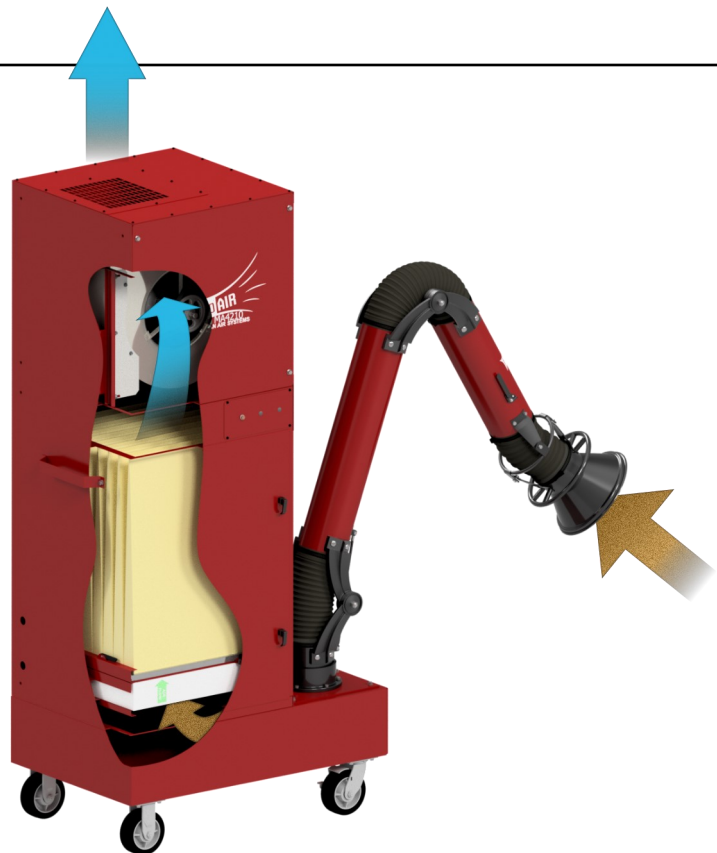



MA4210

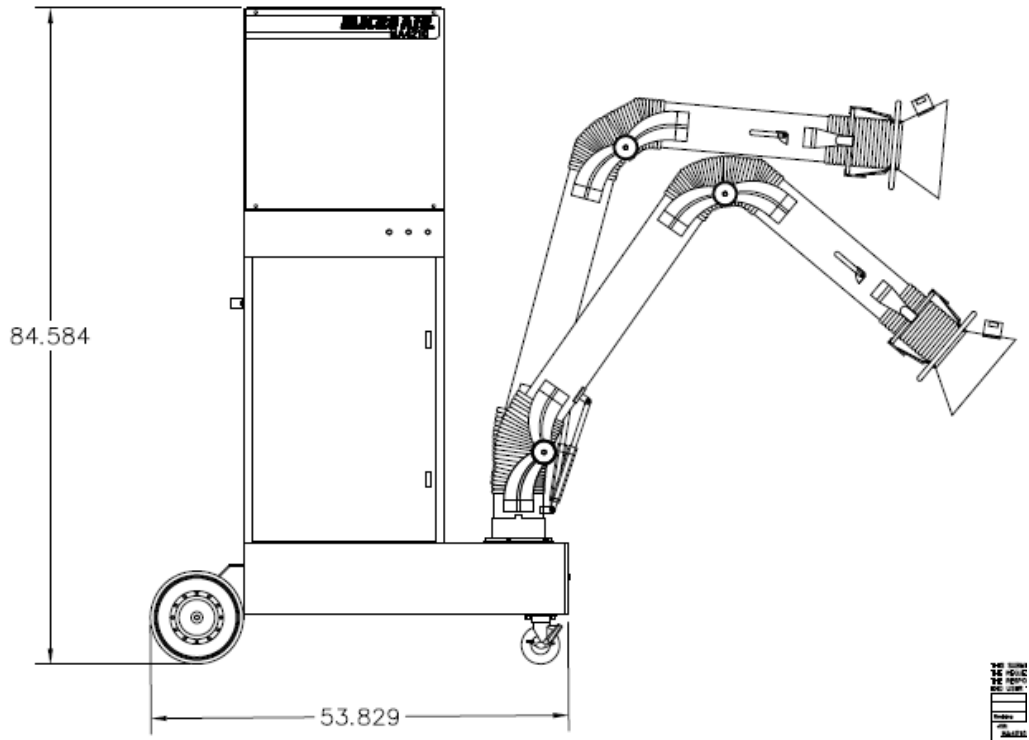

MA4210 EQUIPPED WITH 2 EA. 6" DIA X 9' SOURCE CAPTURE ARMS

MA4210 SPECIFICATIONS:

OVERALL DIMENSIONS:

86" H X 26" W X 41" L

WEIGHT:

- *322 LBS ACTUAL WEIGHT
- *364 LBS SHIPPING WEIGHT
- *WEIGHT VARIES DEPENDING UPON OPTIONS SELECTED

CABINET:

HEAVY DUTY 16 GA. WELDED GALVANEAL STEEL W/EXTERIOR SURFACES GROUND SMOOTH

FINISH:

INDUSTRIAL GRADE TEXTURED BAKED CRIMSON RED ENAMEL PAINT—INSIDE AND OUT

PREFILTER OPTIONS:

- 24" X 24" X 4", 35% EFFICIENCY PLEATED PRE-FILTER WITH 28 SF MEDIA.
- 24" X 24" X 2" PLEATED PRE-FILTER
- 24" X 24" X 2" ALUMINUM MESH PRE-FILTER
- 24" X 24" X 2" BAFFLE IMPINGER

STANDARD PRIMARY FILTER OPTIONS:

- 24" X 24" X 32" 55% BAG FILTER
- 24" X 24" X 32" 95% BAG FILTER
- 24" X 24" X 15" 55% BAG FILTER—USE W/ HEPA OR CARBON MODULE
- 24" X 24" X 15" 95% BAG FILTER—USE W/ HEPA OR CARBON MODULE
- 24" X 24" X 32" 95% OIL MIST BAG FILTER
- 24" X 24" X 15" 95% OIL MIST BAG FILTER—USE W/HEPA OR CARBON
- 24" X 24" X 12" 99.97% DOP HEPA FILTER
- 24" X 24" X 12" REFILLABLE CARBON MODULE—40 LBS CAPACITY EA

FILTER ACCESS:

SIDE LOAD THROUGH HINGED DOOR FOR EASY ACCESS

ARM OPTIONS:

6" AND 8" DIAMETER, 7' OR 9' LENGTHS, DUAL ARM CAPABILITY WITH 6" DIA ARMS, 355 DEGREE ROTATION AT BASE

NOISE LEVEL:

71 dBA @ 6" FROM EXHAUST

INLET / EXHAUST:

INLET AT HOOD OF SOURCE CAPTURE ARM / EXHAUST OUT TOP OF UNIT

MOTOR OPTIONS:

- 1-1/2 HP, 120V, 60HZ, 1-PHASE, TEFC MOTOR
- 3 HP, 230/460V, 60 HZ, 3-PHASE, TEFC MOTOR

BLOWER:

BELT DRIVEN, 12-9 BLOWER

DRIVE SYSTEM:

LOW, MEDIUM, OR HIGH STATIC PULLEY COMBINATIONS ARE AVAILABLE. CONSULT FACTORY

INPUT VOLTAGE OPTIONS:

- 1-1/2 HP — 120V, 60 HZ, 1-PHASE
- 3 HP — 230/460V, 60 HZ, 3-PHASE

MAX CURRENT

- 1-1/2 HP, 120V — 16 AMP
- 3 HP, 230/460V — 8.4 / 4.2 AMP

AIR VOLUME:

800—1600 CFM, DEPENDENT ON OPTIONS SELECTED. CONSULT FACTORY

FILTER CHANGE INDICATOR OPTIONS:

- 0-5" MAGNEHELIC GAUGE
- FILTER CHANGE LIGHT

SPECIFICATIONS SUBJECT TO CHANGE WITHOUT NOTICE