



**BREATHE EASY...Solutions for Clean, Safe Air**

# MICRO AIR TM1000 Specifications and Technical Data

## TYPICAL APPLICATIONS: Source Capture of:

- WELD SMOKE AND FUMES
- GRINDING DUST
- PARTICULATE FROM BUFFING/POLISHING
- DRY PARTICULATE



### STANDARD FEATURES:

- DUAL SELF-CLEANING CARTRIDGES
- HIGH CAPACITY CLEANING
- COMPACT DESIGN
- WIDE RANGE OF FILTER OPTIONS
- LOW POWER REQUIREMENTS  
120V, SINGLE PHASE
- IMPROVED SOURCE CAPTURE ARM—  
DESIGNED FOR EASE OF MOVEMENT, LESS  
RESTRICTION AND POWERFUL COLLECTION  
AT THE SOURCE
- ROTO-PULSE® CARTRIDGE CLEANING  
SYSTEM

### OPTIONS:

- BROAD CHOICE OF ATTACHMENTS TO ADAPT  
TO ANY APPLICATION OR PROCESS
- 2 HP, 208/230 V, 3 PHASE MOTOR
- 2 HP, 460V, 3 PHASE MOTOR
- AUTO-PULSE CARTRIDGE CLEANING
- 99.97% HEPA AFTERFILTER
- REFILLABLE CHARCOAL MODUL
- MULTIPLE ARM DIAMETER / LENGTH COMBI-  
NATIONS
- BIG WHEEL KIT (REQUIRED WITH 8" x 9' ARM  
OPTION)

### HOW IT WORKS:

Contaminated Air is pulled into the hood on the source capture arm, then, travels down through the cartridge section, where the contaminant is filtered out and dropped into the dust drawer at the bottom of the unit. Clean, safe air is exhausted out the bottom of the unit. Cartridge cleaning is accomplished with Micro Air's, proprietary Roto-Pulse® cleaning system where air is pulsed into a specially designed stainless steel rotating tube, engineered with pre-drilled holes. As the air enters this tube the force of the pulse causes the tube to rotate inside the cartridge. While spinning, air exits the pre-drilled holes, resulting in air dispersement over the entire surface of the cartridge, providing for a more efficient cartridge cleaning cycle.

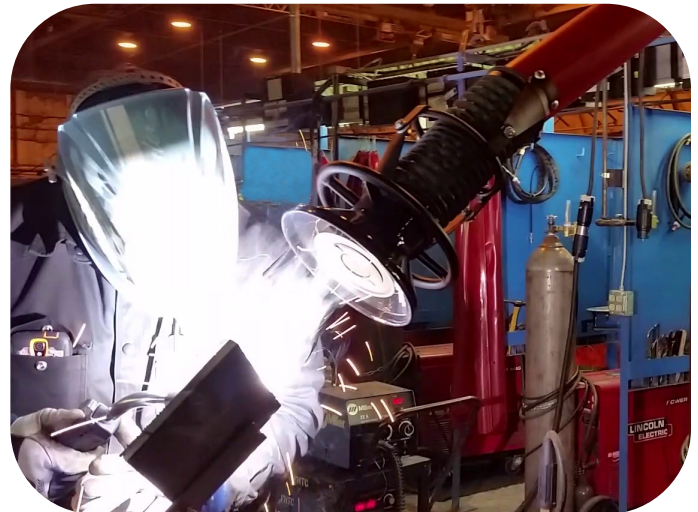

**TM1000  
Weld Smoke and Fume Collection**



# TM1000

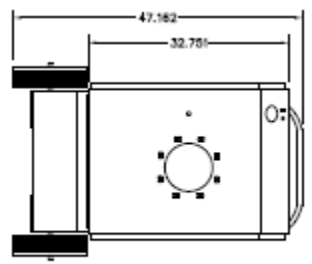
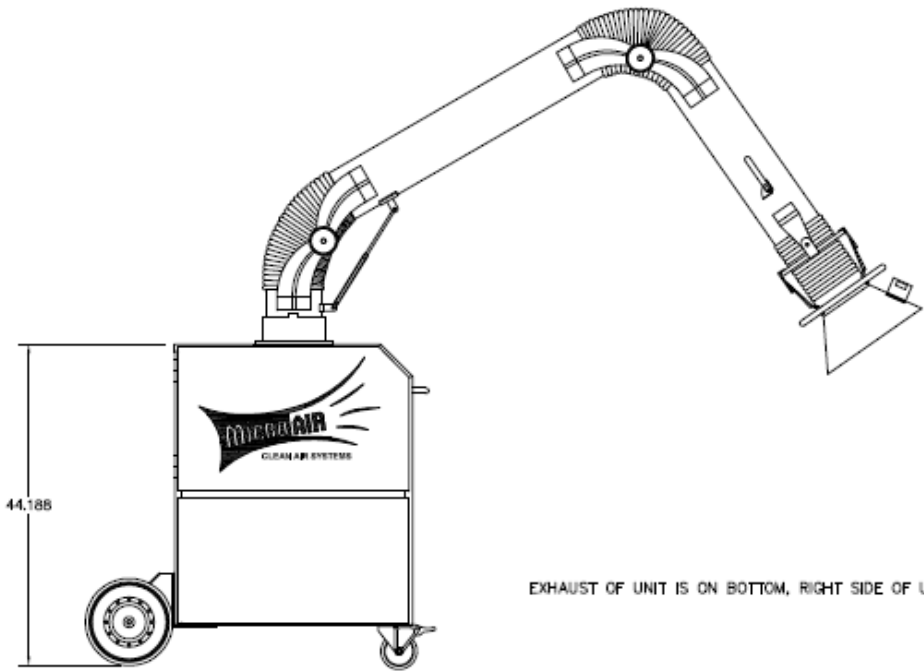

NOTE: ARM AND BASE REMOVED FOR CLARITY.

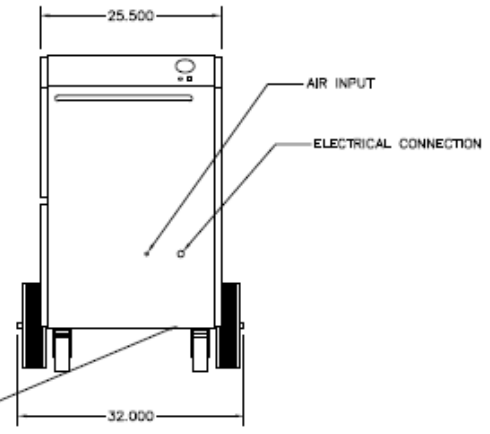

EXHAUST OF UNIT IS ON BOTTOM, RIGHT SIDE OF UNIT.

NOTE: ARM AND BASE REMOVED FOR CLARITY.

## TM1000

### TM1000SPECIFICATIONS:

**OVERALL DIMENSIONS:**

23.5" W X 34.5" L X 44.5" H

**BASE WEIGHT:**

- \*300LBS ACTUAL WEIGHT
- \*350 LBS SHIPPING WEIGHT
- \*WEIGHT VARIES DEPENDING UPON OPTIONS SELECTED

**CABINET:**

HEAVY DUTY 14 GA. WELDED GALFANEAL STEEL W/EXTERIOR SURFACES GROUND SMOOTH

**FINISH:**

INDUSTRIAL GRADE TEXTURED BAKED CRIMSON RED ENAMEL PAINT INSIDE AND OUT

**FILTER ACCESS:**

SIDE LOAD THROUGH DOOR FOR EASY ACCESS

**MOTOR:**

HIGH PRESSURE, DIRECT DRIVE BLOWER, 3450 RPM

**BLOWER:**

DUAL DIRECT DRIVE, HIGH STATIC, BACKWARD INCLINED IMPELLER

**AIR VOLUME:**

1,000 CFM ACTUAL

**STANDARD PRIMARY FILTER:**

TWO EA. HIGH EFFICIENCY 80/20 CARTRIDGES, 142 SF MEDIA EA. MULTIPLE OPTIONS AVAILABLE, CONSULT FACTORY

**CARTRIDGE FILTER CLEANING:**

MANUALLY ACTIVATED, SELF-CLEANING ROTO-PULSE® SYSTEM - REQUIRES 80 PSI AIR CONNECTION

**FILTER CHANGE INDICATER:**

MINIHELIC PRESSURE GAUGE FOR FILTER CLEANING NOTIFICATION

**CASTERS:**

5" INDUSTRIAL GRADE—TWO SWIVEL AN TWO FIXED FOR EASE OF MOBILITY, (NOTE: BIG WHEEL KIT REQUIRED FOR USE WITH 9' ARM)

**CONTROLS:**

FRONT, CABINET MOUNTED ON/OFF SWITCH, MANUAL PULSE BUTTON FOR CARTRIDGE CLEANING

**INLET / EXHAUST:**

- INLET—HOOD ON SOURCE CAPTURE ARM
- EXHAUST - OUT BOTTOM OF UNIT

**MAX CURRENT**

120V—14.4 AMP

**NOISE LEVELS:**

- 76 dBA @ 6' FROM EXHAUST
- 72 dBA @ 6' FROM EXHAUST WITH HEPA AFTERFILTER

**OPTIONAL ATTACHMENTS:**

- BACKDRAFT HOOD, DOWNDRAFT TABLE,
- SOURCE CAPTURE ARMS WITH HOODS 6" X 7', 6" X 9', 8" X 7', OR 8" X 9'; - w or w/o LIGHTS
- DUAL 4" X 5' or 4" X 7' SOURCE CAPTURE ARMS W / HOODS;
- 8" X 15' FLEX HOSE W/ MAGNETIC HOOD; 8" X 25' FLEX HOSE W/ MAGNETIC HOOD.

SPECIFICATIONS SUBJECT TO CHANGE WITHOUT NOTICE