



MODEL TM1000

Installation and Operation Manual



Important:

This manual contains specific cautionary statements relative to worker safety. Read this manual thoroughly and follow as directed. It is impossible to list all the hazards of dust control equipment. All persons involved with the equipment or systems should be instructed how to operate in a safe manner.

MODEL TM1000 SPECIFICATIONS

INPUT VOLTAGE:

120V 60Hz 1 Phase
208-230V / 460V 60Hz 3 Phase

MAX. CURRENT:

17 Amps (at 120V, 1 1/2HP, Single Phase)
5.2 Amps (at 208-230V, 1 1/2HP, Three Phase)
2.6 Amps (at 460V, 1 1/2HP, Three Phase)

MOTOR:

TEFC 1 1/2 HP, 1 Phase
TEFC 1 1/2 HP, 3 Phase

COMPRESSED AIR:

80 psi minimum / 90 psi. maximum, clean, dry air. 1/4" NPT male nipple connection.

DUST TRAY CAPACITY:

528 cubic inches

EXTERNAL ARM:

7 ft. or 9 ft. long, 6" or 8" diameter steel tube with 350 degree movement and two joints.

DIMENSIONS: 44-1/2" h. X 25-1/2" w. X 32-1/2" l.

SHIPPING WEIGHT: 350 lbs.

ACTUAL WEIGHT: 300 lbs.

PACKAGE CONTENTS:

- 1 Ea. TM1000
- OPTIONS (These items are separately packed):**
- 1 ea. 6" or 8" dia., 7' or 9' Arm Assembly
- 1 ea. 4" dia. Dual Arm Assembly
- 1 ea. Down Draft Table
- 1 ea. Back Draft Hood
- 1 ea. Magnetic Hood Assembly with 15' or 25' Hose

Caution:

⚠ All electrical work must be done by a qualified electrician according to local, state and national codes.

PRE-OPERATING INSTRUCTIONS:

NOTE: The following instructions will vary depending on options received.

1. Remove the shipping crate, shipping straps and plastic wrapping from the unit.
2. Remove the TM1000 from the shipping skid and set on a level surface.
3. Remove the attachment option from the shipping carton.
4. Install the arm assembly onto the base unit (Fig. 1).

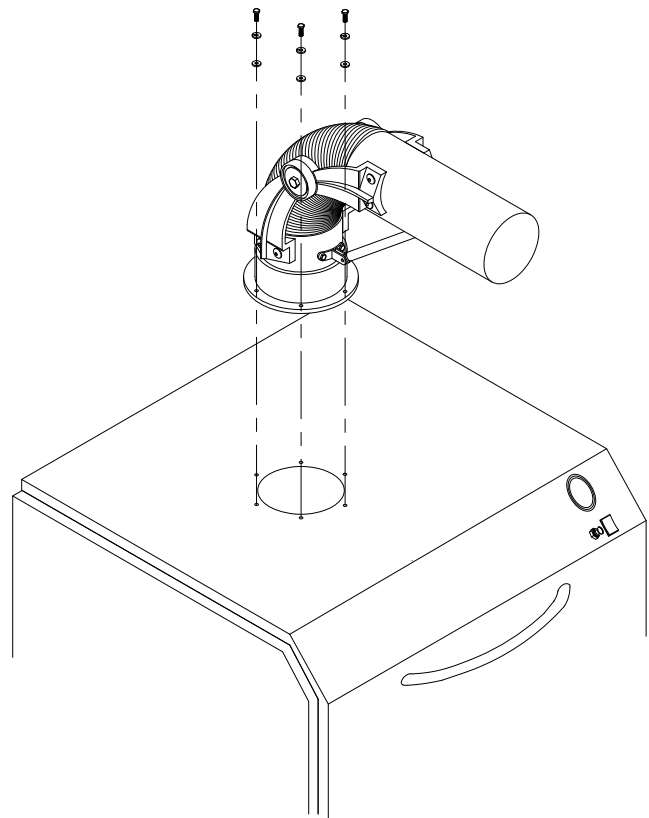

Fig. 1

5. Insert the lamp plug on the arm into the receptacle located directly behind the base of the arm on the TM1000 (Lamp only option).

OPERATING INSTRUCTIONS:

1. Choose a suitable, level place near the workstation and position the unit so that the hose/arm assembly will be placed near the source of pollution being generated. The TM1000 has locking wheels at the front handle end. The wheels are locked by stepping down on the flat plate on the wheels.
2. Grasp the hood by the handle ring and position within 18" of the source of pollution.
3. Plug the power cord into a outlet of the appropriate voltage and phase.

4. Turn the power switch on (located near the Mini-Helic gauge).
5. The light control switch (optional) is mounted on the hood. Turn the light on as needed.
6. Adjust the hood to capture the maximum amount of contaminants. Periodically adjust the position of the hood to keep it in maximum capture range.
7. If the unit fan is rotating incorrectly (three phase only), switch L1 and L2 connections to reverse the rotation direction.

MINI-HELIC GAUGE OPERATION:

1. As the cartridge filters collect airborne pollutants they will eventually begin to become loaded with particulate. The filter loading will cause an increase in static pressure and a decrease in air flow.
2. The Mini-Helic gauge on the control panel indicates static pressure. Note the reading at the initial start-up. As the unit is operated the static pressure will gradually increase as the filters become loaded. This will indicate the need to back flush the system.

CARTRIDGE CLEANING:

NOTE: Pulse clean cartridge filters frequently for proper operations. Failure to do so will decrease performance and lead to pre-mature filter failure.

1. The TM1000 is designed with a Roto-Pulse system to clean the cartridge filters.
2. Attach a shop air hose to the inlet located on the front of the TM1000. It is recommended that a pressure regulator and water trap be installed between the shop air and the TM1000,

NOTE: Do not exceed 90 psi of shop air. Exceeding 90psi will result in filter damage.

3. Shut off the TM1000 blower.
4. Push the cartridge back-flush control button (mounted on the control panel) three or more times. This operation initiates the Roto-Pulse system which spins the tube inside the cartridge filter. As the tube spins, air dislodges the dirty particles from the cartridge filters. These particles then settle into the two removable dust trays.
5. After several cleaning cycles, the dust particles that have been collected by the TM1000 will need to be emptied from the dust trays. The frequency of dust removal depends on the type and quantity of pollutant that is collected. The dust trays should be emptied before the particles have accumulated to a depth of 1/2 inch.
6. To remove the dust trays from the TM1000, turn the unit off. Open the cartridge access door and slide out

the dust trays.

7. Dump the dust out of the trays.
8. Slide dust trays back into the TM1000. Close and latch the filter access door.

CHANGING FILTERS:

Caution:

⚠ Always make sure that the unit is turned off before changing filters or servicing the unit.

1. Turn the TM1000 off and open the filter access door.
2. Remove the cartridge filters retained by wing nuts.
3. Slide new cartridge filters into the cabinet and retain with wing nuts.
4. Close the filter access door.

GENERAL MAINTENANCE:

1. Check the wiring for loose connections for cracked insulation.
4. No lubrication is required for the motor because it is a permanent pre-lube design.
5. Once per month grease the suction arm base assembly with a bearing grease listed to not react with aluminum.

OPTIONAL HEPA / CHARCOAL FILTER INSTALLATION:

KIT CONTENTS:

1. 1 Ea. Left Filter Track
2. 1 Ea. Right Filter Track
3. 1 Ea. Stretch Cord
4. 6 Ea. #8 x 1/2" SMS
5. 1 Ea. HEPA Filter or RCM Module

INSTALLATION:

1. Remove the four (4) screws used to attach the lower panel and remove lower panel from the TM1000.
2. Remove the exhaust restrictor plate
3. Locate filter tracks shown in Fig. 2. Filter tracks are to be located flush to front edge of cabinet bottom and centered above the exhaust opening (align filter track over pre-punched holes).
4. Secure filter tracks to the TM1000 using six (6) each #8 x 1/2" sheet metal screws provided.
5. To install filter, slide the filter in between tracks so that the airflow arrow points downward.
6. Retain the filter with stretch cord provided.
7. Replace the lower panel.

Caution:

⚠ Exhaust restrictor plate is used in lieu of after filters to prevent motor overload. If the after filter is removed, re-install the restrictor plate prior to operating the unit. Failure to do so may result in damage to the motor or electrical circuit.

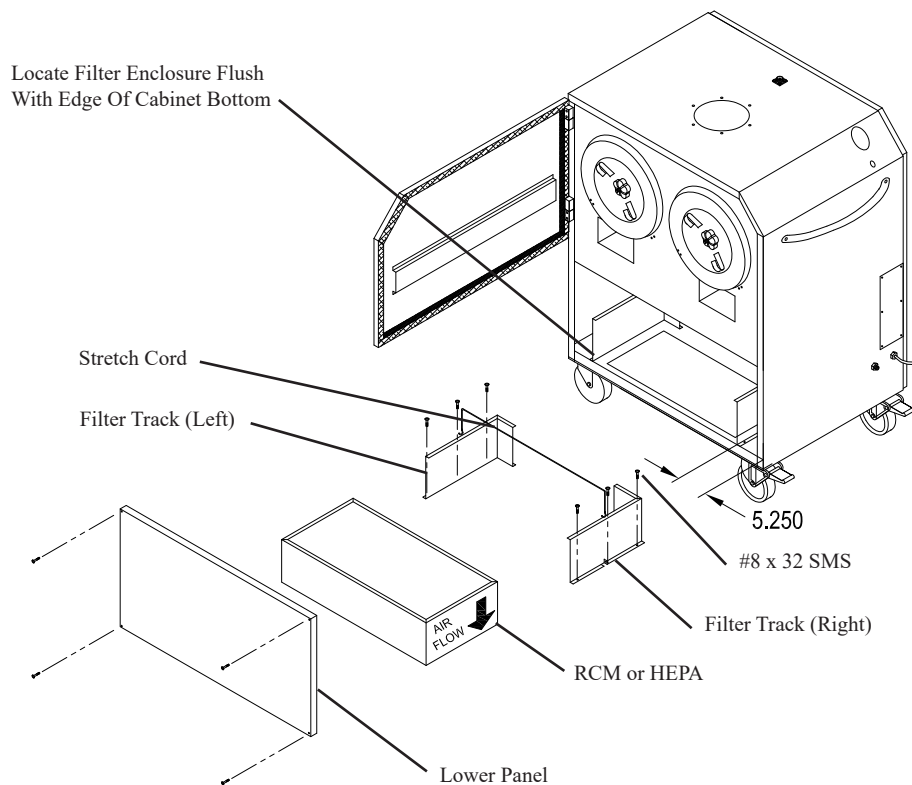

Fig. 2

OPTIONAL BIG WHEEL INSTALLATION:

KIT CONTENTS:

- 1 Ea. Big Wheel Assembly
- 8 Ea. 5/16-18 x 1" Hex Bolt

INSTALLATION:

1. Position the unit on its' side with the bottom exposed.
2. Remove the four (4) bolts, flat washers and lock washers retaining each fixed wheel. Retain the hardware for use in step four.
3. Place the Big Wheel Assembly onto the unit. Align the eight slotted holes over the holes in the unit, making sure that the Big Wheel Assembly presses against the back wall of the unit.
4. Install the lock washer, flat washer and the 1" long hex bolts supplied with the kit. Secure the Big Wheel assembly to the unit with the eight (8) 1" long hex bolts. Make sure the bolts are tight.
5. Position the unit onto the wheels and reattach any attachments removed for installation.

Caution:

⚠ Source capture arms or other attachments must no be attached during kit installation.

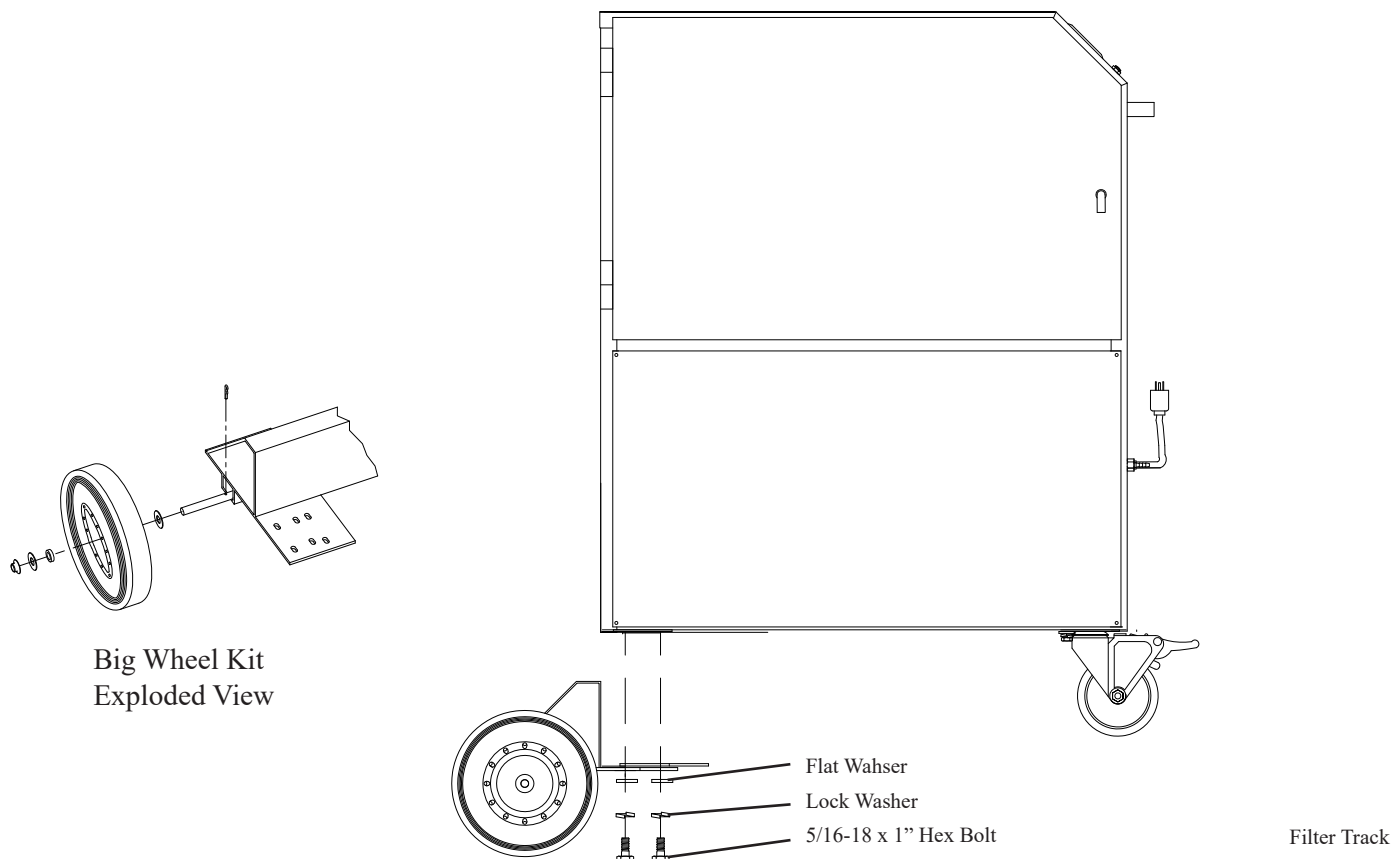

Fig. 3

OPTIONAL BACKDRAFT HOOD INSTALLATION:

KIT CONTENTS:

- 1 Ea. Backdraft Hood
- 1 Ea. Flexible Hose
- 1 Ea. Adapter Collar
- 2 Ea. Hose Clamps

INSTALLATION:

1. Lift and slide the Backdraft Hood into the upper receiving bracket (Fig. 4).
2. Connect the Adapter collar to the top of the TM1000 with the 1/4-20 hardware provided.
3. Place one end of the 8” diameter flex hose over the Backdraft Hood collar .
4. Place the other end of the 8” diameter flex hose over the Adapter collar.
5. Secure both ends of the 8” diameter flex hose with the supplied hose clamps.

NOTE: 15’ and 25’ hose lengths are available to allow the Backdraft Hood to be remote located.

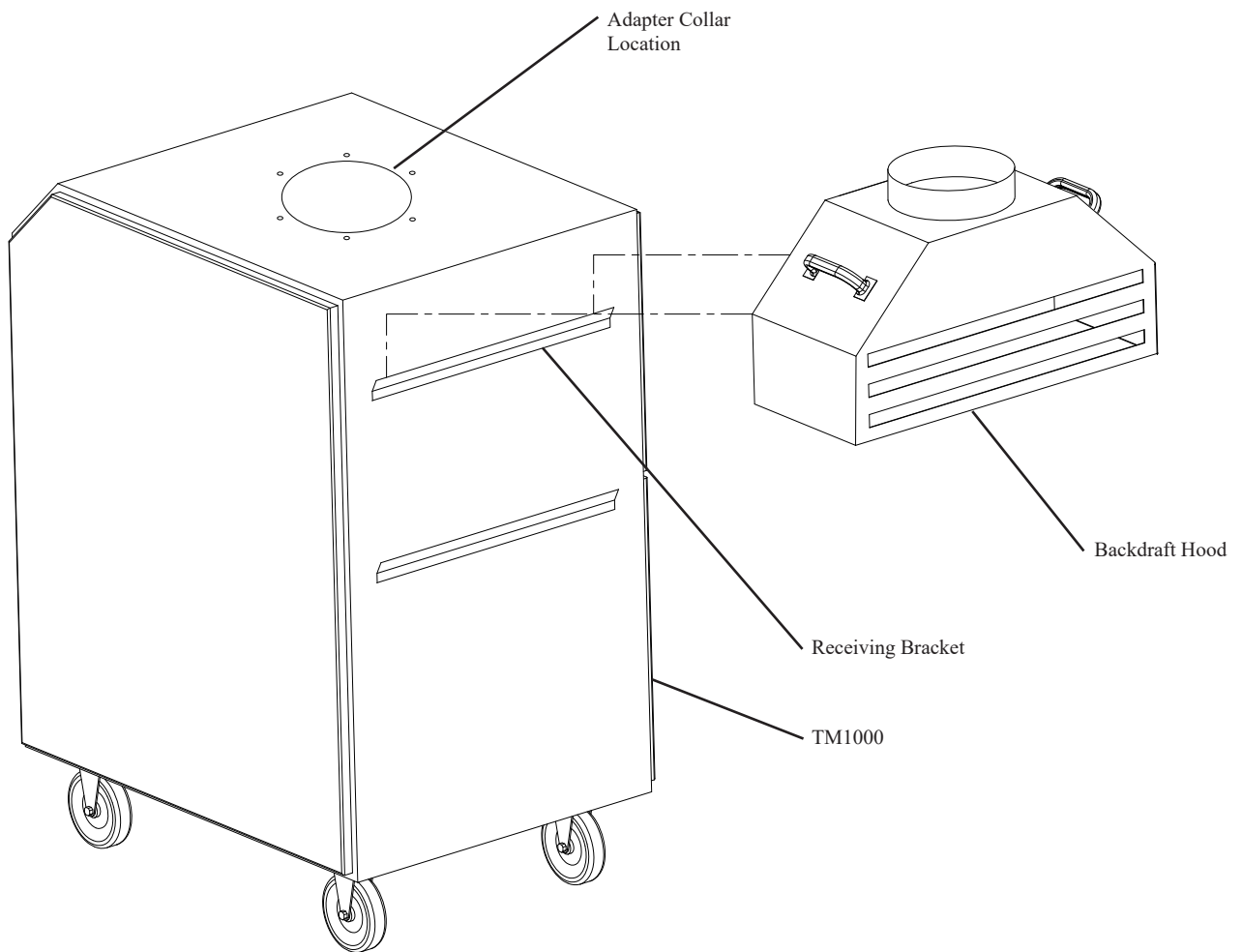

Fig. 4

OPTIONAL DOWNDRAFT TABLE INSTALLATION:

KIT CONTENTS:

- 1 Ea. Downdraft Table
- 1 Ea. Flexible Hose
- 1 Ea. Adapter Collar
- 2 Ea. Hose Clamps

INSTALLATION:

1. Lift and slide the Downdraft Table into the lower receiving bracket (Fig. 5).
2. Connect the Adapter collar to the top of the TM1000 with the 1/4-20 hardware provided.
3. Place one end of the 8" diameter flex hose over the Downdraft Table collar .
4. Place the other end of the 8" diameter flex hose over the Adapter collar.
5. Secure both ends of the 8" diameter flex hose with the supplied hose clamps.

NOTE: 15' and 25' hose lengths are available to allow the Backdraft Hood to be remote located.

Caution:

⚠ Force placed upon Downdraft Table must not exceed 50 lbs. when attached to the TM1000. Do not exceed 300 lbs. when remote mounted.

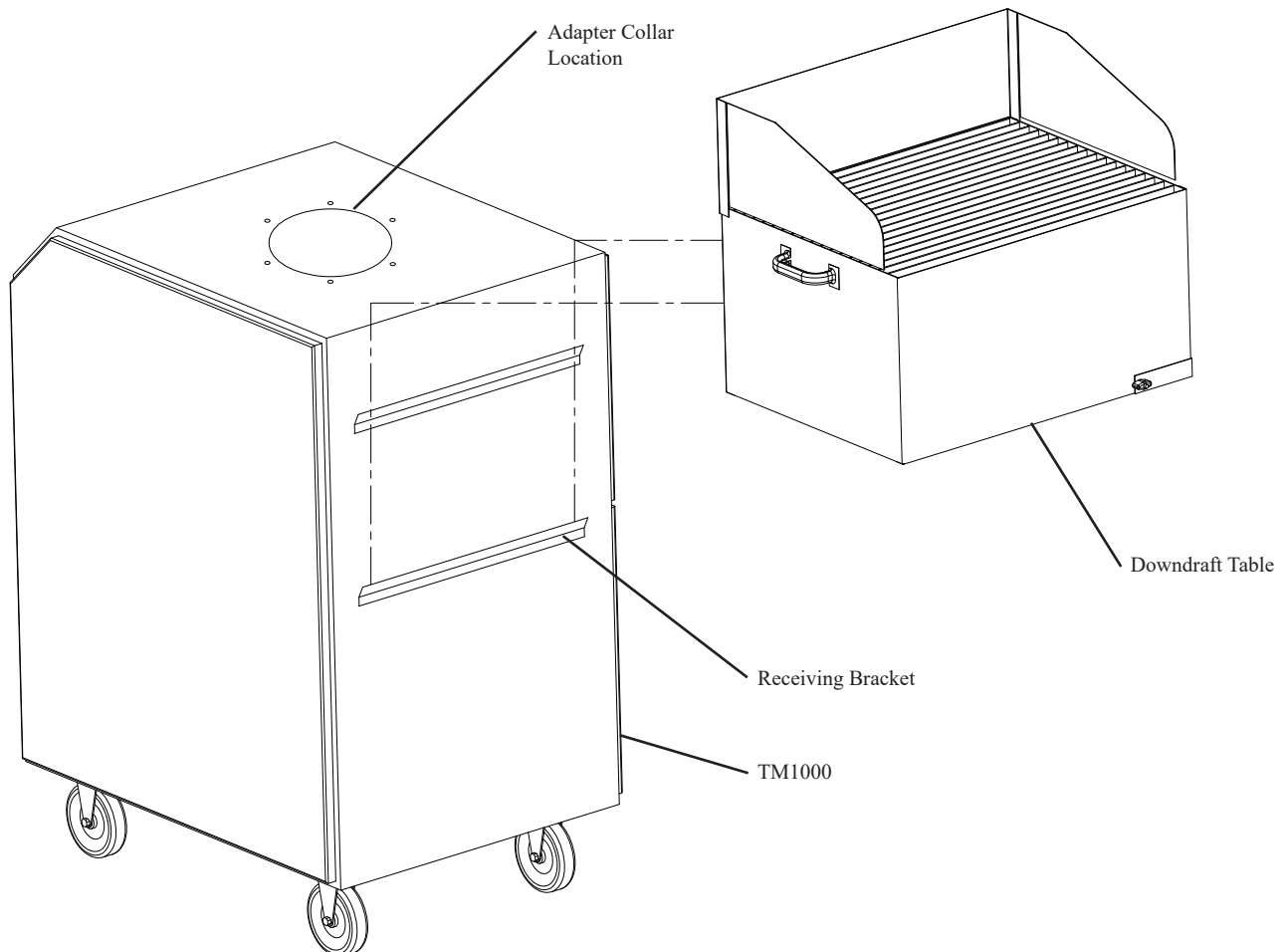

Fig. 5

TM1000 WIRING DIAGRAMS

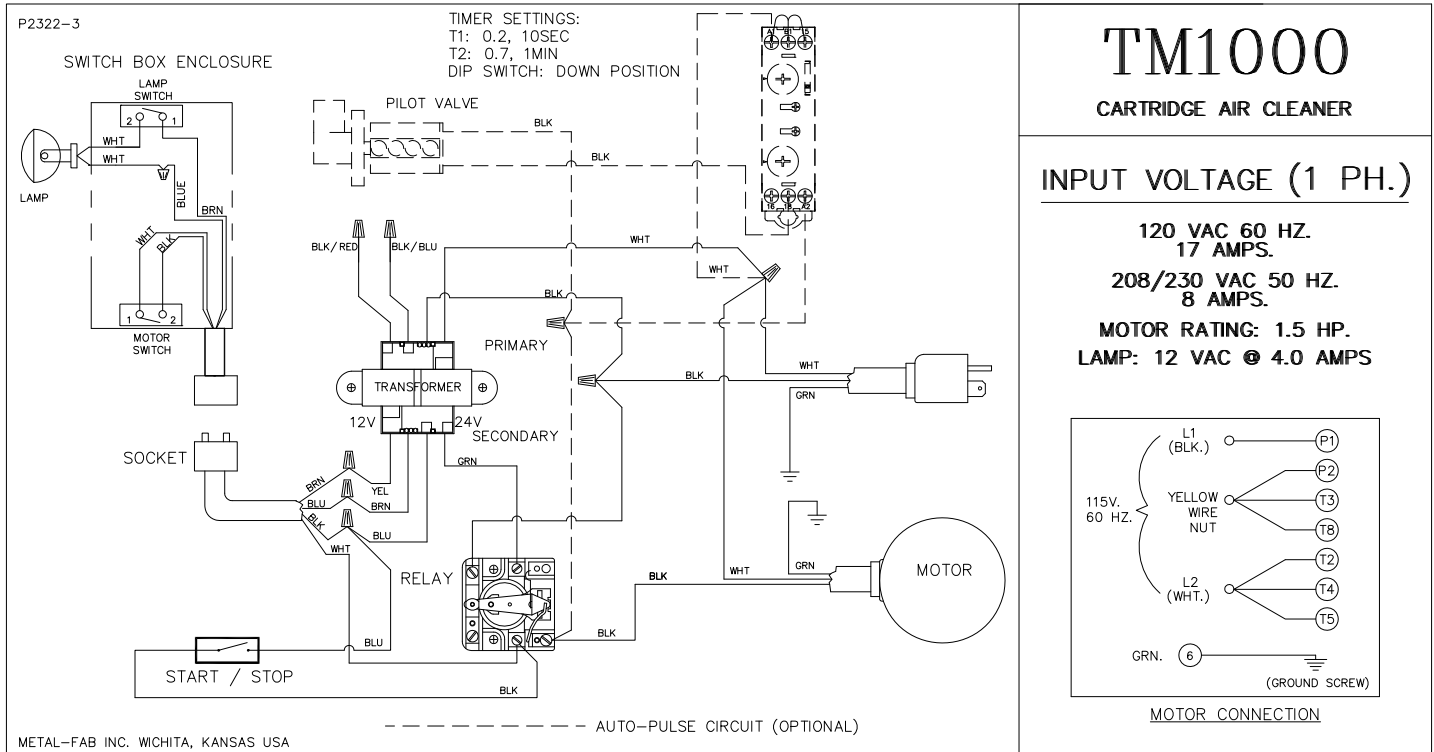

Fig. 6A

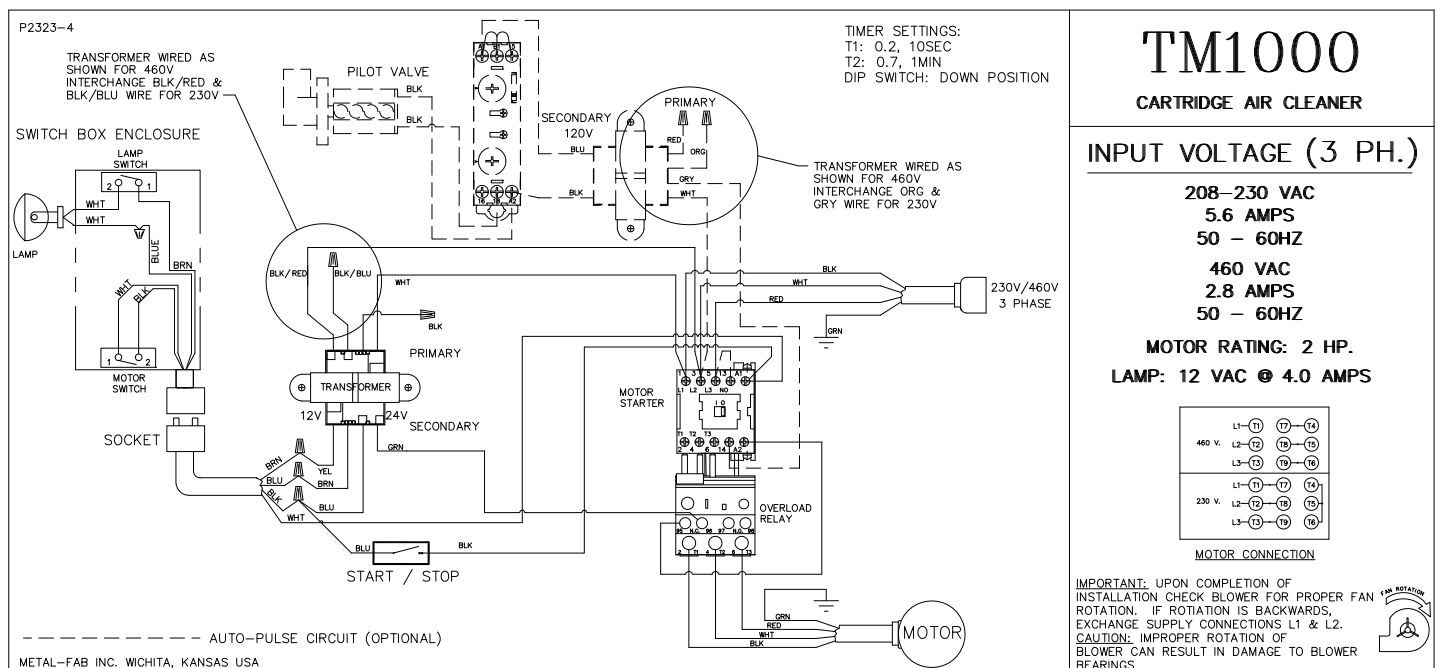

Fig. 6B

6" & 8" DIAMETER ARM ASSEMBLY PARTS LIST

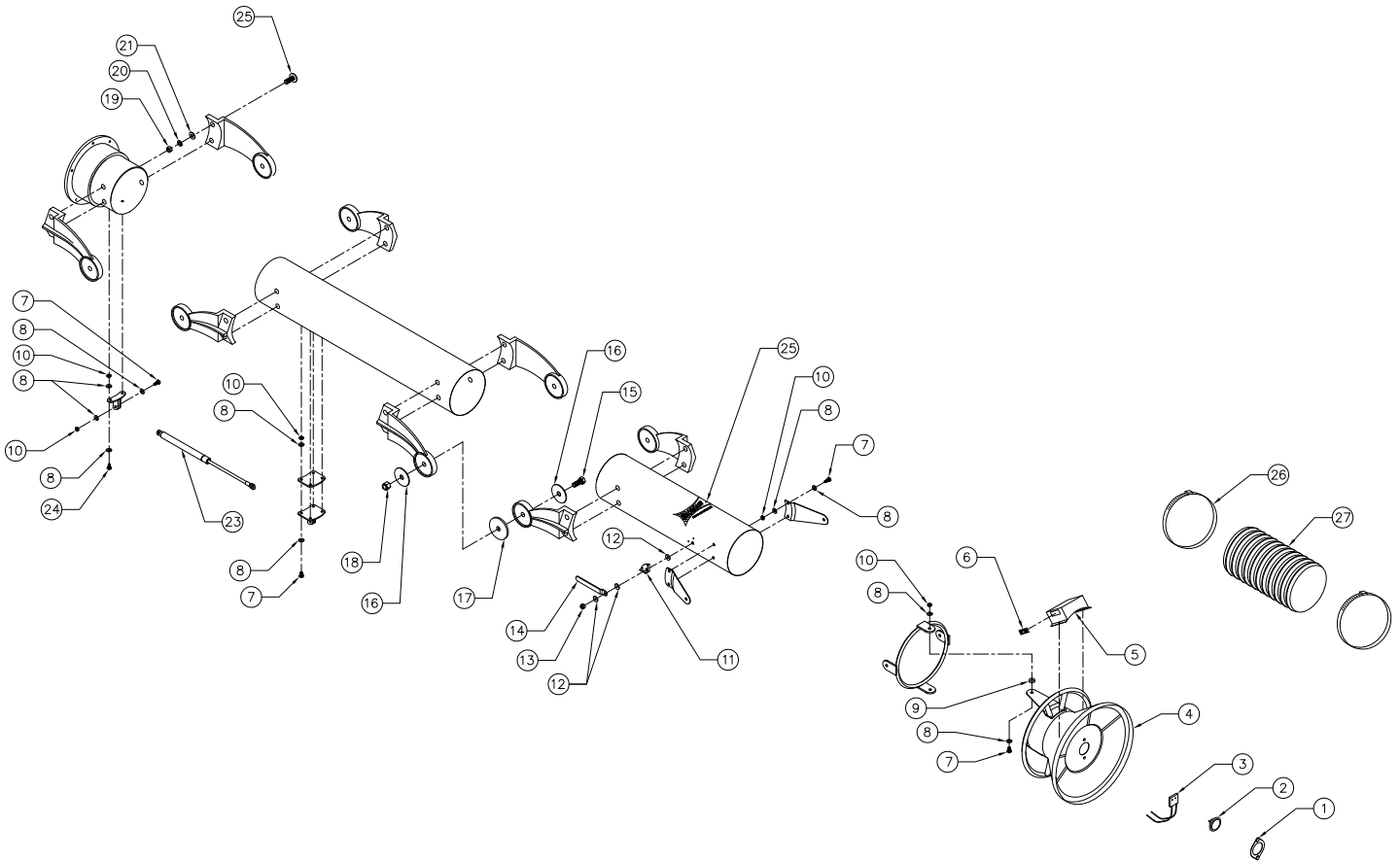

Fig. 7

ITEM	PART NO.	DESCRIPTION	ITEM	PART NO.	DESCRIPTION
1.	37107-01	Lamp Plate	16.	P2468	Cup Washer
2.	P2170	Lamp	17.	P2467	Friction Pad
3.	P2168	Lamp Socket	18.	P2479	1/2-13 Nylock Hex Nut
4.	P2466	6" Hood Assembly	19.	P141	3/8-16 Hex Nut
	P2469	8" Hood Assembly	20.	P142	3/8" Lock Washer
5.	37106-01	Switch Box	21.	P2206	Flat Washer
6.	P2219	Rocker Switch	22.	P2481	3/8-16 x 1.25" Carriage Bolt
7.	P164	1/4-20 x 3/4" Hex Head Bolt	23.	P2461	6" Gas Shock
8.	P246	1/4 Flat Washer		P2462	8" Gas Shock
9.	P2482	Hood Disc Pad	24.	P2483	1/4-20 x 1" Hex Head Bolt
10.	P2485	1/4-20 Nylock Hex Nut	25.	P2312	Micro Air Decal
11.	37104-01	Damper Handle Stop Plate	26.	P2232	Hose Clamp
12.	P2206	5/16" Flat Washer	27.	P2491	6" Dia. Flex Hose
13.	P2484	5/16" Nylock Hex Nut		P2617	8" Dia. Flex Hose
14.	37103-01	Damper Handle	N/S	P2471	4 Conductor Cable - 9' long
15.	P2478	1/2-13 x 2.25" Hex Head Bolt	N/S	P2472	4 Conductor Cable - 15' long

4" DIAMETER ARM ASSEMBLY PARTS LIST

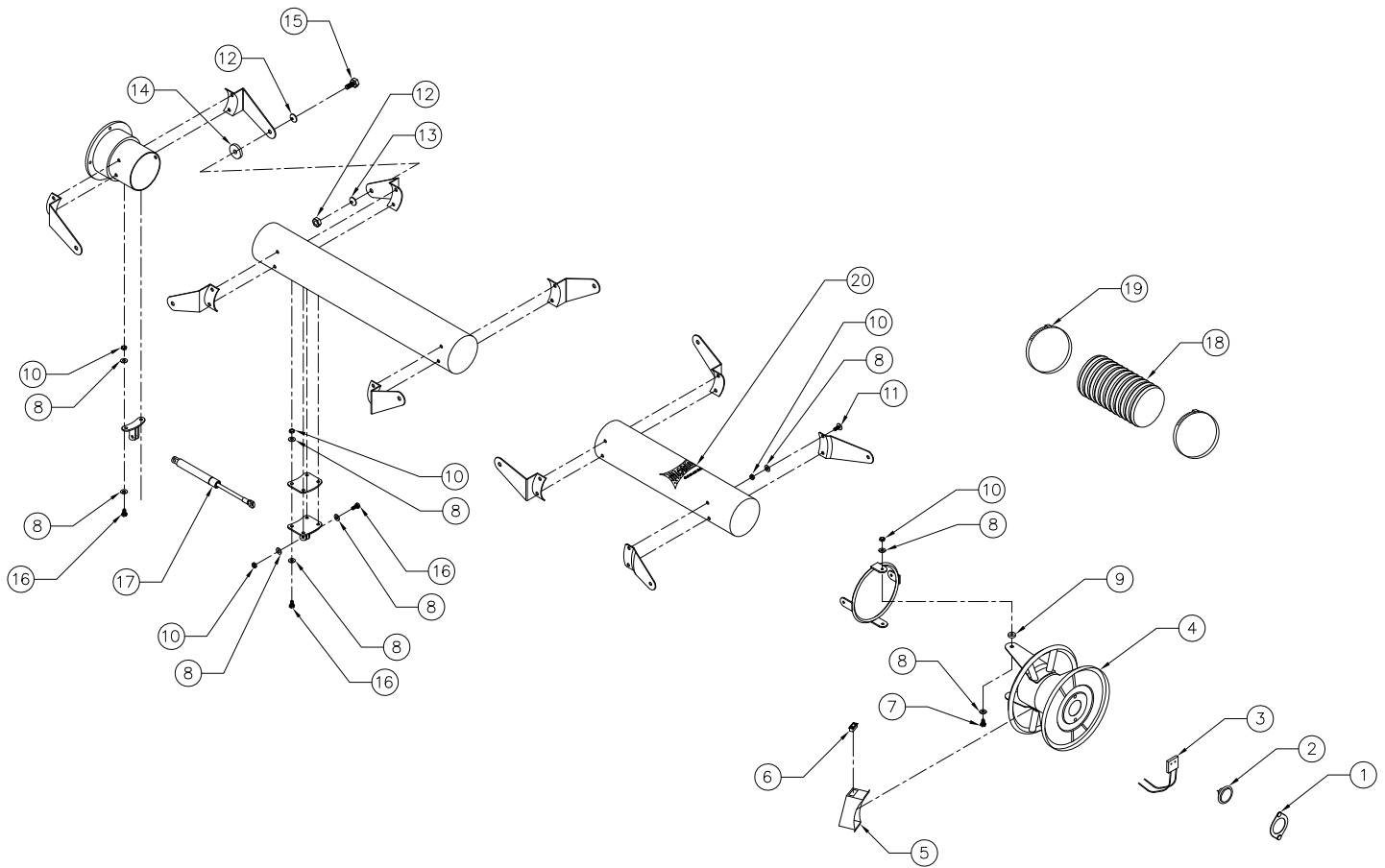

Fig. 8

ITEM	PART NO.	DESCRIPTION	ITEM	PART NO.	DESCRIPTION
1.	37107-01	Lamp Plate	12.	P2484	5/16" Nylock Hex Nut
2.	P2170	Lamp	13.	P2465	Cup Washer
3.	P2168	Lamp Socket	14.	P2464	Friction Pad
4.	P2463	4" Hood Assembly	15.	P2614	5/16-18 x 1" Hex Head Bolt
5.	37106-01	Switch Box	16.	P164	1/4-20 x 3/4" Hex Head Bolt
6.	P2219	Rocker Switch	17.	P2460	4" Gas Shock
7.	P2483	1/4-20 x 1" Hex Head Bolt	18.	P2470	4" Dia. Flex Hose
8.	P246	1/4 Flat Washer	19.	P2232	Hose Clamp
9.	P2482	Hood Disc Pad	20.	P2312	Micro Air Decal
10.	P2485	1/4-20 Nylock Hex Nut	N/S	P2471	4 Conductor Cable - 9' long
11.	P2490	1/4-20 x 1" Carriage Bolt	N/S	P2472	4 Conductor Cable - 15' long

TM1000 PARTS LIST

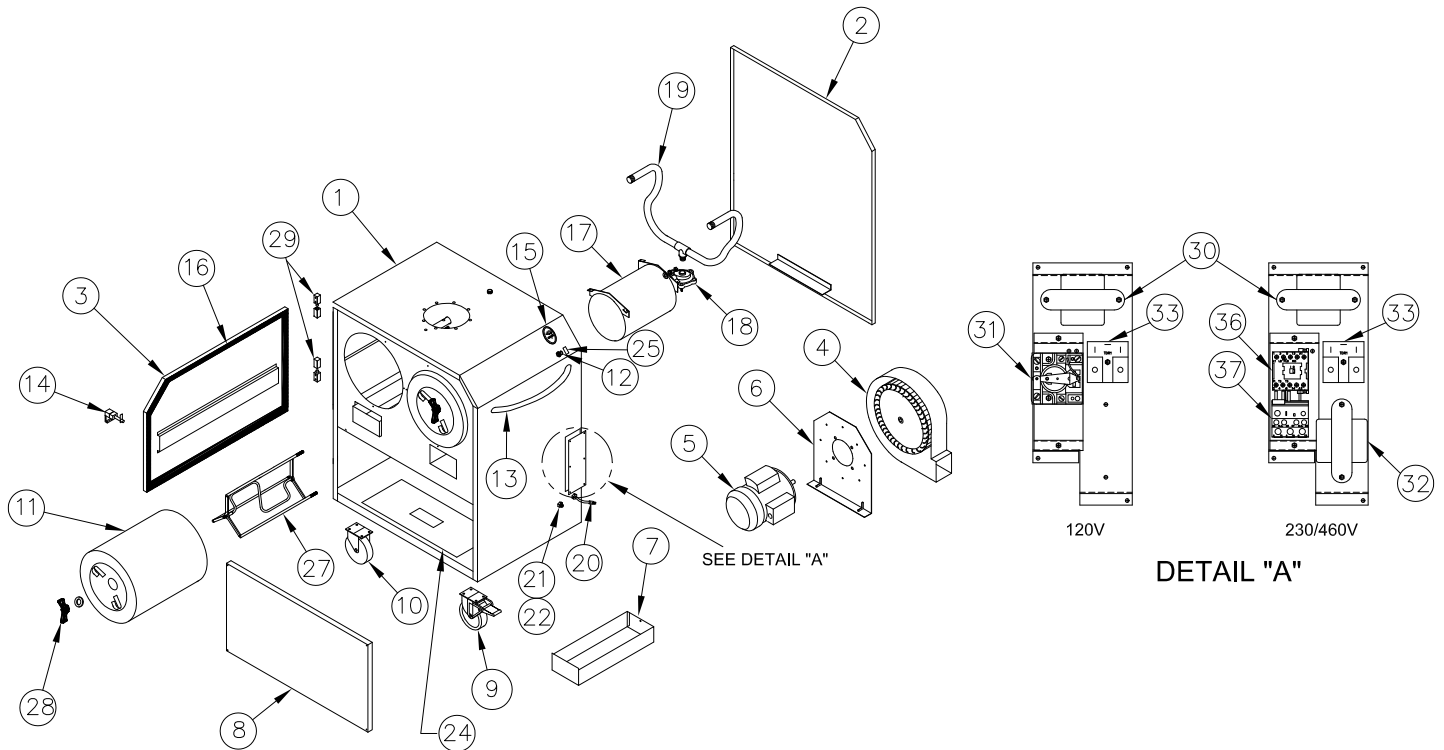

Fig. 9

ITEM	PART NO.	DESCRIPTION	ITEM	PART NO.	DESCRIPTION
1.	38551-01	Cabinet	*16.	P1367	3/4" x 1" Foam Gasket
2.	34331-02	Back Panel	17.	36712-01	Accumulator Tank
3.	34294-02	Filter Door	18.	P2075	Diaphragm Valve
4.	P2302	Blower	19.	36723-03	Tee Assembly
5.	P2301	Motor (120V)	20.	P1363	Cord Set (120V)
	P2320	Motor (208/230-460V, 3-Phase)	21.	P2222	1/4" Barb x 1/8" Female NPT
6.	34363-01	Motor Plate	22.	P2210	1/8" Male x 1/4" Male Hex Nipple
7.	34227-01	Dust Tray Weldment	24.	38561-01	Exhaust Restrictor Plate
8.	34332-01	Lower Panel	25.	P2219	Rocker Switch
9.	P1304	Swivel Caster	27.	36720-04	Roto-Pulse Assembly
10.	P1313	Fixed Caster	28.	P3649	Wing Knob
11.	P7402RM	80/20 Cartridge Filter	29.	P2835	Hinge
	P7407RM	Spunbond Cartridge Filter	30.	P2534	Transformer
	P7417NM	Nanofiber Cartridge Filter	31.	P2078	Relay
12.	P2766	Push Button Air Valve	32.	P1754	Transformer
13.	P2215	Handle	33.	P2922	Timer
14.	P1372	Latch	36.	P3909	Motor Starter Relay
15.	P2221	Mini-Helic Gauge	37.	P3914	Overload Relay

* Specify Length Required

TM1000 ACCESSORIES PARTS LIST

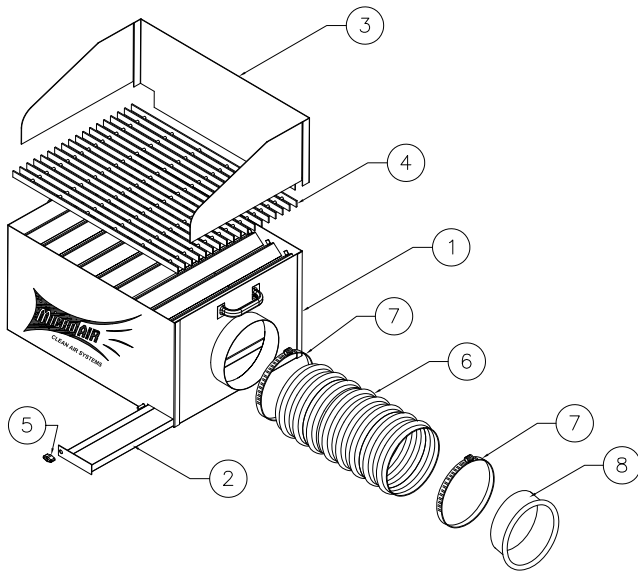

Fig. 10

DOWNDRAFT TABLE		
ITEM	PART NO.	DESCRIPTION
1.	38570-01	Downdraft Assembly
2.	38576-01	Cleanout Drawer
3.	38579-01	Shield Assembly
4.	P2314	Steel Grate
5.	P3506	Wing Nut
6.	P2319	Hose (Qty. 6 ft.)
7.	P2232	Hose Clamp
8.	37123-02	Adapter Plate

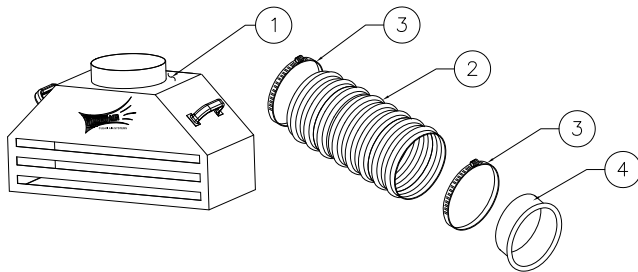

Fig. 11

BACKDRAFT TABLE		
ITEM	PART NO.	DESCRIPTION
1.	38499-01	Backdraft Assembly
2.	P2319	Hose (Qty. 5 ft.)
3.	P2232	Hose Clamp
4.	37123-02	Adapter Plate

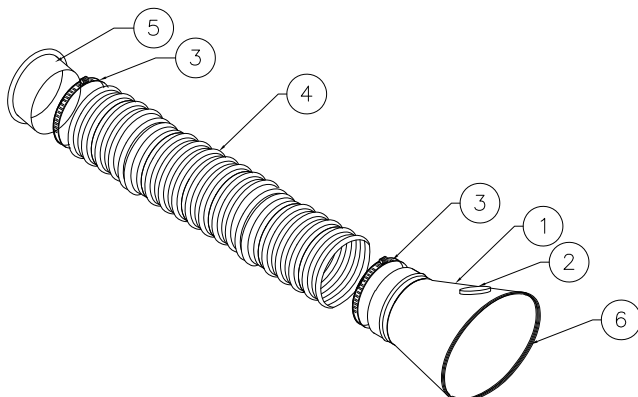

Fig. 12

MAGNETIC HOOD		
ITEM	PART NO.	DESCRIPTION
1.	38569-01	Hood Assembly
2.	P2303	Magnet
3.	P2232	Hose Clamp
4.	P2319	Hose (Qty. 15 ft. or 25 ft.)
5.	37123-02	Adapter Plate
6.	P1342	Edge Guard

TROUBLE SHOOTING CHART

CAUTION: BEFORE DISASSEMBLING THE UNIT OR DOING ANY INSPECTING OF THE PARTS, MAKE CERTAIN THAT THE POWER HAS BEEN CUT OFF AND THE BLOWER HAS COME TO A COMPLETE STOP. NEVER RUN THE UNIT WITH THE ACCESS DOOR OPEN OR REMOVED.

PROBLEM	POSSIBLE CAUSE	REMEDY
Unit fails to start	No incoming power Blown breaker or fuse Primary voltage to motor contactor is below 10% tolerance Burned out motor Tripped overload (3 Phase) Thermal trip (120V)	Check line voltage Replace fuse or throw breaker Take steps to increase voltage to primary Replace motor Reset overload protector Reset thermal trip
Unit runs slowly or inadequate capture velocity	Wired for wrong voltage or improper rotation Dirty filters Internal obstruction	Check input voltage Check wiring diagram Switch L1 & L2 (3-phase only) Service / Replace filters Check if damper is open Check inlet for blockage Check hoses for proper connection Check hoses for holes
Vibration	Loose mounting bolts Foreign objects in blower Dirty disposable filters	Tighten bolts Remove debris from blower Service or replace filters
Unit runs for a short period of time and stops	Exhaust restrictor plate removed Incorrect extension cord size (120V)	Re-install Restrictor plate Plug directly into outlet Use a cord rated to 20 Amps
Stronger resistance during rotation of the arm	Lack of grease in the rotating socket	Grease the rotating socket
Arm will not stay where it is placed	The joints are loose	Tighten the joints

Serial Number:

Supply Voltage:

Date Installed:

Installed By:

Notes: