

MICROAIR[®]

AIRCLEANERS

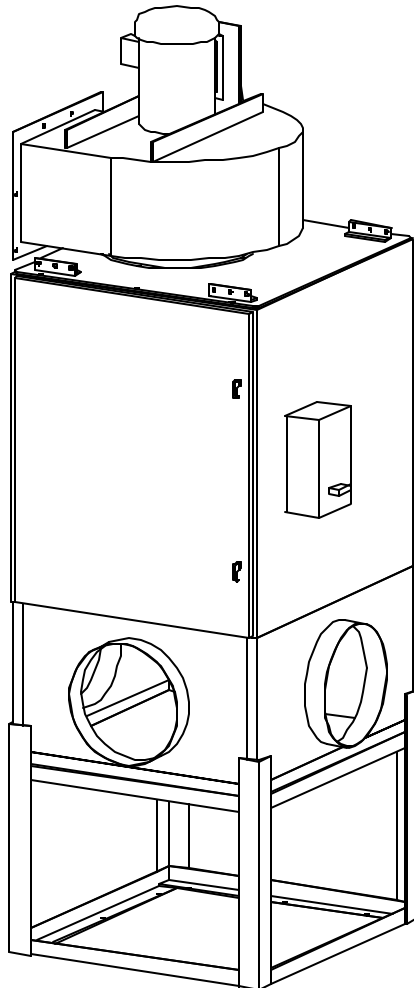

Model OM 6000DD

OWNER'S MANUAL

CAUTION

Read complete instructions before operating.
Please file for future reference.

MODEL OM 6000DD SPECIFICATIONS

Input Volts: 208-230/460 VAC, 60 Hz, 3-Phase

Motor Specs:	Height	Weight
3HP: 208-230V / 9 amps 460V / 4.5 amps	117-3/4"	570 lbs.
5 HP: 208-230V / 15 amps 460V / 7.5 amps	121"	620 lbs.
7.5 HP: 208-230V / 22 amps 460V / 11 amps	124"	655 lbs.
10 HP: 208-230V / 27 amps 460V / 14 amps	126"	760 lbs.
15 HP: 208-230V / 38 amps 460V / 19 amps	126-1/2"	795 lbs.

PACKAGE CONTENTS**

- 1 EA. Filter Module Assembly
- 1 EA. Inlet Plenum
- 1 EA. Floor Stand
- 1 EA. Owner's Manual
- 1 EA. Motor Blower Assembly

** Contents may vary due to CTO configuration ordered.

UNPACKING INSTRUCTIONS

1. Cut the shipping straps, remove the carton and plastic wrapping from the unit.
2. Remove the OM 6000DD from the shipping skid.
3. Remove the Motor/Blower from the skid.
4. Inspect the unit for any possible damage that may have occurred during shipping. File any damage claims with the delivery freight carrier upon receipt of the unit.

LOCATION CRITERIA

- Three feet of unobstructed exhaust space from outlet of the unit.
- Allow sufficient room to access the front and back of the unit for servicing and maintenance.
- Place as near as possible to the source of oil mist or other pollutant that is to be captured.
- Four foot by four foot level cement area for mounting the unit.

MOUNTING

FLOOR MOUNT

1. Locate an installation site on a level surface that meets the location criteria.
2. Bolt the floor stand securely to the floor (See Fig. 1.)

CAUTION: Failure to bolt the floor stand to the floor may cause serious bodily injury

3. Place inlet plenum and filter module assembly onto the stand. Using lifting lugs on top of unit

CAUTION: The size and weight of the OM 6000DD requires a mechanical means to lift and hold the unit during installation.

4. Secure the unit to the stand, using the provided 3/8" hardware. seal with RTV sealant. (See Fig. 1.)
5. Lift the Motor/Blower using the four lifting lugs.
6. Attach foam to bottom of blower.
7. Orient the Motor/Blower over the hole in the top of the cabinet (refer to page 6).
8. Align the holes in the blower flange with holes on the adapter plate, then lower the motor until it is sitting on the adapter plate.
9. Securely bolt the Motor/Blower to the unit using provided 3/8" hardware. (refer to page 7).

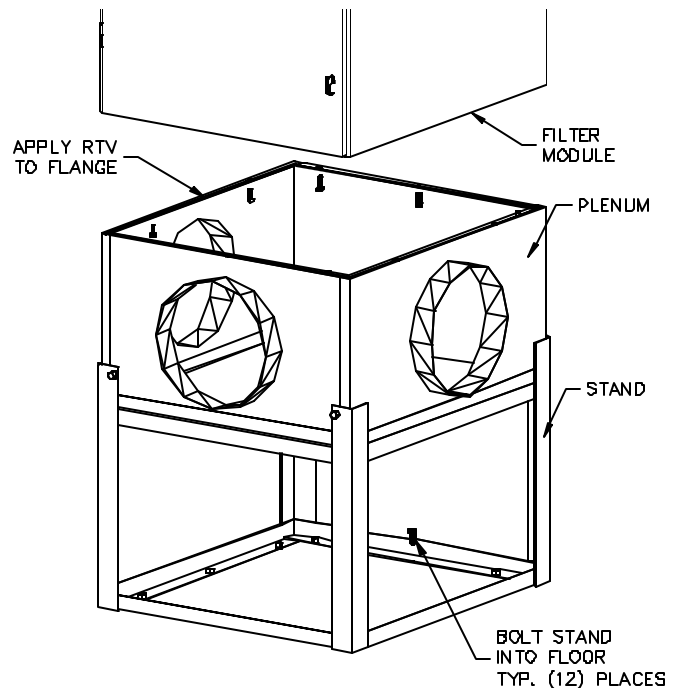

Fig. 1

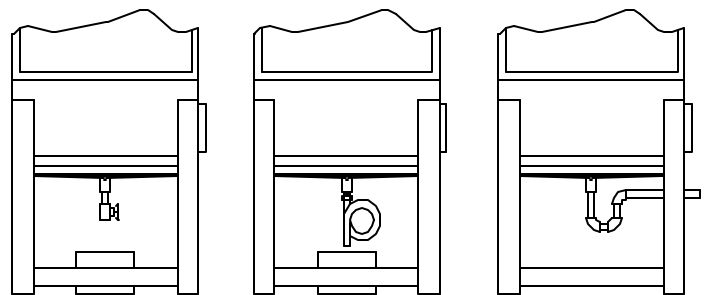

Fig. 2

OIL DRAINAGE

NOTE: Make sure to follow local codes when disposing of captured oil.

Provisions for draining oil from unit is provided for by a 1" N.P.T. pipe coupling on the bottom of the unit. Drainage can be piped to a central collection system or collected in a bucket placed under the unit. In all cases a shut-off valve or drain trap is required to prevent air by-pass through the drain opening. One of the drain systems shown in Figure 2 should be used. Drain connections and lines are not provided.

NOTE: If a shut-off is installed in the drain system, the unit must be emptied regularly to prevent oil from overflowing into the intake duct.

ELECTRICAL CONNECTIONS

CAUTION: Installation can cause exposure to live electrical components. Disconnect electrical power before proceeding with installation.

1. Conduit electrical connection should be made by a qualified electrician, and must comply with local electrical codes.

NOTE

2. Make electrical connections from power supply to L1, L2, and L3. Wire size should be suitable for applicable motor load. (Refer to motor name plate). See Wiring Diagram.

IMPORTANT: Measure motor current upon installation of OM 6000DD. Excessive current will cause overload protection to engage resulting in shutdown of system motor.

3. If motor current is higher than rated DO NOT continue operation. Check for correct motor/blower rotation, supply voltage during start-up, and all wiring connections. If further assistance is required contact your Micro Air representative.

OPERATION

MAGNEHELIC GAUGE OPERATION (IF APPLICABLE)

1. As the filters collect airborne pollutants, they will eventually begin to become "loaded", which will cause an increase in static pressure and a decrease in airflow.
2. The Magnehelic gauge (optional) on the control panel indicates static pressure. Note the reading at the initial start-up. As the unit is operated, the static pressure will gradually increase as the filters become loaded. This will indicate the need to clean or change the filters.

CAUTION: OPERATION WITHOUT A SILENCER CAN CAUSE EXPOSURE TO MOVING BLOWER. KEEP ALL OBJECTS CLEAR OF BLOWER

CHANGE FILTERS

1. Turn off unit.
2. Open filter access door. (If additional access is required the back filter access panel may be removed. Although this should not be necessary).
3. Remove only the Prefilter from the unit.
 - A. Baffle Impinger and Mesh Prefilters
Wash these prefilters in a detergent solution to remove dirt and oil residue. Rinse them thoroughly with water, shake dry and replace them in the unit with the airflow direction pointing to the blower.
 - B. Pleated Prefilters
Replace with a new filter with the airflow direction pointing to the blower.
4. Close the access door and reinstall back panel if removed.
5. Turn unit on, if Magnehelic gauge is still indicating high static pressure, then the bag filter needs to be replaced.
6. Visually inspect the bag filter. If the pockets are loaded with oil and dirt, then remove the filters by disconnecting the filter rod from the unit and disengaging the positive sealing system.
7. To install new bag filters slide two filters in back to back on one side of the unit. Run two filter rods through the loops on both bags. Install the rods in the appropriate locations at the front and back of the unit. Lock the positive sealing cams into position (Refer to **Figure 3**). Repeat this process with the other two filters.
8. Close the door and turn the unit on.

GENERAL MAINTENANCE

1. Periodically, inspect hardware for loose nuts and bolts on access doors and internal components. Tighten, if needed.
2. Periodically, inspect all wiring for loose connections and cracked insulation. Replace as needed.
3. Periodically, check that the oil is draining easily through the drain pipe.

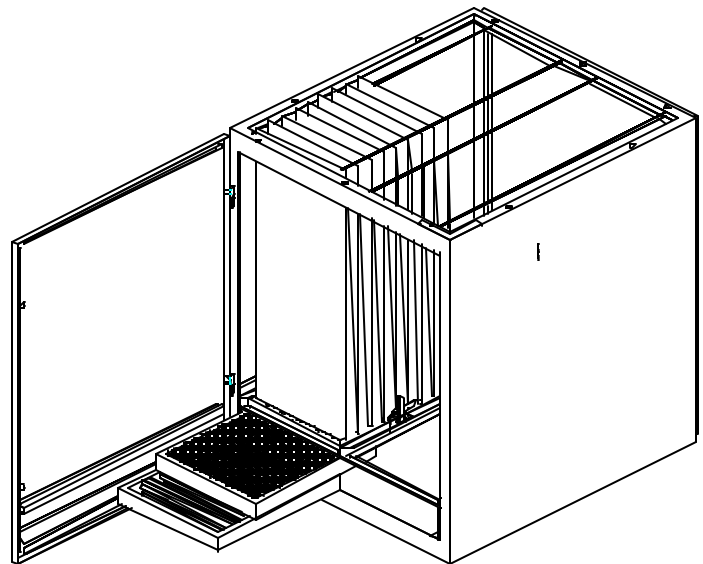
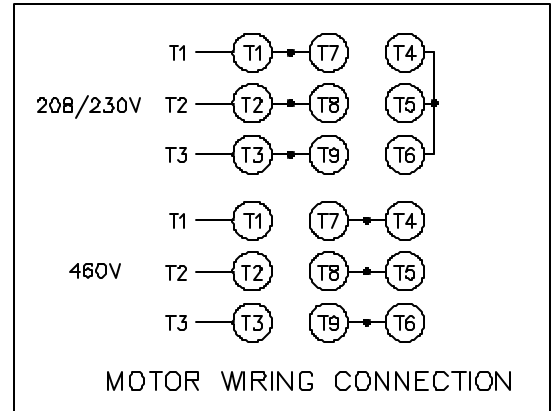
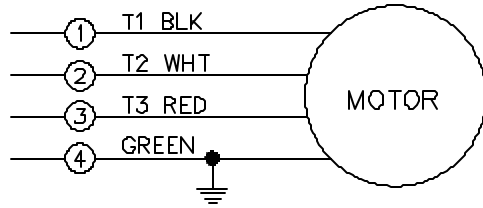

FIG. 3

TROUBLESHOOTING CHART**CAUTION:**

BEFORE DISASSEMBLING THE UNIT OR DOING ANY INSPECTING OF THE PARTS, MAKE CERTAIN THAT THE POWER HAS BEEN CUT OFF AND THE BLOWER HAS COME TO A COMPLETE STOP. NEVER RUN THE UNIT WITH THE ACCESS DOORS OPEN OR REMOVED.

PROBLEM	POSSIBLE CAUSE	REMEDY
Unit Fails to Start	Dead Power Line Blown Fuse or Breaker Overload Protection Engaged Burnt Out Motor	Check Circuit and Switch Check Fuse or Breaker Reset Overload Protect Replace Motor
Unit Runs Slowly or Inadequate Capture Velocity	Wired for Wrong Voltage or Improper Rotation Dirty Filters	Check Input Voltage Switch L1 & L2 to Reverse Rotation Check Wiring Diagram Clean or Replace Filters
Vibration	Loose Motor Mount Bolts Foreign Object in Blower Dirty Disposable Filters	Tighten Bolts Remove Debris from Blower Service Filters



STANDARD WIRING

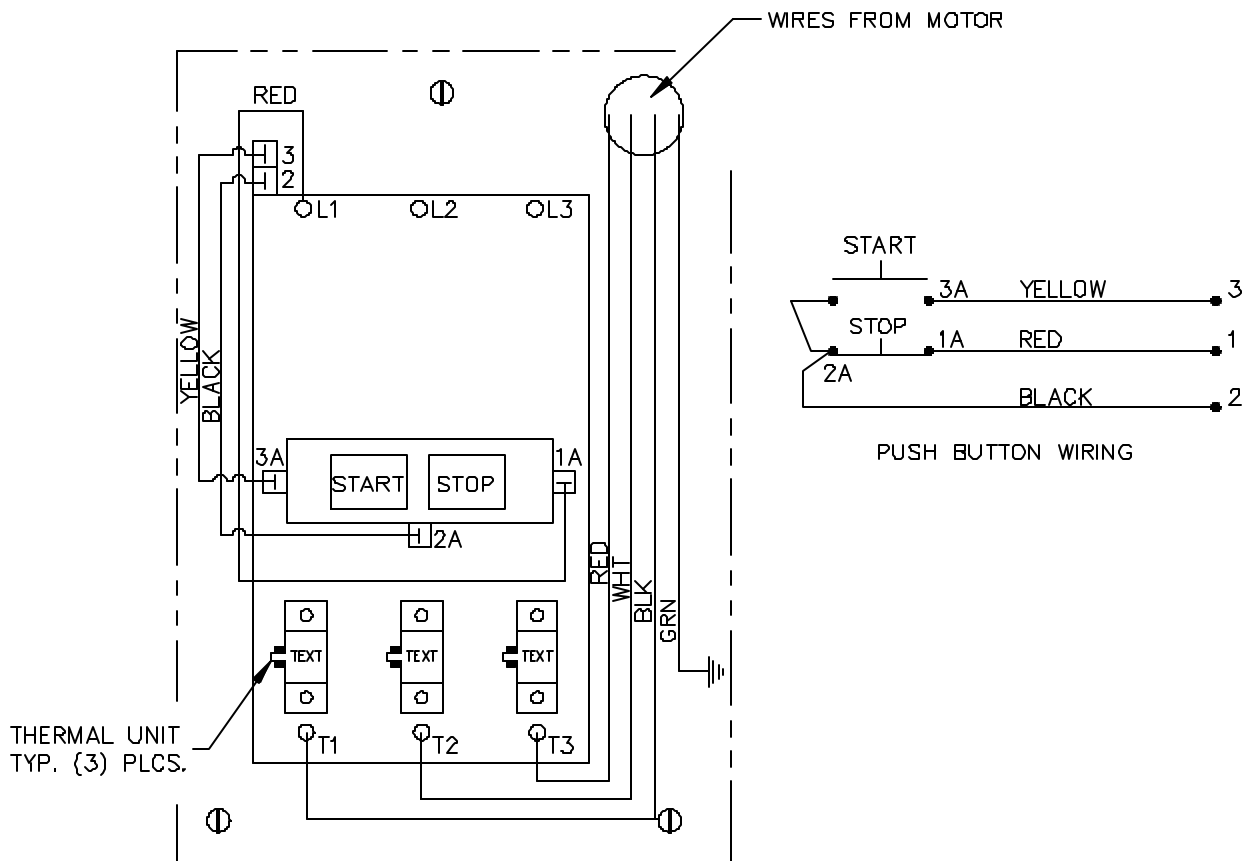

OPTIONAL CTO MOTOR STARTER WIRING

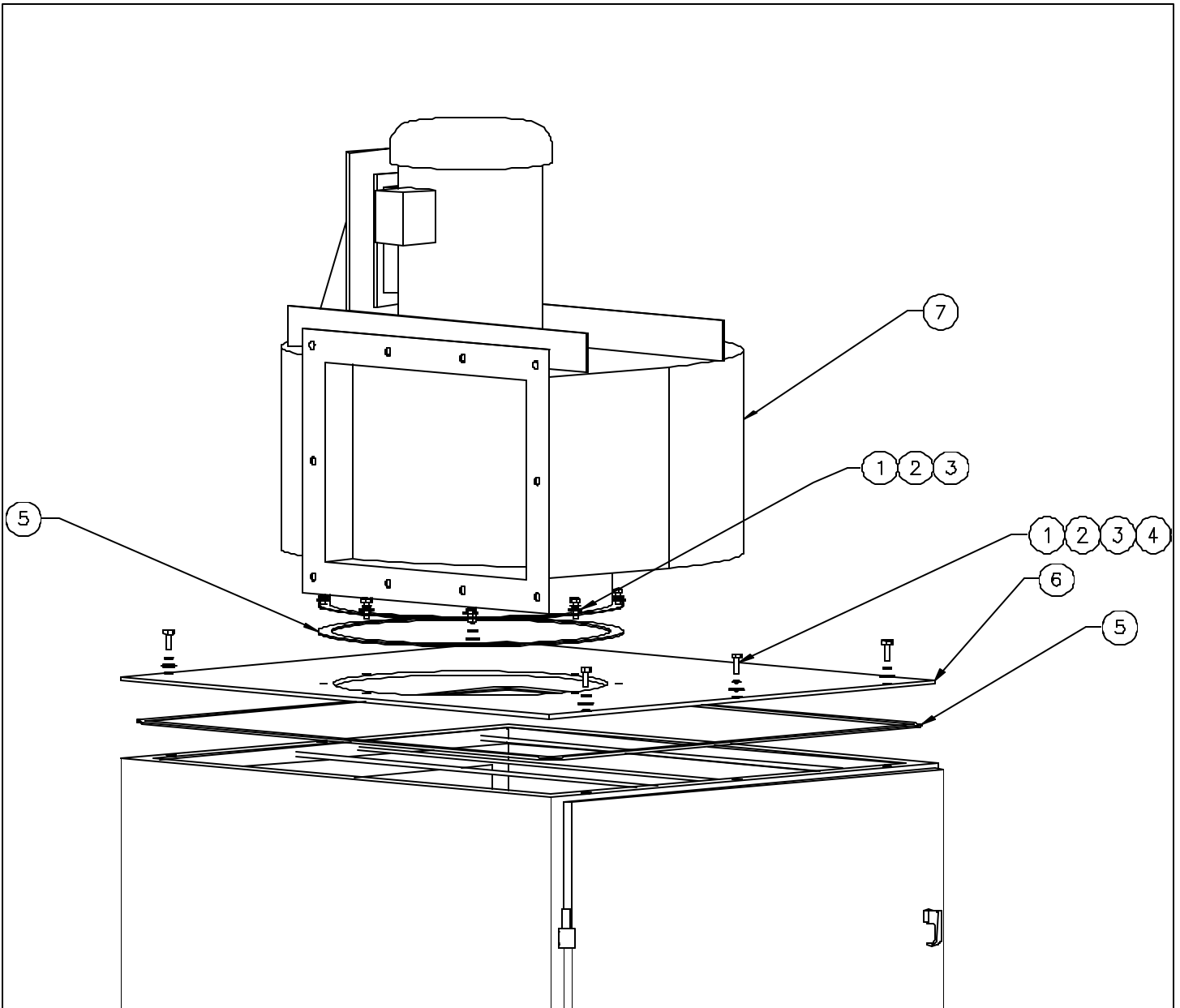

ITEM	PART NO.	DESCRIPTION
1.	P123	3/8" BOLT
2.	P142	3/8" LOCK WASHER
3.	P2206	3/8" FLAT WASHER
4.	P141	3/8" HEX NUT
5.	P3686	3/16" FOAM

ITEM	PART NO.	DESCRIPTION
6.	36798-01	ADAPTER PLATE (HDBI - 120)
	36798-02	ADAPTER PLATE (HDBI - 130)
	36798-03	ADAPTER PLATE (HDBI - 150)
	36798-04	ADAPTER PLATE (HDBI - 160)
7.	P3875	MOTOR/BLOWER 3 HP
	P3878	MOTOR/BLOWER 5 HP
	P3881	MOTOR/BLOWER 7.5 HP
	P3884	MOTOR/BLOWER 10 HP
	P3887	MOTOR/BLOWER 15 HP

OM 6000 PARTS LIST FILTER MODULE

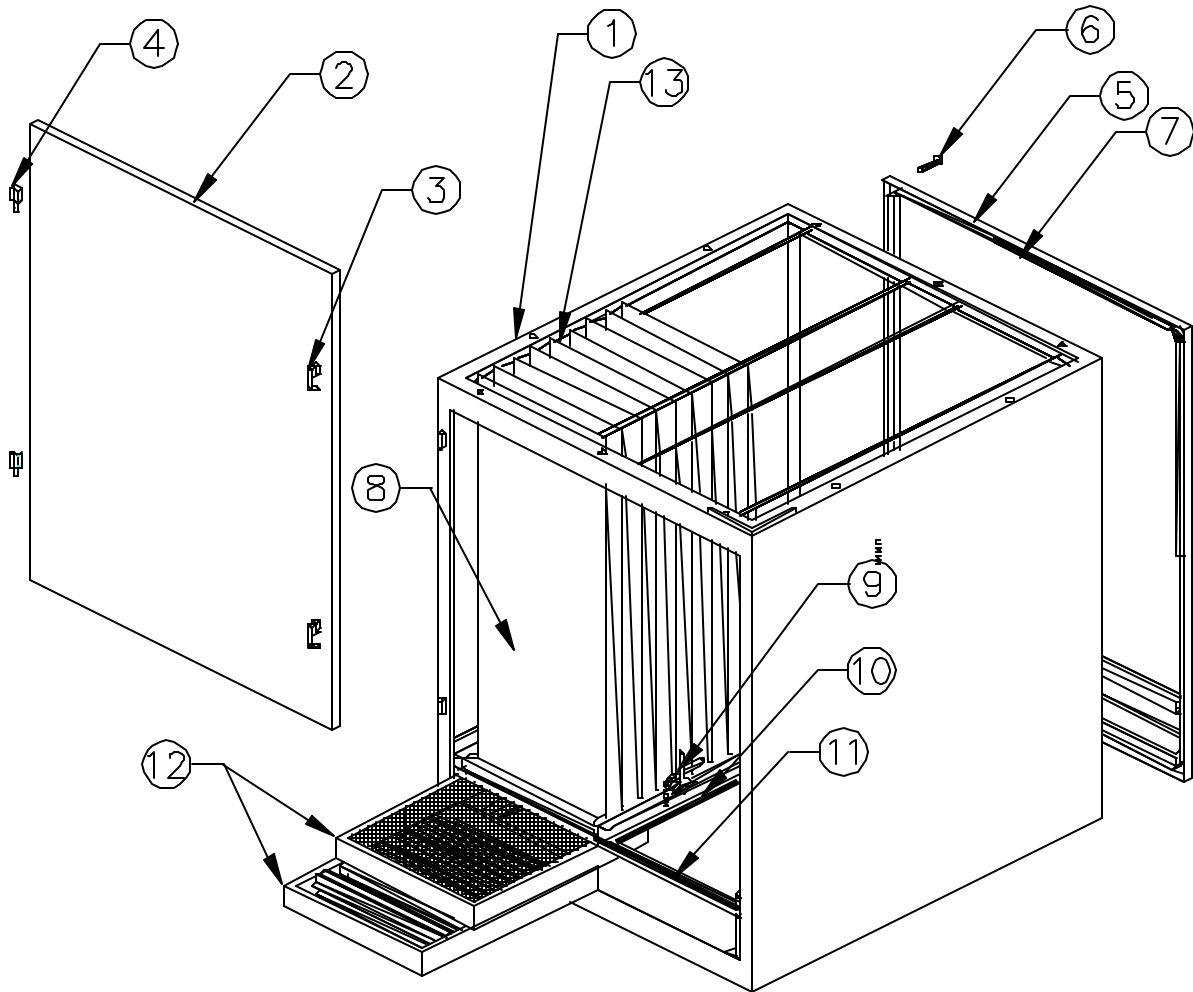

Item	Part No.	Description	Item	Part No.	Description
1.	36758-01	Cabinet Weldment	9.	33881-01	Cam
2.	36772-01	Filter Access Door Weldment	*10.	P3214	U-Channel Gasket
3.	P1372	Door Latch	*11.	P3215	Gasket w/ Lip
4.	P2835	Door Hinge	12.	P3459	2" Alum. Mesh Prefilter
5.	36773-01	Back Access Panel Weldment		P3460	2" Baffle Impinger
6.	P3236	#12 x 2" Screw		P3462	4" Pleated Prefilter
*7.	P1887	Trimseal Gasket		P3007	4" Mist-x (Chevron Style)
8.	P3463	95% Bag Filter		P3000	Maxi-Grid Panel filter
	P3464	55% Bag Filter	13.	36776-01	Filter Rod
	P3465	95% Oil Mist Bag			* Specify Length

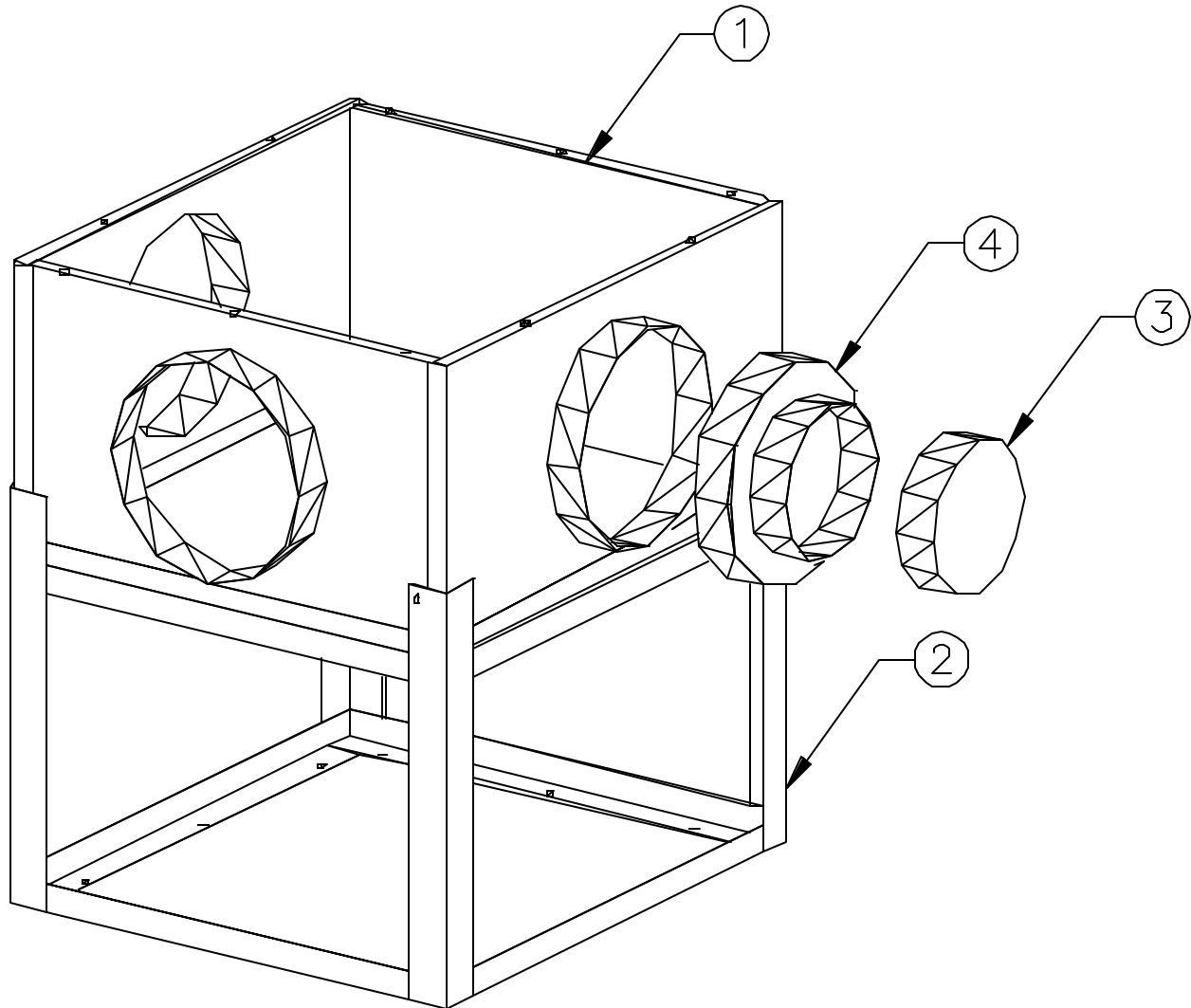

Item	Part No.	Description
1.	36750-01	Plenum Weldment with 3/16" Openings
2.	36754-01	Floor Stand (Optional)
3.	36781-01	16" Cover
	36781-02	14" Cover
	36781-03	12" Cover
	34781-04	10" Cover
4.	36784-01	16/14 Reducer
	36784-02	16/12 Reducer
	34784-03	16/10 Reducer

Installing a Magnahelic Gauge on a OM6000DD

This Kit Includes:

Qty 1	38295-02	Magnahelic Gauge Package
Qty 1	P1773	Grommet
Qty 10ft	P2806	Hose

1. Open filter section door.
2. Remove filters.
3. Using a 3/8" drill bit, drill the hole as shown in Figure A.
4. Install the grommet inside the hole.
5. Drill two 15/32" holes in the side of the unit according to the dimensions for the magnahelic barbs (See Figure C).
6. Insert the female barb threads through the hole from the inside of the unit, then screw the male barb on it from the outside.
7. On the inside of the unit, run a small hose down through the drilled hole and grommet at least seven inches. (See Figure B). The grommet should seal around the hose. (Cut the hose to the proper length and use the extra for connections outside of the unit.)
8. Slide the exposed end of the hose over one of the magnahelic barbs.
9. Using sheet-metal screws attach the magnahelic frame to the side of the unit according to the dimensions in the Figure C.
10. On the outside of the unit, attach the magnahelic gauge to the barbs using two small hoses.
11. Reinstall the filters.
12. Turn on the unit.
13. If the magnahelic gauge needle is off the scale to the left, switch the outside hoses at the magnahelic barbs.

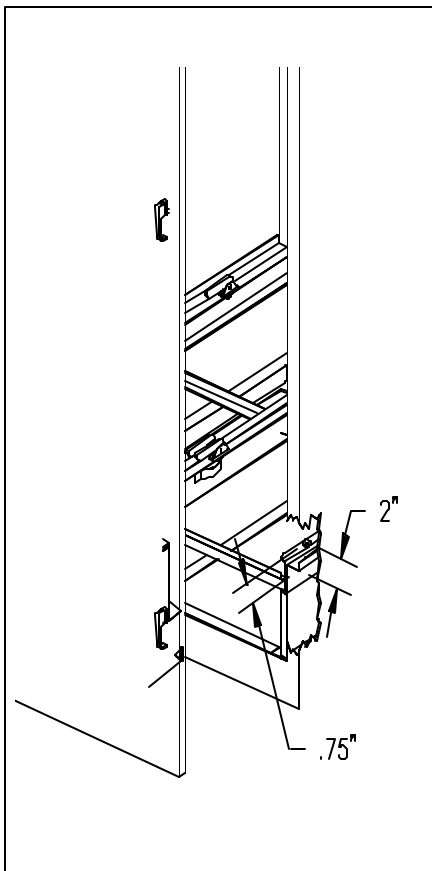

FIG. A

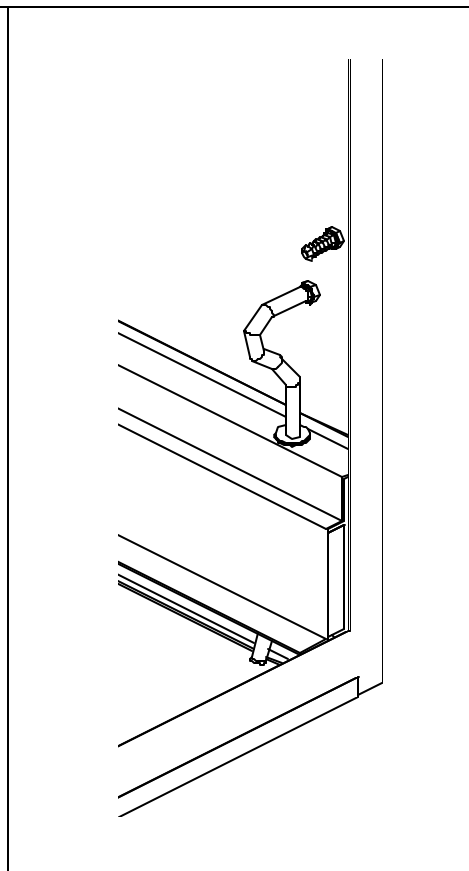

FIG. B

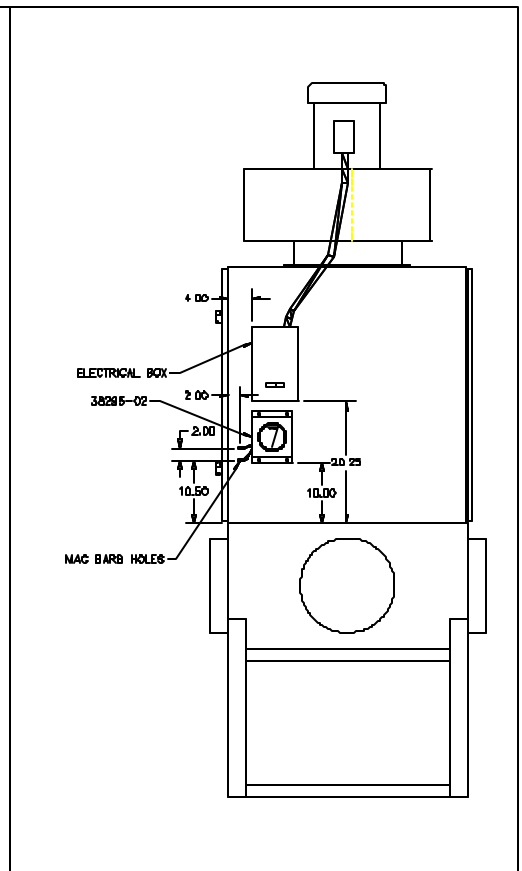

FIG. C

