

MICRO-AIR DUST COLLECTOR

Installation and Operation Manual

MODEL RP2

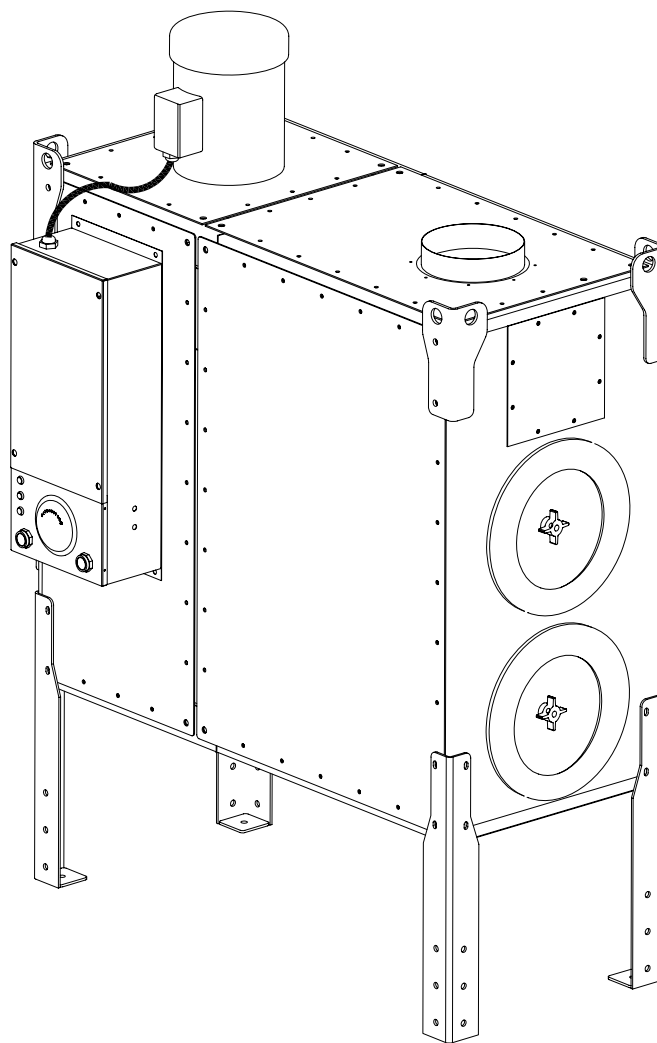

Important:

This manual contains specific cautionary statements relative to worker safety. Read this manual thoroughly and follow as directed. It is impossible to list all the hazards of dust control equipment. All persons involved with the equipment or systems should be instructed how to operate in a safe manner.

Warnings:

Many of the processes outlined in this manual will expose the installer to circuits powered by high voltage. This installation is recommended for professional electricians or MicroAir trained personnel.

All wiring must be done in accordance with applicable National, State, and local electrical code. MicroAir does not determine what is acceptable in any local jurisdiction and cannot be held responsible for wiring that does not meet local codes.

Improper installation or operation of this equipment can cause damage to equipment and / or injury to personell. The installation/operation manual must be read and followed in its entirety.

Avoid mixing combustible materials, such as buffing lint, paper, wood, aluminum, and magnesium dust, with dust generated from grinding ferrous metals due to the potential fire hazard caused by sparks in the dust collector.

Under no conditions should the persons operating the dust collector be allowed to put cigarettes or any burning object into the hood or ducting of aly dust collector system.

All users of Micro-Air Dust Collector Equipment should comply with all National and Local Fire Codes and/or other appropriate codes when determining the location and operation of dust control equipment.

When dust collectors are used to collect flammable or explosive dusts, the dust collector should be located outside the building. Also, an istaller of fire extinguisher equipment, familiar with this type of fire hazard and local fire codes, should be consulted for recommendations and installation of the proper fire extinguishing equipment. Dust collectors do not contain fire extinguishing equipment.

Explosion relief vents are required on some applications. Consult with an insurance underwriter or a NFPA Manual to determine proper vent size ratio. Vents installed on dust control equipment within a building, must be vented to

the outside to minimize changes of secondary explosion. Consult the proper authority to determine proper method of venting.

Explosion Relief Vents are not available for RP2 unit.

Specifications:

Input Voltage:

208-230/460VAC 60 Hz 3-Phase

Maximum Current:

3HP 208-230V	8.4-7.6 amps
3HP 460V	3.8 amps
5HP 208-230V	13.6-12.4 amps
5HP 460V	6.2 amps

Motor:

3HP, 3-Phase TEFC Motor, 3450 RPM
5HP, 3-Phase TEFC Motor, 3500 RPM

Cabinet Dimensions:

76" H x 28" W x 56" D

Weight:

535 lb.

Filter Area:

348 square feet

Dust Trap Capacity (Optional):

2.0 cubic feet total

Air Recuirements:

80 psi minimum / 90 psi maximum, clean dry air.

Minimum air line 3/4 inch at 80 psi maximum.

3/4" NPT Female fitting is standard for shp air attachment.

Clean, dry, compressed air at the correct pressure is required for the cleaning system to operate correctly. It is recommended that a pressure regulator and coalescing filter be installed between the copressed air source and the inlet to the dust collector.

Installation:

Inspection:

The Micro-Air Dust Collector RP2 is shipped on one skid. This skid should be inspected for any visible damage that may have occurred during shipment. Additional equipment that may be shipped separately includes:

Leg Cross Bracing Kit
Photohelic Kit
Wheel Kit

Equipment/Tools Required:

Equipment and tools needed for proper installation will include the following:

Crane or Lift Truck
Lift Straps or Chain
1/2" Socket Wrench
Pipe Wrench

Assembly of Unit:

1. Determine the location where the unit is to be installed. Be sure to allow sufficient room to access the unit for servicing and maintenance on all sides.
2. Lift the unit with a lift truck or overhead crane using the four lifting lugs located at the corners of the unit (see Figure 1).

NOTE: Each lifting strap or chain should be rated for 2000 lb. The chains located on the motor side should be 10 inches shorter than the chains on the filter side.

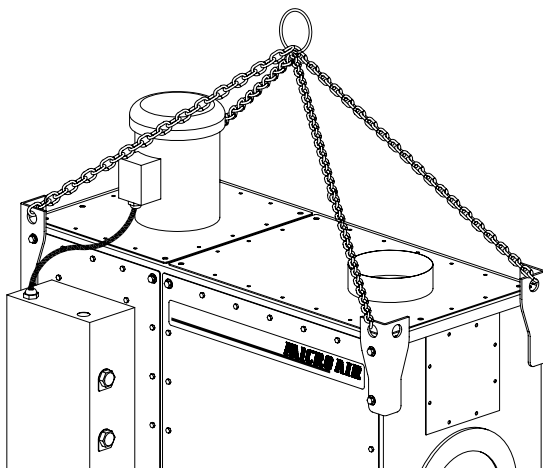

FIGURE 1

CAUTION:

THE UNIT SHOULD BE LIFTED OFF THE SKID AND SET INTO POSITION BY USING A FORK LIFT. SEVERE DAMAGE MAY RESULT FROM ANY OTHER LIFTING METHOD.

3. If the wheel kit is not included, each leg should be bolted to the ground using the 1/2" diameter hole provided in the base plate of each leg (see Figure 2).

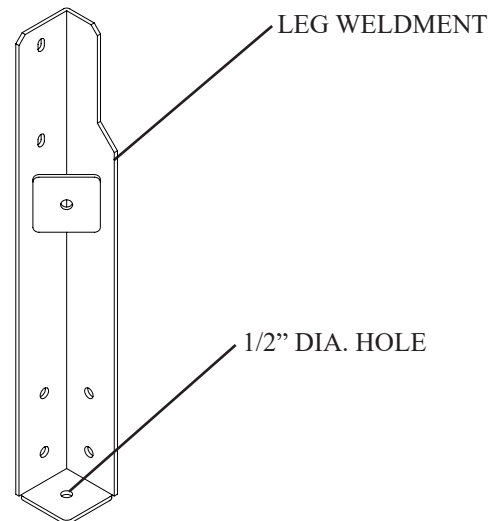

FIGURE 2

Compressed Air Installation:

The compressed air inlet for the Roto-Pulse cleaning system is at the top of the manifold assembly located on the backside of the unit (see Figure 3). A minimum of a 3/4 inch line and plant air at a pressure of 80 psi is required for proper operation of the Roto-Pulse cleaning system.

NOTE:

CLEAN, DRY, COMPRESSED AIR AT THE CORRECT PRESSURE IS REQUIRED FOR THE CLEANING SYSTEM TO OPERATE CORRECTLY. IT IS RECOMMENDED THAT A PRESSURE REGULATOR AND COALESCING FILTER BE INSTALLED BETWEEN THE COMPRESSED AIR SOURCE AND THE INLET TO THE DUST COLLECTOR.

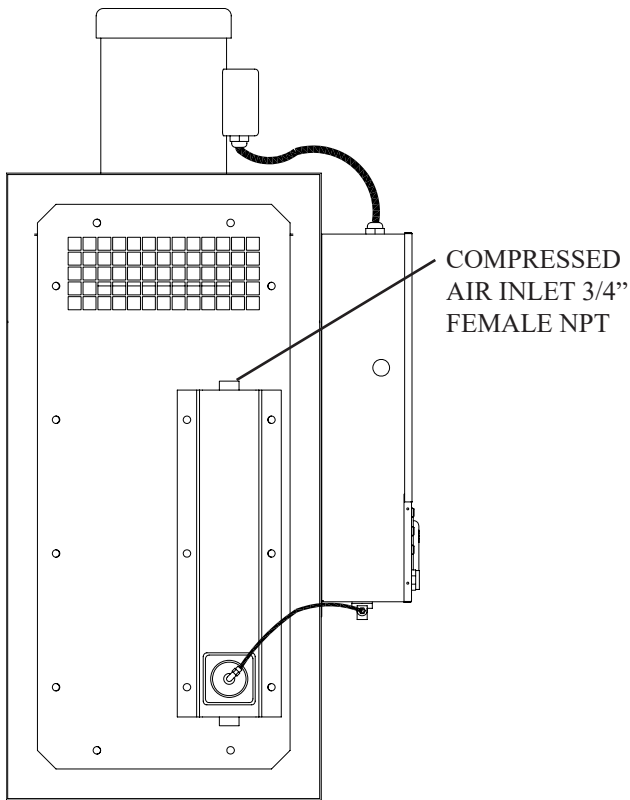

FIGURE 3

NOTE:

ALL ELECTRICAL WORK MUST BE DONE BY A QUALIFIED ELECTRICIAN ACCORDING TO LOCAL CODES.

CAUTION:

INSTALLATION CAN CAUSE EXPOSURE TO LIVE COMPONENTS. DISCONNECT ELECTRICAL POWER BEFORE PROCEEDING WITH INSTALLATION. PROPER LOCK OUT / TAG OUT PROCEDURES SHOULD BE USED.

Electrical Installation:

1. Remove the electrical box cover located on the side of the unit.
2. Make connections from your supply power to terminal L1, L2, and L3. Wire size should be rated for motor horsepower load needed for your application (see Figure 4).

NOTE: A 7/8" diameter hole is provided for conduit connection of supply power.

3. Connect the power. Momentarily turn the unit on and off with the start/stop switches. Note the rotation of the motor. Proper rotation can be viewed through the grill at the back of the unit. The proper rotation is in the clockwise direction as viewed from the top of the unit.

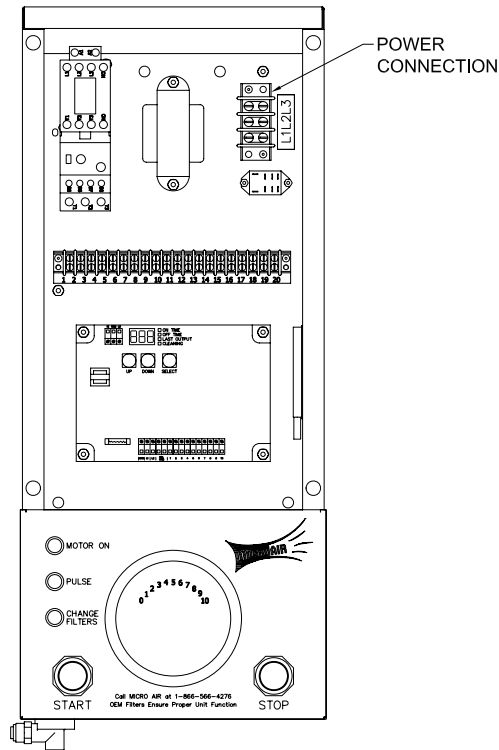

FIGURE 4

4. If motor rotation is in the proper direction the AMP draw of the motor should be checked. Correct motor AMP draw information is located on the inside of the Electrical Box Cover. If motor current is higher than rated for the motor supplied, do not continue operation. Re-check your wiring (refer to the inside of the electrical box cover) and if problems continue contact your Micro-Air Dust Collector representative for instructions.
5. Reassemble the electrical box cover onto the enclosure.

Unit Operation:

1. Turn the unit on via the start switch located on the side of the electrical box.

Note: Some particulate may pass through the cartridge filters and blower upon initial start-up. This will end once the filters have been seasoned and a powder cake has formed on the filter. If this condition continues to occur refer to the section ROTO-PULSE CLEANING TIMER ADJUSTMENTS to increase the period of time between pulses

2. Once the unit is running the Roto-Pulse cleaning system will be operationa. Operation is detected by hearing a 2-second air pulse approximately every 90 seconds. If adjustment to timing of pulses is disired refer to the section ROTO-PULSE CLEANING TIMER ADJUSTMENTS.
3. Check the After-Pulse Cleaning cycle by turning off the unit via the stop switch located on the front of the electrical box. The unit should continue to pulse every 90 seconds for a period of approximately 5 minutes. If adjustment to the after-pulse time is desired, refer to the section labeled AFTER-PULSE CLEANING.

Cartridge Cleaning Operation:

The Micro-Air Dust Collector is designed with the Roto-Pulse Cleaning System to clean the cartridge filters.

This system provides superior cleaning performance using a rotating tube with pre-drilled holes (see Figure 5). As the diaphragm valve opens, the Roto-Pulse tube rotates while air exits the holes, thus providing the cleaning of the cartridge.

1. For proper cleaning, the compressed air pressure should be regulated at 80 psi maximum.
2. During normal operatin the Roto-Pulse cleaning system is factory set to clean two (2) cartridge filters for a period of 2 seconds every 90 seconds.

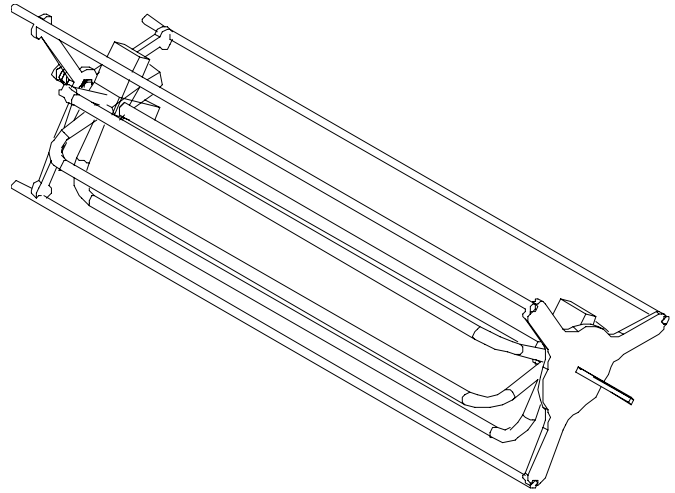

FIGURE 5

3. Once the unit is turned off, the cleaning cycle will continue for a period of five minutes. Dot not service the filters until cleaning is completed.

CAUTION:

ALLOW 15-MINUTES DOWNTIME BEFORE OPENING FILTER ACCESS DOORS. AFTER-PULSE SYSTEM IS MOMENTARILY OPERATIONAL AFTER UNIT IS TURNED OFF.

4. The Roto-Pulse cleaning operation dislodges particles from the cartridges. Particles then fall down into the collector.

NOTE: When servicing the collection system, be sure to turn the unit off.

Roto-Pulse Cleaning Timer Adjustments:

1. Turn the unit off via the stop switch located on the front of the electrical box.
2. Remove the electrical box cover.
3. The timer control board is pre-set at the factory to clean the cartridge filters every 90 seconds. This time can be adjusted from 1 second to 999 seconds. To adjust this time press the select button on the timer board until the off time LED is lit. Press the up/down buttons until the desired value is displayed. Press select to set the new value.

NOTE: Cleaning of the filters too often will decrease your level of performance. A certain level of dust cake on the filters will improve the efficiency of the filter cartridges. You should try to maintain a minimum of 1 in. w.c. of pressure differential across the filters. If you can not maintain this minimum level of differential across the filters the time between cleaning pulses should be increased until this can be achieved.

4. The timer control board is preset at the factory to have a cleaning pulse duration of 90 seconds. This can be adjusted from .05 seconds to 600 seconds. To adjust this time press the select button on the timer board until the on time LED is lit. Press the up/down buttons until the desired value is displayed. Press select to set the new value.

NOTE: While this time can be adjusted we recommend that you leave the "ON TIME" at the factory setting. If less cleaning is needed you should increase the time between pulses as a means of reducing the amount of cleaning. If more cleaning is needed you should decrease the amount of time between pulses. Beware that as the time between pulses is decreased for additional cleaning the demand for compressed air will increase.

5. Once adjustments have been made replace the electrical box cover.
6. Start the unit and observe the new pulse settings and determine if additional adjustments are necessary.

After-Pulse Cleaning Timer Adjustments:

1. The unit is equipped with an After-Pulse Cleaning Cycle. This cycle will continue to clean the cartridge filters for a period of time after the unit is turned off.
2. The length of the After-Pulse operation is preset at the factory for 300 seconds (5 minutes). This time can be adjusted from 0 seconds to 999 seconds. To adjust this time press the select button until the off time LED is lit. Press and hold the select button for 3 seconds. Press the up/down buttons until the desired value is displayed. Press select to set the new value. The After-Pulse operation can be disabled by setting the time value to zero (0) seconds.

RP2 DUST COLLECTOR

DUST COLLECTION TRAY INSTALLATION PROCEDURE

This Kit Includes:

20 ea.	P3543	Self-Tapping Screws
2 ea.	P3314	Flat Washers
2 ea.	P3559	Rubber Washers
2 ea.	P3649	4-Prong Knobs
12 ft.	P3686	3/16" x 1" Self-Adhesive Foam
86 in.	P1367	1" x 3/4" Foam (Placed at inside of Access Door)
1 ea.	38379-02	Dust Tray Weldment
2 ea.	38380-02	Dust Tray
1 ea.	38378-02	Dust Tray Access Door
1 ea.	30473-02	Access Door Handle

NOTE: Dust tray access door must be removed prior to assembly

INSTALLATION:

1. Apply self-adhesive foam to the bolt hole flange on the dust tray.
2. Align the hole pattern on the dust tray flanges with the hole pattern on the underside of the unit.
3. Attach the dust tray weldment (38379-02), using twenty (20) self-tapping screws, to the unit.
4. Slide the dust tray (38380-02) into the dust tray weldment.
5. Attach the access door to the dust tray weldment and tighten it using the provided two (2) 4-prong knobs, rubber washers, and flat washers.

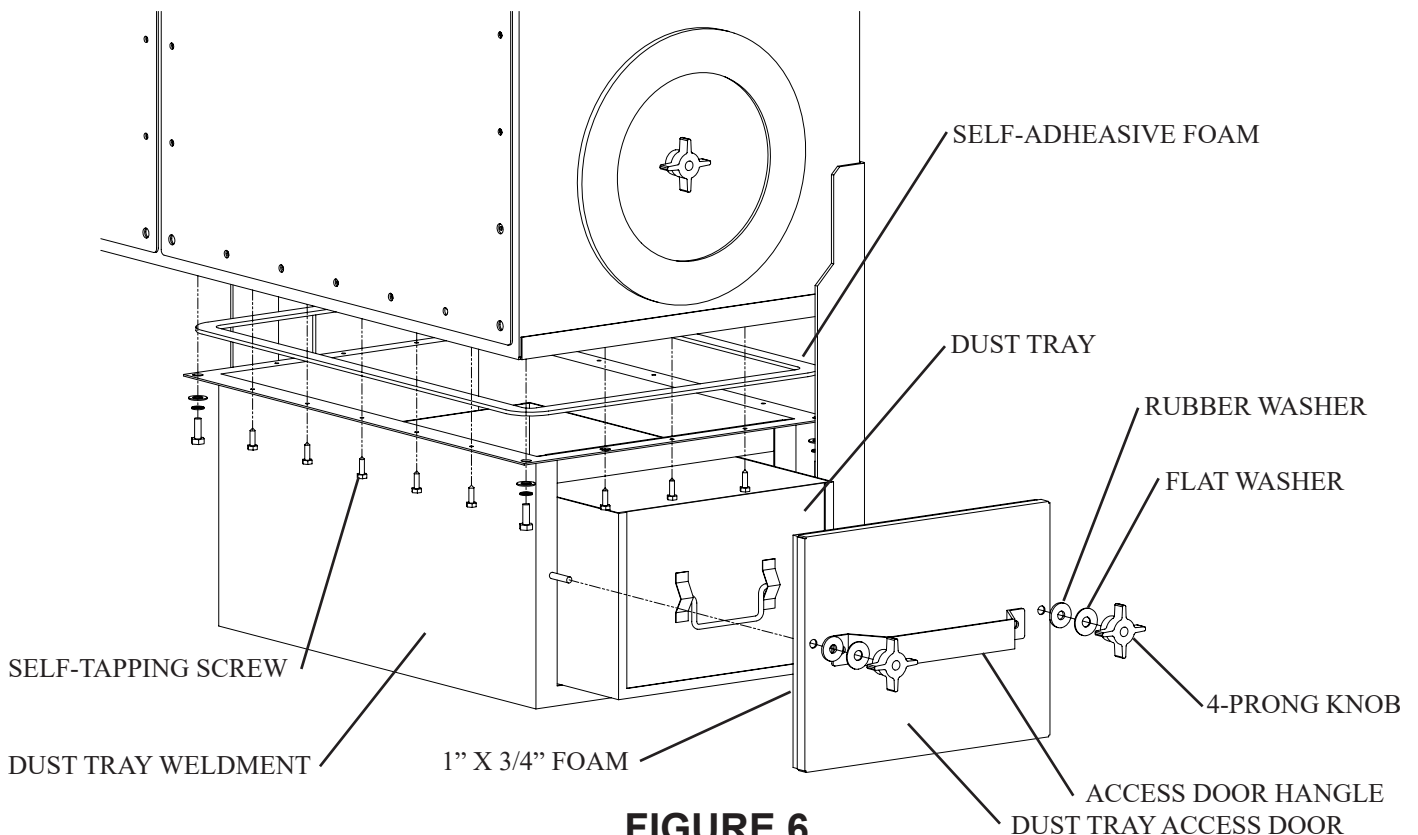

FIGURE 6

RP2 DUST COLLECTOR

LEG BRACING AND WHEEL MOUNTING INSTALLATION PROCEDURE

This Kit Includes:

8 ea.	P191	5/16" Hex Bolts	4 ea.	P3792	6" Phenolic Wheels
8 ea.	P222	5/16" Hex Nuts	4 ea.	P146	1/2" Hex Nuts
16 ea.	P233	5/16" Flat Washers	4 ea.	P147	1/2" Lock Washers
8 ea.	P249	5/16" Lock Washers	4 ea.	P2758	1/2" Flat Washers
2 ea.	38112-01	Leg Cross Braces	1 ea.	38121-01	Cross Brace support

INSTALLATION:

1. Straighten and pulmb each individual leg.
2. Bolt each end of the cross braces to the legs, attach short cross brace before installing nuts.
3. Tighten all bolts until secure.
4. To install the wheels, insert the whell stud through the hole at the bottom of leg base.
5. Tighten the wheels with the four (4) 1/2" nuts, lock washers, and washers.

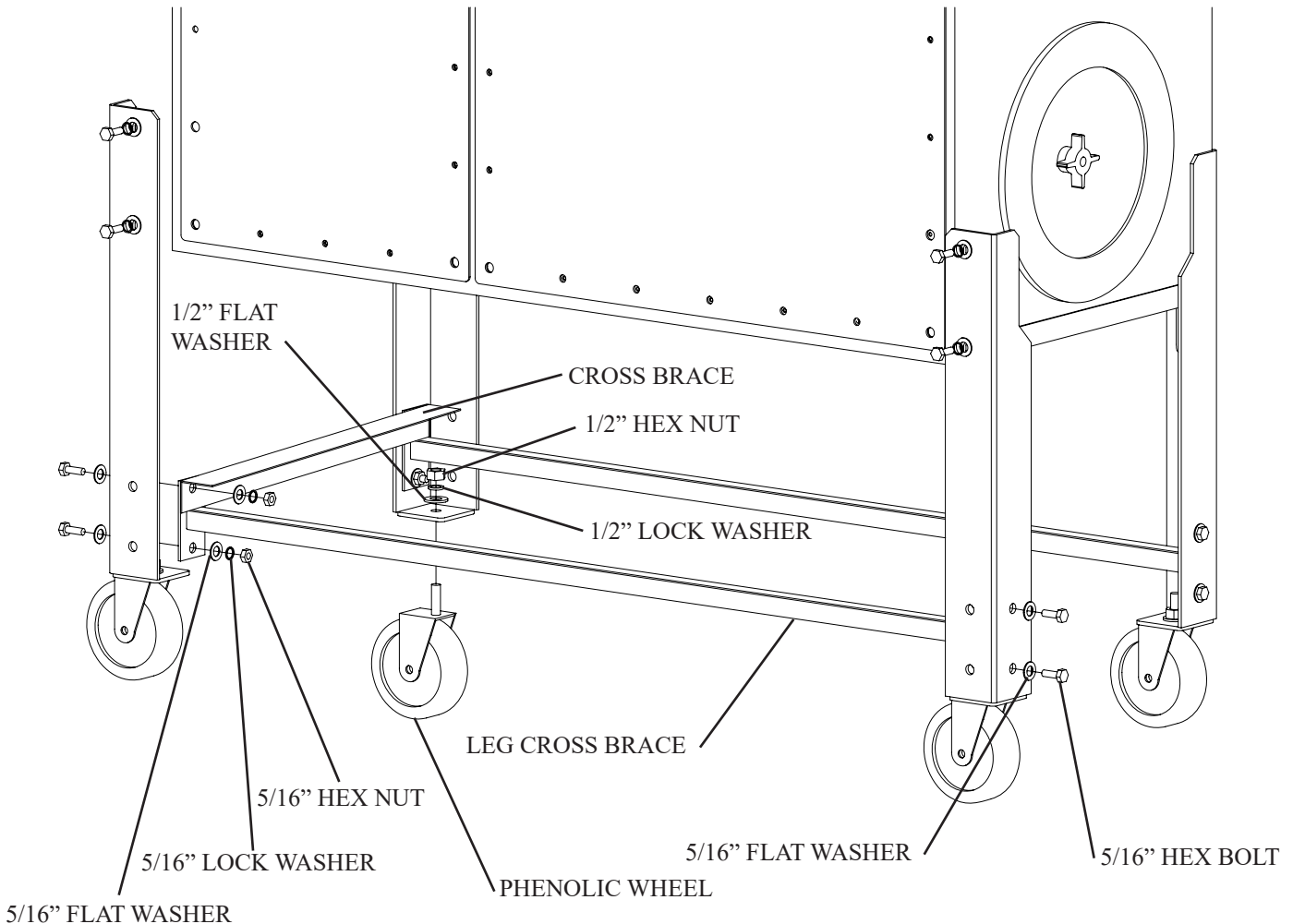

FIGURE 7

RP2 DUST COLLECTOR

AFTERMARKET MAGNEHELIC KIT INSTALLATION PROCEDURE

This Kit Includes:

1 ea.	38294-01	Magnehelic Mounting Bracket
1 ea.	P3755	0-10" w.c. Magnehelic Gauge
2 ea.	P2098	1/8" Male x 1/4" Barb Fitting
4 ea.	P3543	1/4"-14 x 1 Self-taping Screw
10 ft.	P1848	1/4" Clear Tubing

INSTALLATION:

1. Remove parts from package and inspect for any possible damage incurred during shipping.
2. Turn off dust collector and disconnect power to the unit.
3. Mount the Magnehelic Gauge into the Magnehelic Mounting Bracket and place the (2) male barb fittings in the pressure ports located on the side of the Magnehelic Gauge.
4. Also use the two pressure port plugs supplied with the Magnehelic Gauge on the two ports located on the back side of the gauge.
5. Mount the bracket using the (4) 1/4" self-taping screws.
6. Using 1/4" clear tubing (Additional length can be purchased) connect the "LOW" pressure port on the gauge to the clean air plenum and "HIGH" pressure port to the dirty air plenum.
7. Reconnect the power to the unit and start the dust collector.

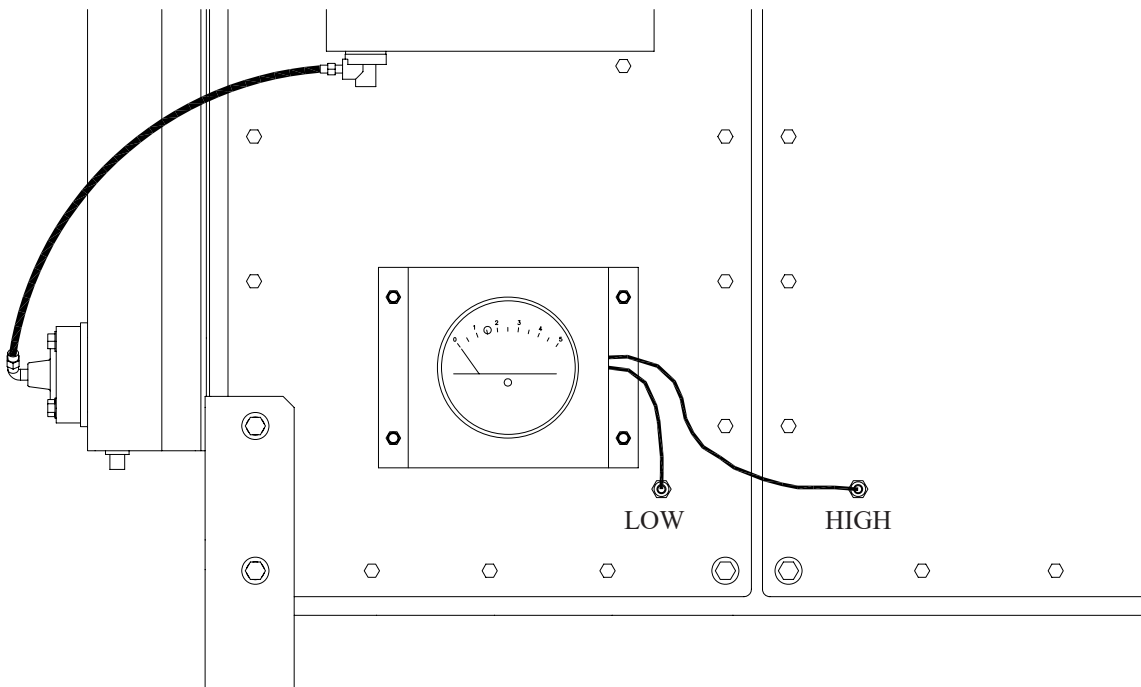

FIGURE 8

RP2 DUST COLLECTOR

PHOTOHELIC KIT INSTALLATION PROCEDURE

This Kit Includes:

1 ea.	38293-01	Photohelic Mounting Bracket
1 ea.	P3643	0-10" w.c. Photohelic Gauge
2 ea.	P2098	1/8" Male x 1/4" Barb Fitting
4 ea.	P3543	1/4"-14 x 1 Self-taping Screw
10 ft.	P1848	1/4" Clear Tubing

NOTE: When using a Photohelic on a dust collector installed outdoors, the gauge can not be mounted on the unit. It must be mounted indoors. The gauge is not rated for outdoor use.

INSTALLATION:

1. Remove parts from package and inspect for any possible damage incurred during shipping.
2. Turn off dust collector and disconnect power to the unit.
3. Remove the plastic cover on the back of Photohelic Gauge.
4. Mount the Photohelic Gauge into the Photohelic Mounting Bracket and place the (2) male barb fittings in the pressure ports located on the side of the Photohelic Gauge.
5. Remove cover from electrical box so that wiring diagram on back of cover can be used.
6. Remove the two red wires that are connected to the Timer Board Pressure Switch Input and Relay CR1.
7. Wire the Photohelic Gauge as the electrical diagram shows in Detail "A" (see page 10) using the 3/4" conduit opening on the Photohelic and the 3/4" knockout located on the electrical box. (Wire and conduit supplied by others.)
8. Replace the cover back onto the Photohelic Gauge and mount the bracket using the (4) 1/4" self-taping screws.
9. Using 1/4" clear tubing (Additional length can be purchased) connect the "LOW" pressure port on the gauge to the clean air plenum and "HIGH" pressure port to the dirty air plenum.
10. You must place the enable/disable switch located on the timer board to the "DISABLE" position. This will disable the after-pulse mode of the timer board.
11. Replace the cover on the electrical box and reconnect the power to the unit.
12. The right set point dial of the gauge should be positioned at the filter differential set point you want the Roto-pulse system to be enabled. The left should be positioned at the filter differential set point you want the Roto-pulse system disabled.

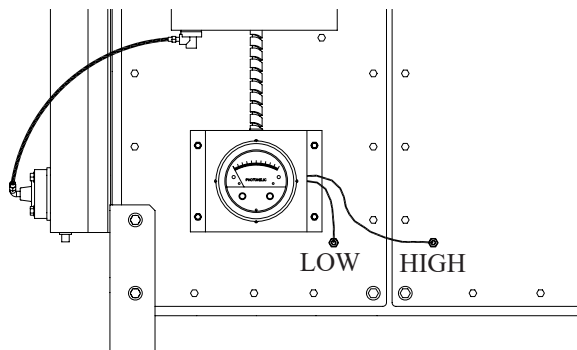

FIGURE 9

RP2 WIRING DIAGRAM

RP2

INPUT VOLTAGE (3 PH)

- 208-230 VAC.
- 380-440 VAC.
- 190-220 VAC.
- OTHER: _____ VAC.
- 460 VAC.

FREQUENCY

- 50 HZ.
- 60 HZ.

MAXIMUM CURRENT
_____ AMPS

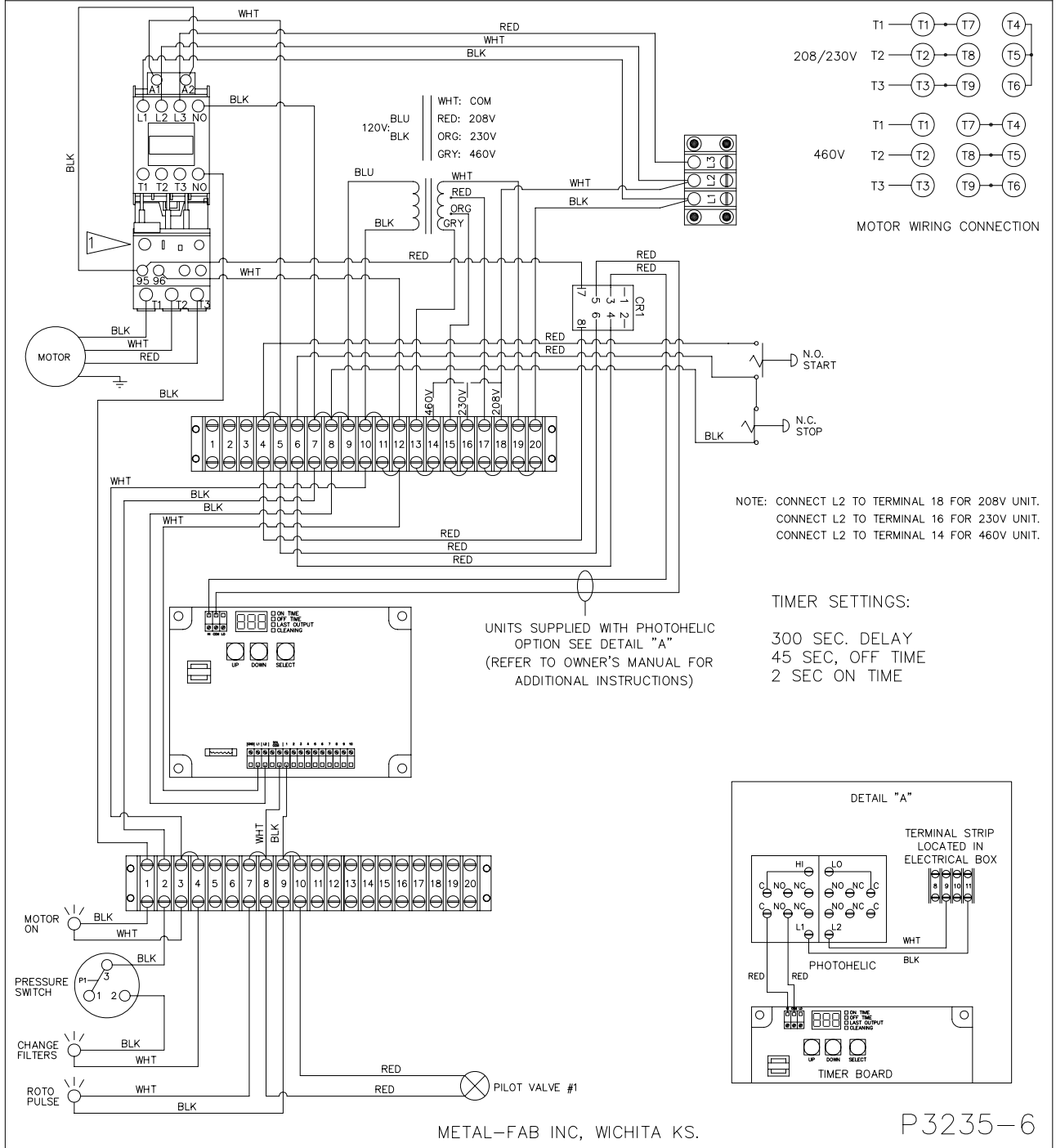

METAL-FAB INC, WICHITA KS.

P3235-6

FIGURE 10

RP2 PARTS LIST

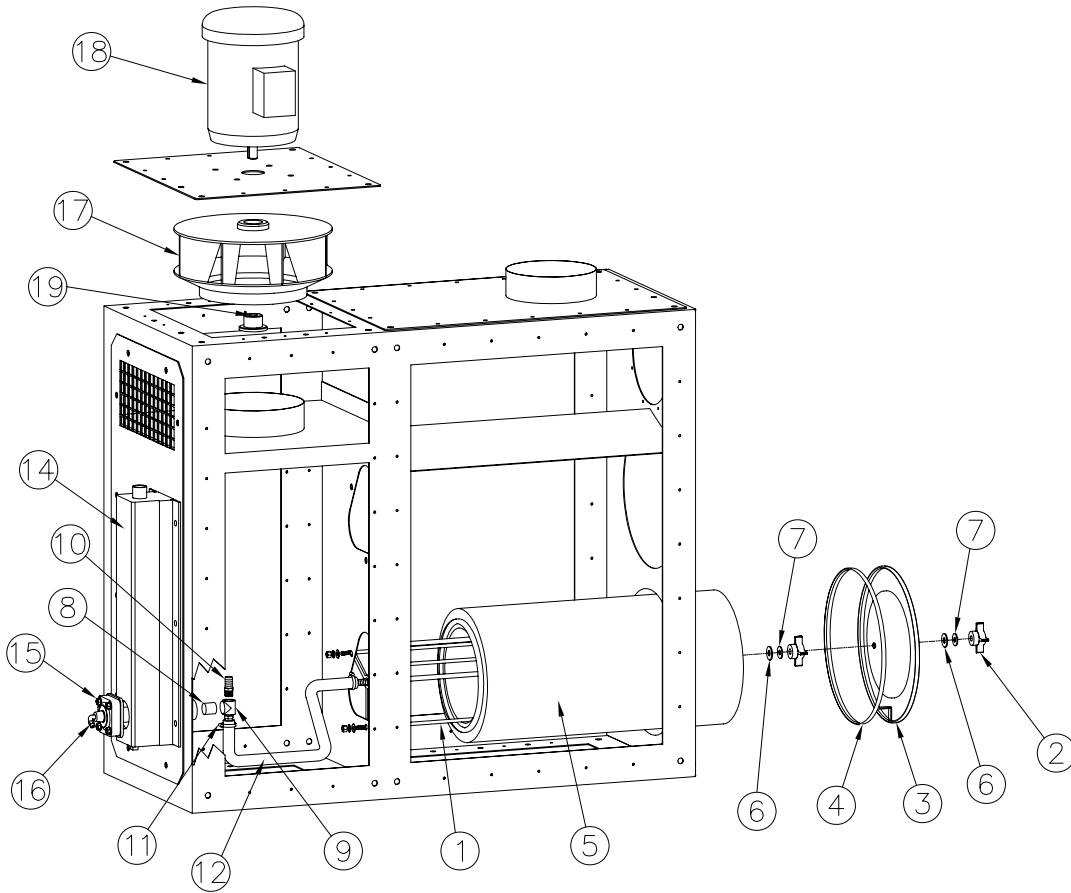

FIGURE 11

ITEM	PART NO.	DESCRIPTION
1	36713-02	Filter Support Assembly
2	P3649	4-Prong Knob
3	39034-02	End Cap Assy.
4	38342-02	Door Seal
5	P7401RM	80/20 Cellulose Cartridge Filter 174sf
	P7408HO	Treated Spun-Bond Polyester Cartridge Filter
	P7410RM	Spun-Bound Polyester Cartridge Filter
6	P3559	Rubber Washer
7	P3314	Flat Washer
8	P2099	3/4" Close Nipple
9	P3563	3/4" Galv. Tee
10	P3585	3/4" NPT x 5/8" Barb

ITEM	PART NO.	DESCRIPTION
11	P3411	1" Hose Clamp
12	P3403	5/8" Air Hose
14	38344-04	(1) Valve Manifold
15	38343-01	1" Diaphragm Valve
15A	P3098	Diaphragm Seal
	P3099	Diaphragm Kit
16	P3735	1/4" 90 deg. Presto Lock
17	P2778	3HP Impeller Wheel (CW)
	P3280	5HP Impeller Wheel (CW)
18	P2716	3HP 3-Phase 208/460V Motor
	P3097	5HP 3-Phase 208/460V Motor
19	P3451	7/8" Bushing

RP2 PARTS LIST

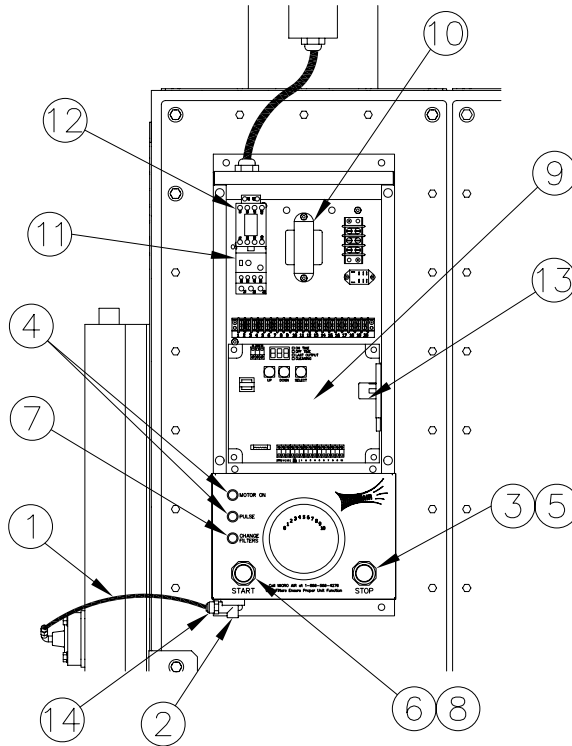

FIGURE 12

ITEM	PART NO.	DESCRIPTION
1	P3734	1/4" O.D. Air Hose
2	P3118	Pilot Valve
	39029-01	Solenoid Repair Kit
3	P3532	Stop Push Button
4	P2443	Green Lamp
5	P3529	N.C. Contact
6	P3532	Start Push Button
7	P2442	Red Lamp
8	P3528	N.O. Contact
9	P3874	Timer Board
10	P1754	Control Transformer
11	P3915	3HP 208-230/460V Overload Protector
	P3915	5HP 460V Overload Protector
	P3919	5HP 208-230V Overload Protector
12	P3910	3HP/5HP Motor Starter
13	P2441	Pressure Switch
14	P3085	1/4" Presto Lock

