



Model OM 3510

OWNER'S MANUAL

CAUTION

Read complete instructions before operating.
Please file for future reference.

MODEL OM3510 SPECIFICATIONS

Input volts:	120/230/460V, 60Hz
Max current:	16 Amps (at 120V, 1-½ HP, 1-Phase) 8 Amps (at 230V, 1-½ HP, 1-Phase) 8.4 Amps (at 230V, 3 HP, 3-Phase) 4.2 Amps (at 460V, 3 HP, 3-Phase)
Motor:	1-½ HP TEFC 3 HP TEFC
Dimensions:	81" h X 26"w X 26"l 102" h X 26"w X 26"l W/ Stand
Shipping Wt:	340lbs
Actual Wt:	310lb* *Add 35lb. per charcoal module as option

PACKAGE CONTENTS

- 1 Ea. OM 3510 Unit
- 1 Ea. Owner's Manual

PRE-OPERATING INSTRUCTIONS

1. Cut banding material and remove cardboard and plastic from unit. Remove unit from shipping skid.
2. Inspect unit for shipping damage and report any damage to freight carrier.

INSTALLATION INSTRUCTIONS

A. WALL MOUNT

1. Remove four 5/16" bolts from sides of cabinet near top and bottom of unit.
2. Use bolts removed in Step 1 to secure wall mount brackets to unit as shown in Figure 1.

FIG.1

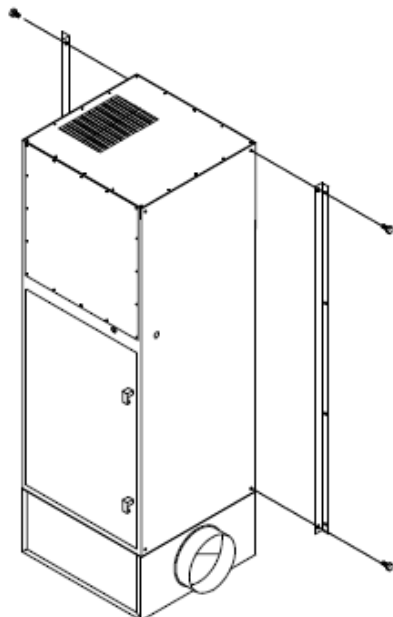

3. Locate an installation site that will provide for the following:
 - A solid structure, capable of supporting the weight of the unit.
 - Three feet of unobstructed exhaust space from the outlet of the unit.
 - Easy access to service panels and unit inlet. As near as possible to the source of oil mist unit to be captured.
4. Mark location of mounting holes on the surface to which unit is to be mounted. See **Figure 2** for hole pattern. Drill holes that are sized correctly for hole pattern in mounting hardware.

FIG.2

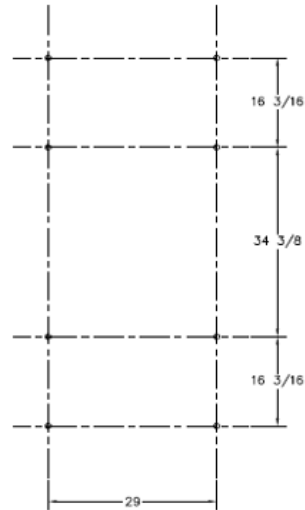

5. Position the OM 3510 wall mount bracket holes over the holes located on the structure in Step 4. Use 3/8" x 2" lag bolts or 3/8" bolts and nuts to secure OM 3510 to structure.

CAUTION: The size and weight of the OM 3510 requires two persons or mechanical means to lift and hold during mounting.

6. Connect unit to oil mist source using a duct having the same diameter as the inlet of the unit. The duct may be flexible hose or formed sheet metal. Maximum flow will be obtained with minimum bends in duct. To contain oil that will collect on the inside of the duct, the duct must be sealed. Sloping the duct toward the OM 3510 will assist flow. Use hose clamps of sheet metal screws to attach duct to unit.

NOTE: Optional hose adapters are available for connection to 6" and 8" diameter hose. Use Part No. 34096-01 for 6" dia. And Part No. 34096-02 for 8" dia. Attach adapter to plenum collar with sheet metal screws and seal with RTV sealant.

C. FLOOR MOUNT

NOTE: The optional base assembly (Part No. 38046-02) is required for floor mount installation.

3. locate an installation site on a level surface that will meet the requirements listed in Step 3 of the wall mounting instructions.
2. Set the base in place and lift the unit onto the base.

CAUTION: The size and weight of the OM 3510 requires two persons and/or mechanical means to lift and hold during mounting.

NOTE: You may want to bolt the base to the floor.

3. Connect the unit to the oil mist source as explained in Step 6 of the wall mounting instructions.

D. CEILING MOUNTING

NOTE: The optional ceiling mounting kit (Part No. 38049-02) is required for ceiling mount installation.

1. Remove the two 5/16" bolts from the side of the cabinet at the outlet end.
2. Use the bolts removed in Step 1 to secure the ceiling mount brackets to the unit as shown in **Figure 3**.

FIG.3

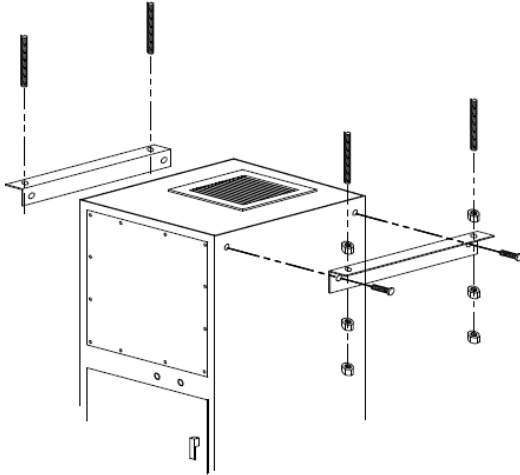

3. Locate an installation site that will meet the requirements listed in Step 3 of the wall mounting instruction.
4. Firmly secure four lengths of 3/8" threaded rod to a firm structural support. Space rods to match pattern made by holes in top of ceiling mount brackets.
5. Thread one nut onto each rod.

CAUTION: The size and weight of the OM 3510 requires two persons or mechanical means to lift and hold during mounting.

6. Raise unit up to threaded rods and insert rods through ceiling mount brackets. Thread a second nut onto each rod from below bracket.
7. Level unit by tightening nuts against ceiling mount bracket.
8. Thread a third nut onto each rod and tighten against second nut to prevent loosening of nuts due to vibration.
9. Connect the unit to the oil mist source as explained in Step 6 of the wall mounting instructions.

OIL DRAINAGE

NOTE: Should captured oil be disposed of, make sure to follow local codes.

Provision for draining oil from unit is provided for by a 1" N.P.T. pipe coupling on the bottom of the unit. Drainage can be piped to a central collection system or collected in a bucket placed under the unit. In all cases a shut-off valve or drain trap is required to prevent air bypass through the drain opening. One of the drain systems shown in **Figure 4** should be used. Drain connections and lines are not provided.

NOTE: If a shut off valve is installed in the drain system, the unit must be emptied regularly to prevent oil from overflowing into the intake duct.

FIG.4

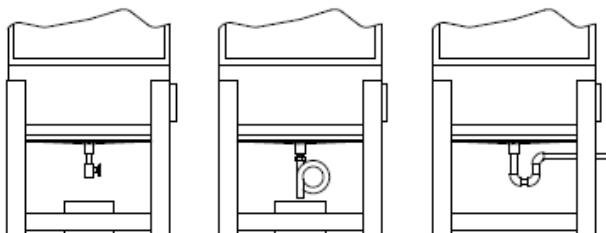

ELECTRICAL CONNECTIONS

1. Conduit electrical connections should be made by a qualified electrician, and must comply with local electrical codes.

CAUTION: Be sure that the designated circuit breaker is off until all wiring has been completed.

NOTE: It is recommended that a properly sized motor starter / protector be used in the supply circuit for 208-240V/460V/575V units. 120V units have thermally protected motors with on/off switches.

2. Make electrical connections as shown in wiring diagram to the wires protruding from the conduit on the side of the unit.
3. Check blower for proper rotation direction. Blower should rotate clockwise when viewed from the pulley end. If the blower rotates backwards, interchange two of the motor supply connections.
4. Check current draw of motor. Do not exceed AMPs specified.

PRE-OPERATION CHECKLIST

Before placing unit in service, check the following items:

- Check blower drive belt for proper tension. (Belt should deflect approximately 3/4" when firm pressure is applied midway between the pulleys.)
- Check that motor, blower, and drive pulleys are mounted securely.
- Make sure that both corners of every pocket in the filter bag is supported by the filter support rods and that filter support rods are fully engaged in their support brackets.
- Air flow direction arrows on the oil impingers / pre-filters must point toward the blower.
- Check that air intake and oil drain connections are air or oil tight.
- Make sure that all access panels, removed during installation, are replaced and the filter access door is closed.

Unit is now ready to be placed in service.

AIR FLOW ADJUSTMENT

The OM 3510 is equipped with variable diameter pulleys on the motor and blower to allow the air flow to be adjusted to the installation requirements. The pulleys are set for maximum air flow at the factory. The air flow rate can be reduced as follows:

1. Remove motor compartment access cover. Be careful to avoid tearing gasket material between door and cabinet.
2. Remove belt.
3. Loosen pulley adjustment set screw on motor pulley and screw adjustable shive away from fixed shive. Tighten set screw onto flat of fixed screw (see **Figure 5**).
4. Adjusting the motor pulley may require a size larger or smaller belt, depending on the application.
5. Replace belt and check belt tension. Proper tension should be between 1/2" and 3/4" deflection when belt is squeezed with normal pressure between fingers.
6. Replace motor compartment access cover.
7. Recheck for correct current draw of motor

NOTE: All filters and panels must be on unit and door closed for current measurements of motor.

FIG.5

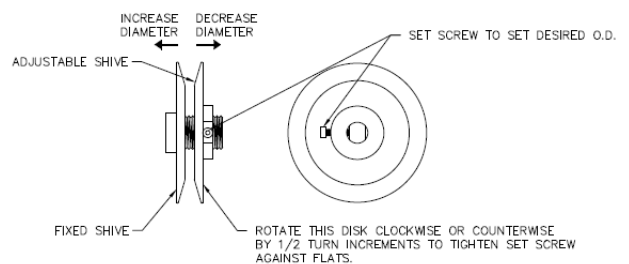

OPERATION

A. PRESSURE SWITCH ADJUSTMENTS

1. The pressure switch is preset at the factory to indicate (light on) dirty filters, but may need readjustment due to a desire for earlier or later filter changes, a different combination of filters, or because the set point shifted during shipping. The pressure switch is also orientation sensitive. To readjust the switch, remove the hole plug in the side of the unit for access to the adjustment screw. Make sure filters and pre-filters are installed in unit. Turn the unit on and place a piece of cardboard over the intake covering about 80 to 85% of the intake area. On a 3-inlet system, cover entirely two inlets and a little more than half of the area of the third inlet. With a standard screw-driver, turn the adjustment screw clockwise until the light goes off, or counterclockwise until the light comes on.
2. For more time between filter changes (less air flow), cover slightly more of the opening, and for less time between filter changes (more air flow), cover less of the opening.

B. GENERAL MAINTENANCE

1. Occasionally check the condition of the drive belt for tightness and wear.
2. Check the blower bearings for unusual wear and the blower wheel for debris and dirt. Clean when necessary.
3. Check the wiring for loose connections or cracked insulation.
4. No lubrication is required for the motor because it is a permanent pre-lube design. Excessive dirt / oil should be periodically removed.
5. Make sure oil is draining easily through drain pipe.

C. CHANGING FILTER

CAUTION: Always make sure that the unit is turned off before changing filters or servicing the unit.

3. The OM 3510 is equipped with a filter change light, or (optional) Magnahelic Gauge, which indicates when a filter needs to be replaced. If the differential pressure has been set properly, the light, or gauge signals the need for examination of the filters.
4. When the light comes on, or gauge reads high differential pressure, turn the unit off and remove the impinger and mesh pre-filter from the unit. Wash these pre-filters in a detergent solution to remove dirt and oil residue.
5. Rinse the pre-filters thoroughly with water, shake dry and replace in the unit with airflow direction pointing to the blower (replace pleated pre-filters if in use).
6. If the filter change light fails to go out, or the gauge continues to read high differential pressure, after replacing the pre-filter, then the oil bag filter may also need to be replaced.
7. Visually inspect the bag filter. If the pockets are loaded with oil and dirt, then remove the filter from the channel and insert a new filter.
8. Start the unit. The filter change light should be off, or the gauge reads low differential pressure and the unit should be operating properly.

INSTRUCTIONS FOR SIDE DISCHARGE BLOWER EXHAUST ON OM3510

CAUTION: Read instructions completely before making changes.

1. The OM 3510 motor / blower module can be rotated so that exhaust air exits from the side of the unit. Before rotating motor / blower module be sure that all input power is disconnected and unit is turned off.
2. Remove motor access door and exhaust grille.

NOTE: Care is required when removing the panel to protect the blower outlet gasket.

3. Remove 5/16" hex bolts and washers that secure motor / blower module to filter module.
4. Rotate motor / blower module 90° as shown in **figure 6**.
5. Using 5/16" hex bolts and washers re-secure motor / blower module with filter module.

CAUTION: Due to relocation of internal components, some wiring may be loose. Be sure to retain wires so they will not become loose in air stream of blower inlet.

6. Reinstall motor access door and exhaust grille.

NOTE: Care is required to protect blower outlet gasket.

7. Reconnect input power and turn unit on. Check for proper air flow and blower rotations.

FIG.6

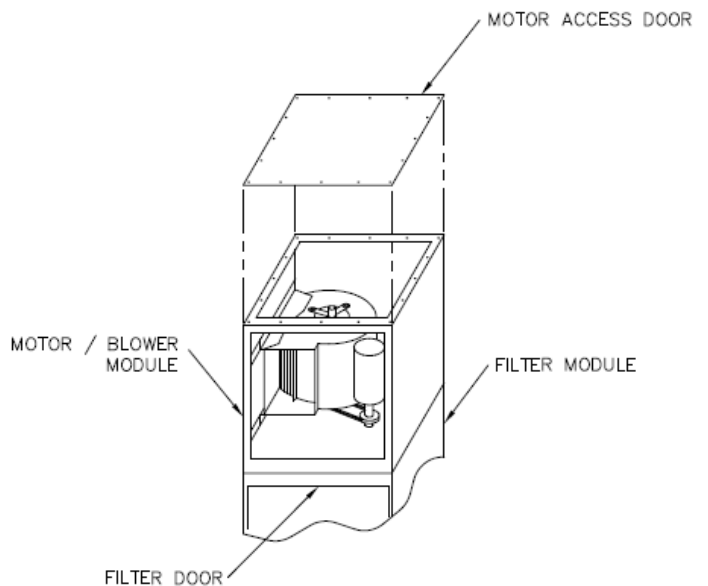

UNITS WITH HEPA OR CHARCOAL OPTIONS FOR OM3510

1. On units with optional HEPA or charcoal filters, an adjustable filter track kit is used to complete the seal of these filters to the filter stop (see **figures 7 & 8**). If the unit was ordered with either a HEPA or charcoal filter, this adjustable filter track kit was included with the unit. If a HEPA or charcoal filter is ordered as an after-market item, the adjustable filter track kit should be ordered as well. Order Part No. 38036-01.
2. Each filter track kit is supplied with:
 - (1) 1pc. Filter track
 - (2) 2pc. Supports
 - (3) 1pc. Handle
 - (4) 4pc. Retaining brackets
 - (5) 1pc. Door stop bracket
 - (6) 3pc. Horizontal support
 - (7) 16pc. #8-32 self tapping hex screws.

HEPA OR CHARCOAL AS SECOND MAIN FILTER

1. Place supports (2) in cabinet at a dimension of 13 ¼" and secure with self tapping screw.
2. Place track (1) in cabinet so it rests upon supports and ½" diameter pin is located behind brackets on supports.
3. Place handle (3) on supports so that it rests in notches.
4. Lock ½" diameter rods on handle and track in place with brackets (4) and self tapping screws.
5. Place handle stop bracket (5) at a dimension of 15 ½" and secure with self tapping screws. This is to keep handle from rotating past 90° and allowing filter to loosen.
6. Horizontal support (6) is not used in this case.

FIG.7

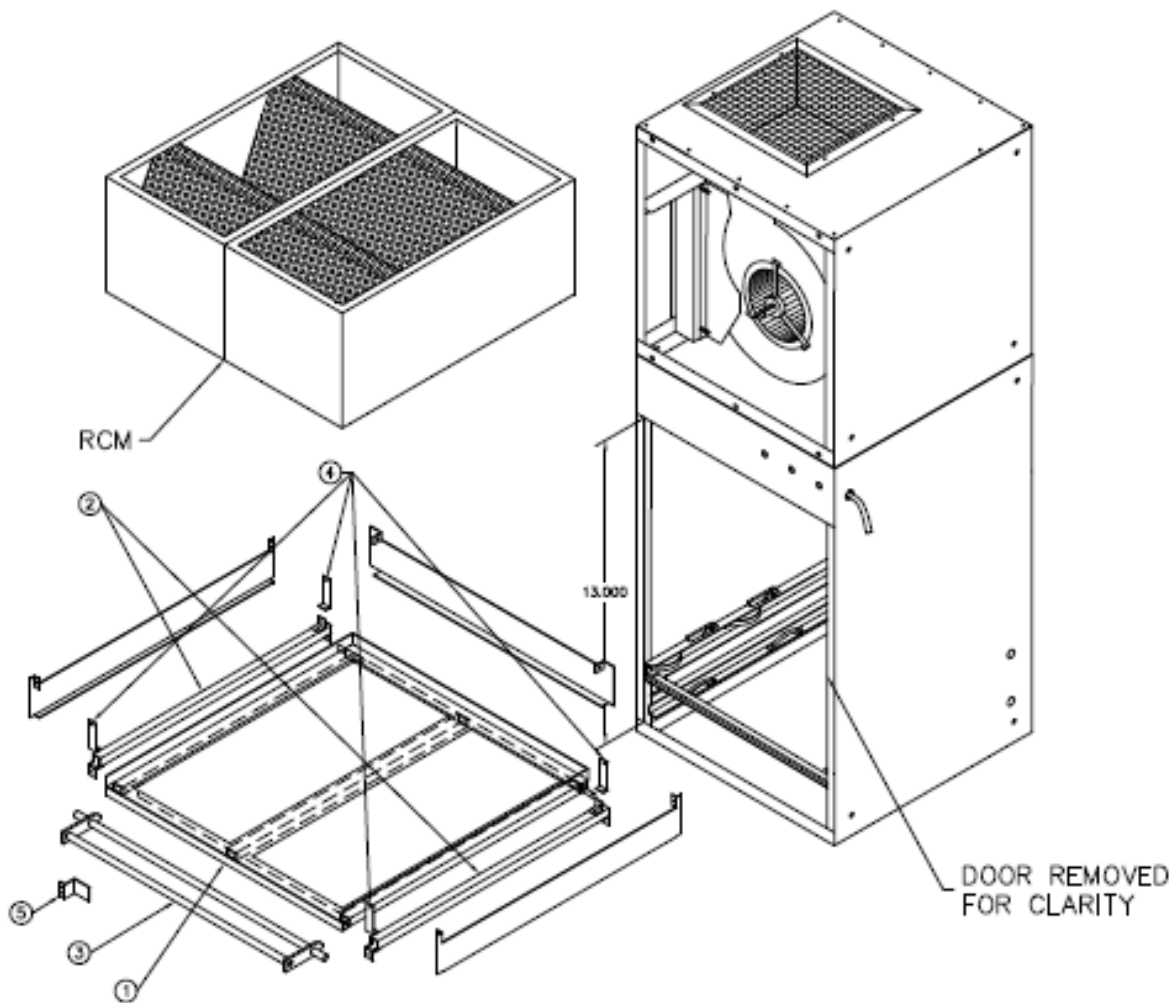

HEPA OR CHARCOAL AS FIRST AND SECOND MAIN FILTERS

1. Place supports (2) in cabinet at a dimension of $24 \frac{15}{16}$ " and secure with self tapping screws.
2. Place track (1) in cabinet so it rests upon supports and $\frac{1}{2}$ " diameter pin is located behind brackets on supports.
3. Place handle (3) on supports so that it rests in notches.
4. Lock $\frac{1}{2}$ " diameter rods on handle and track in place with brackets (4) and self tapping screws.
5. Place handle stop bracket (5) at dimension of 27" and secure with self tapping screws. This is to keep handle from rotating past 90° and allowing filter to loosen.
6. Place Horizontal supports (6) 2pc. on sides of cabinet at a dimension of 10" and (6) 1pc. on rear of cabinet at 5" and secure with self tapping screws.

FIG.8

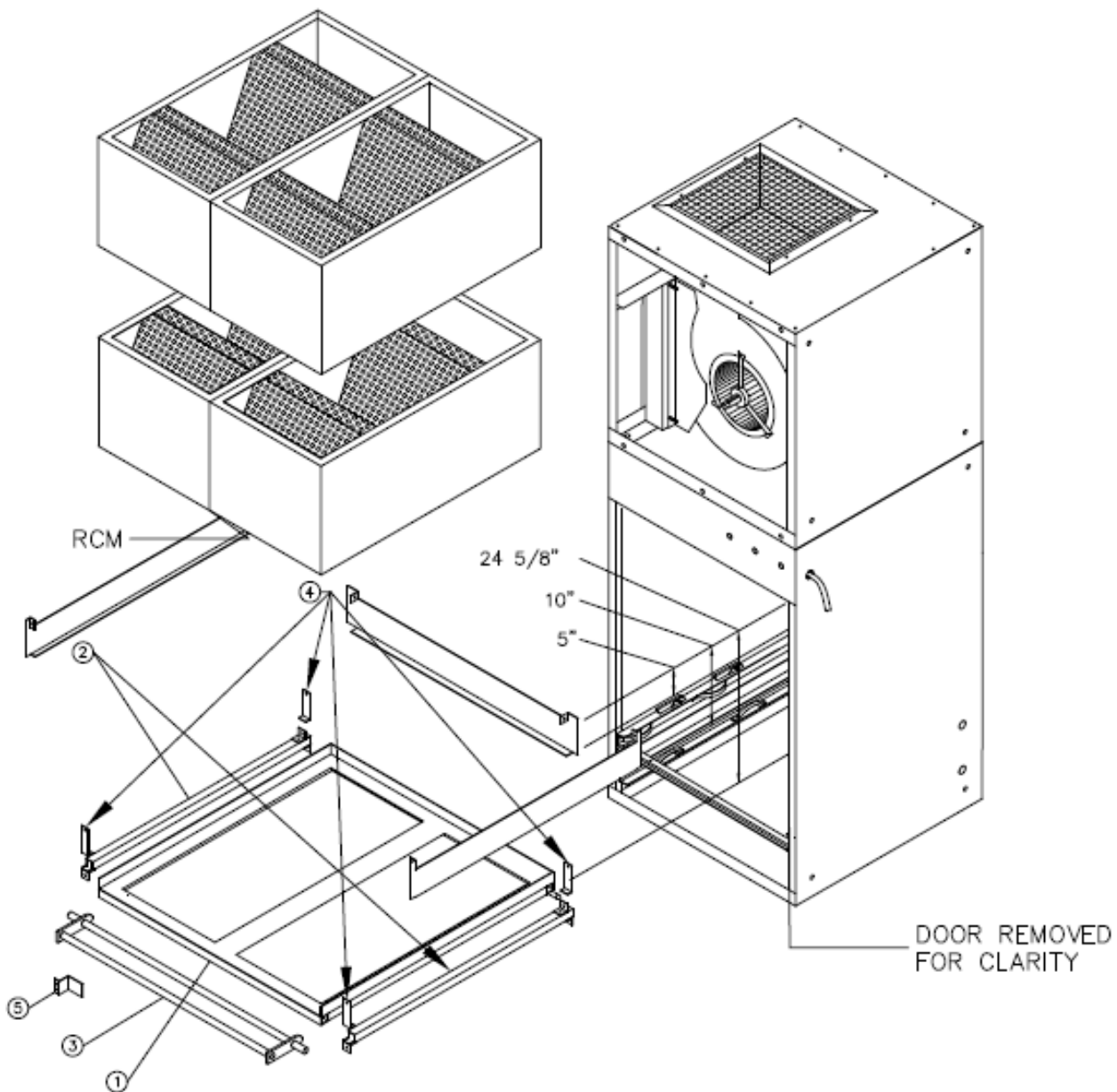

FILLING OF RCM MODULES

1. Remove bulk charcoal or purasorb from shipping carton by removing plastic bags within carton.
2. Set module on level surface. Remove fill cover by removing six 10-32 phillip head screws, that secure cover. Set cover aside (see **figure 9**).
3. Open the plastic bag by removing the tape, holding close. Pour the material from the plastic bag into the module through the slots. It may be necessary to slightly shake the module to assure an even fill. Excess material may be saved by resealing the plastic bag.

NOTE: Slow pouring will minimize dust that will be present during pouring.

4. After filling module, discard plastic bag and reinstall fill cover removed in step 2.

NOTE: The OM 3510 requires two modules when used as a second main filter and four modules when used as a first and second main filter.

5. With Filter track in place and handle pulled out away from cabinet load RCM / HEPA modules into track.

NOTE: Make sure modules are seated properly into track and stacked evenly.

6. With filters in place rotate handle 90° and lock filter modules in place.

FIG.9

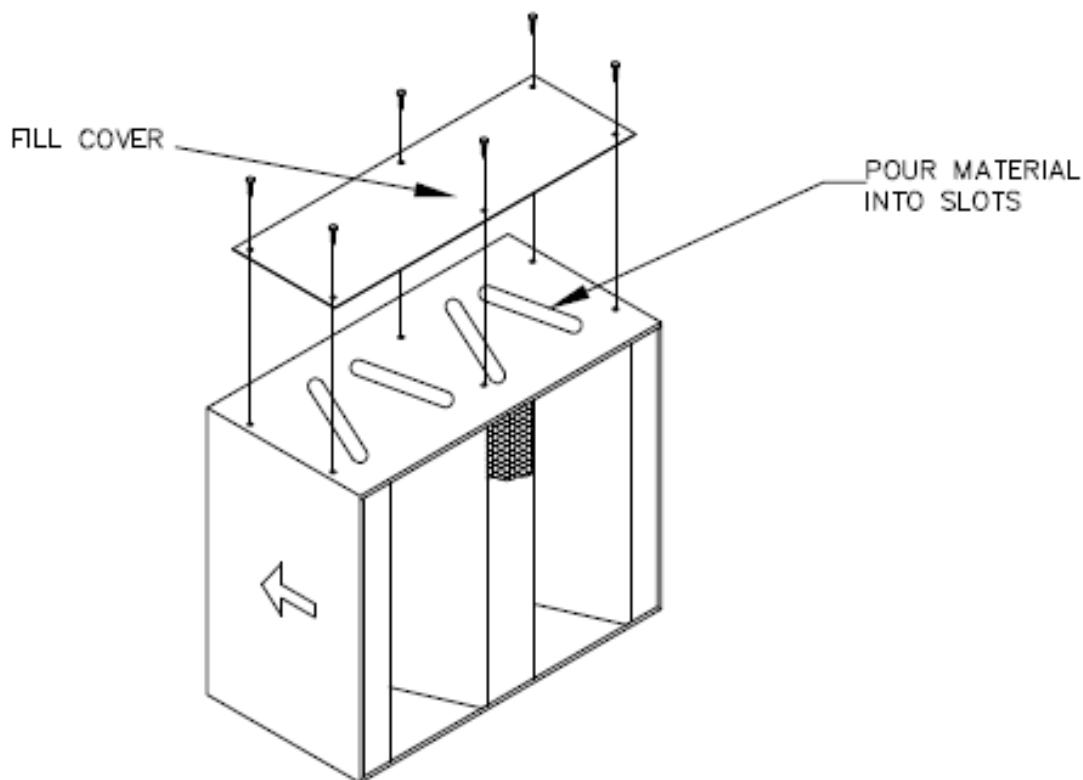

OPTIONAL SILENCER INSTALLTION

1. Remove Exhaust Grille from unit as shown in **Figure 10**.
2. Slide Silencer over Blower Assembly.
3. Align holes from Silencer with those located on sides of the Blower Assembly.
4. Attach Silencer to Blower Assembly using 3/8" bolt, lockwasher, & flat washer.
5. Center Exhaust Grille over hole in Silencer & attach using 8-32 self tapping machine screws.

FIG. 10

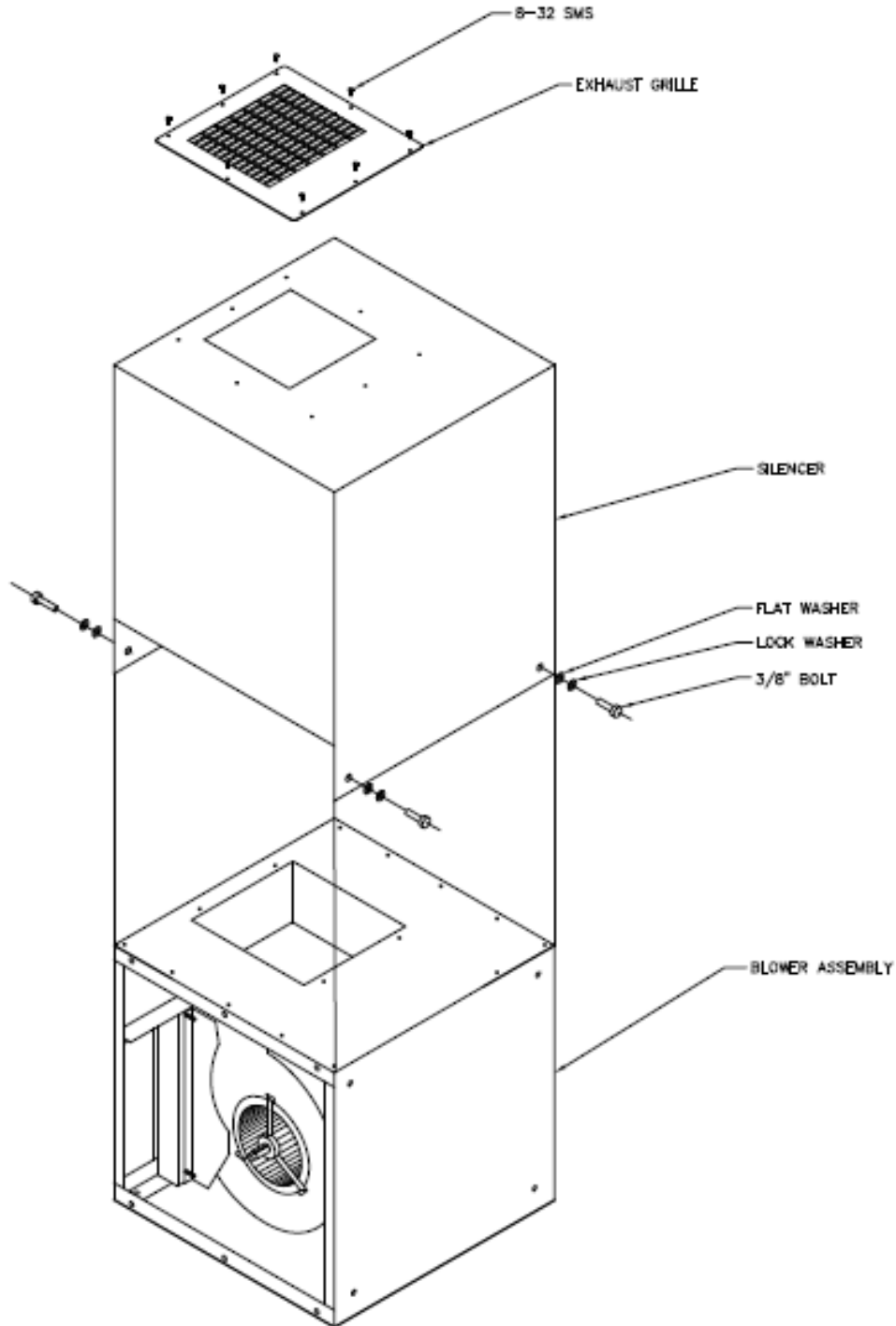

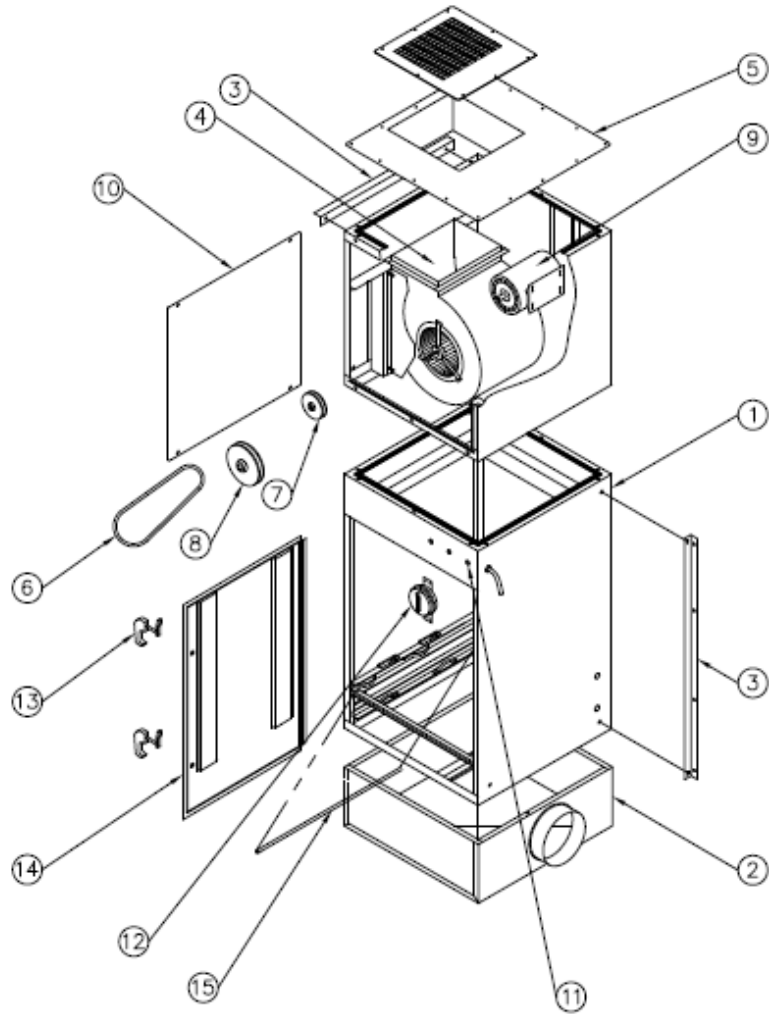

ITEM	PART NO.	DESCRIPTION	ITEM	PART NO.	DESCRIPTION	ITEM	PART NO.	DESCRIPTION
1.	38071-01	Cabinet Weldment	8.	P1710	4.95" Blower Pulley	NOT SHOWN	38046-01	Optional Floor Stand
2.	38024-01	Inlet Plenum		P1504	5.45" Blower Pulley	NOT SHOWN	38050-01	Silencer
3.	38049-01	Wall Bracket (2 ea. required)		P1974	6.25" Blower Pulley	NOT SHOWN	33740-00	RCM Module
	38049-02	Ceiling Bracket (2 ea. required)		P3218	8.00" Blower Pulley	NOT SHOWN	38036-01	Filter Track
4.	P3498	Blower (Standard)		P3270	9.75" Blower Pulley			
5.	38010-01	Blower Access Panel	9.	P3545	1-1/2 HP, 120V, 1-Phase	NOT SHOWN	P1411	Pleated Pre-Filter 4"
6.	P1495	42" Belt		P3495	3 HP, 230/460V, 3-Phase	NOT SHOWN	P1439	55% Long Bag
	P3207	43" Belt	NOT SHOWN	30251-01	Motor Mount Bracket for P3495	NOT SHOWN	P1442	95% Long Bag
	P3550	49" Belt	10.	38011-02	Motor Access Panel	NOT SHOWN	P1455	95% HEPA Filter
	P7135	51" Belt	11.	P1429	Light (120V)	NOT SHOWN	P1460	95% short Bag
7.	P2105	1-1/2HP, Var. Pitch Dia. Motor Pulley		P1481	Light (208-230V, 460V, 575V)	NOT SHOWN	P1461	Pleated Pre-Filter
	P3578	3HP, Var. Pitch Dia. Motor Pulley	12.	P3505	Pressure Switch	NOT SHOWN	P1475	Aluminum Mesh Pre-Filter
	P3986	3HP, 7.75" Motor Pulley	13.	P1372	Door Latch (2 ea. required)	NOT SHOWN	P1799	Baffle Impinger
			14.	38022-01	Filter Door	NOT SHOWN	P2101	99.97% HEPA Filter
			15.	P3214	Gasket Material (Specify Length)	NOT SHOWN	P2179	95% Oil Mist Bag
			NOT SHOWN	P2250	Magnahelic Gauge	NOT SHOWN	P2817	95% Short Oil Mist Bag
						NOT SHOWN	P3002	Max Grid Panel Filter
						NOT SHOWN	P3008	4" Mist-xfilter (Chevron)

OM 3510 Wiring Diagram

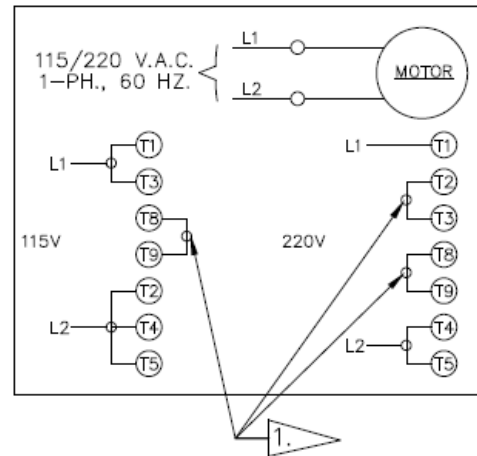
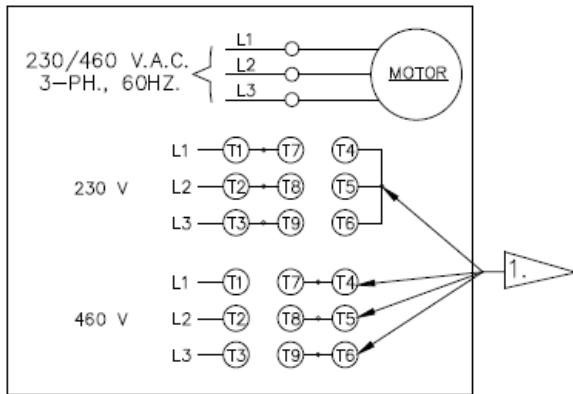
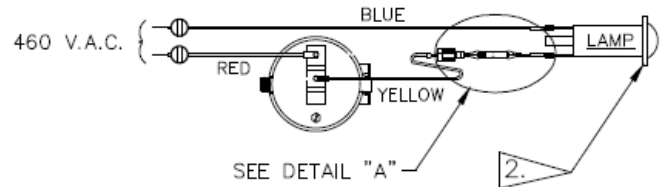
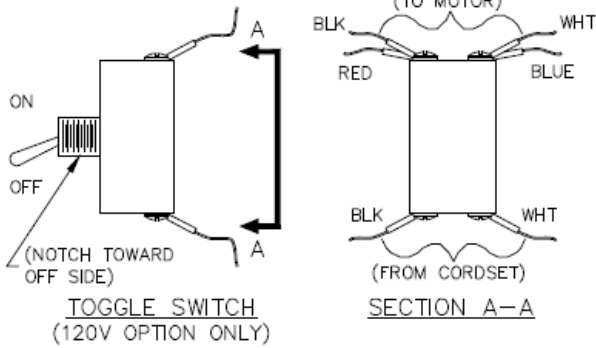
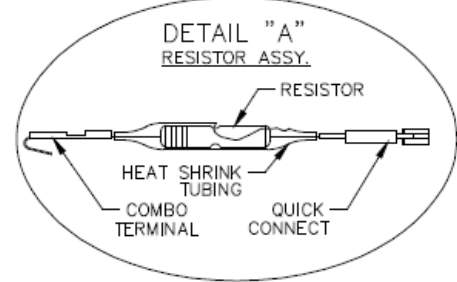
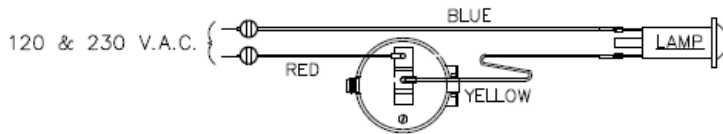

- 1. NO CONNECTION TO SUPPLY VOLTAGE.
- 2. P1429 LAMP NEEDED FOR 115 V.A.C. UNIT.
P1481 LAMP NEEDED FOR 230/460 V.A.C. UNIT.

IMPORTANT: UPON COMPLETION OF INSTALLATION, CHECK BLOWER FOR PROPER FAN ROTATION. IF ROTATION IS BACKWARDS EXCHANGE SUPPLY CONNECTIONS L1 & L2.

CAUTION: IMPROPER ROTATION OF BLOWER CAN RESULT IN DAMAGE TO BLOWER BEARINGS.

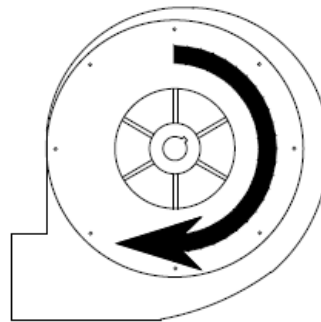

FAN ROTATION

IF REPLACEMENT IS REQUIRED, CHECK ALL WIRING CONNECTIONS AGAINST WIRING DIAGRAM FURNISHED WITH UNIT TO INSURE PROPER OPERATION, APPROPRIATE FOR DESIRED INPUT VOLTAGE.

METAL-FAB, INC.

WICHITA, KANSAS USA

FIG. 12

TROUBLESHOOTING CHART

CAUTION:

Before disassembling the unit or doing any inspection of the parts, make certain that the power has been cut off and the blower has come to a complete stop. Never run the unit with the access door open or removed.

Problem	Possible Cause	Remedy
Unit Fails to Start	Dead Power Line Blown Fuse Loose Wire in Terminal Box Burned Out Motor	Check the Circuit and Switch Replace Fuse Reconnect Wire Replace Motor
Unit Runs Slowly or Inadequate Capture Velocity	Wired for Wrong Voltage or Improper Rotation Dirty Filters Obstruction in Hose/Arm Assembly Pulleys Set For Static	Check Input Voltage Check Wiring Diagram Service Filters (See Changing Filters Section) Reach into Hood and Remove Obstruction Adjust or Change Pulleys
Vibration	Loose Mounting Bolts Foreign Objects in Blower Dirty Disposable Filters Obstruction in Hose/Arm Assembly	Tighten Bolts Remove Access Door and Remove Objects Service Filters Reach into Hood and Remove Obstruction
Unit tripping Breaker	Current Draw of Motor Too High	Adjust or Change Pulleys



Products of Metal_Fab, Inc.
P.O. Box 1138 • Wichita, Ks 67201
(866) 566-4276 • FAX (316) 943-2717