

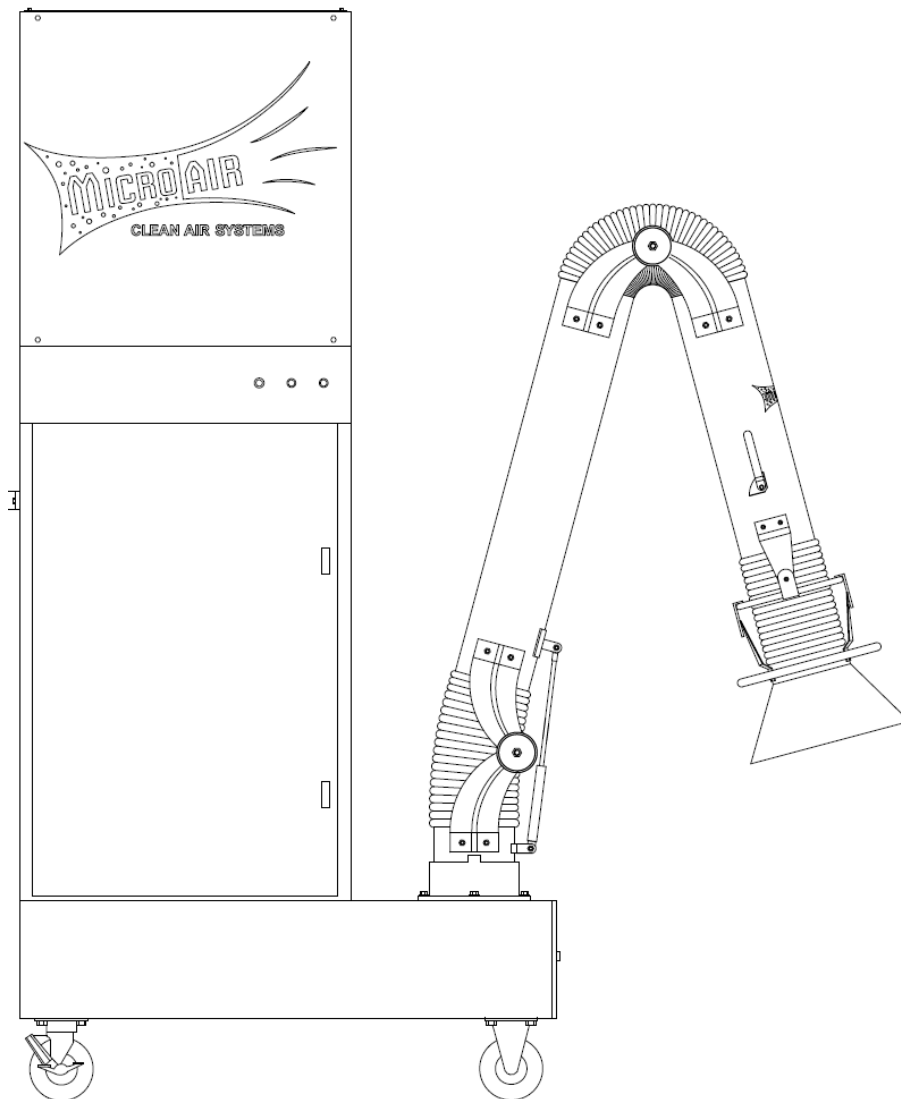

# MA4210

Installation and Operation Manual



This manual contains specific cautionary statements relative to worker safety. Read this manual thoroughly and follow as directed. It is impossible to list all of the hazards of dust control equipment. It is important that use of the equipment be discussed with a Micro-Air Representative. Persons involved with the equipment or systems should be instructed how to operate in a safe manner.

**WARNINGS:**

**CAUTION:** Installation can cause exposure to live components. Disconnect electrical power before proceeding with installation. Proper Lock Out / Tag Out procedures should be used.



All electrical work must be done by a qualified electrician according to local, state and national codes.



Improper installation or operation of this equipment can cause damage to equipment and / or injury to personnel. The installation / operation manual must be read and followed in its entirety.

**MA4210 SPECIFICATIONS:**

Motor:	1-1/2 HP, 1725 RPM, 1 Phase, TEFC 3 HP, 1760 RPM, 3 Phase, TEFC
Input Voltage:	1-Phase - 120V, 60 Hz 3-Phase - 230/460V, 60 Hz
Max Current:	1-Phase - 16 Amps 3-Phase - 8.4/4.2 Amps
Blower:	12-9 Belt Driven
Dimensions:	86"H x 26"W x 36"L
Shipping Weight:	444 lbs.
Actual Weight:	402 lbs.*

\*Add 35 lbs. per charcoal module when selected.

**PACKAGE CONTENTS:**

1 Ea.	MA4210	16 Ea.	5/16-18 Bolt
1 Ea.	Owner's Manual	16 Ea.	5/16-18 Hex Nut
2 Ea.	Swivel Caster	16 Ea.	5/16" Flat Washer
2 Ea.	Fixed Caster	16 Ea.	5/16" Lock Washer
1 Ea.	Filter Hanger Bar	1 Ea.	Handle

**EQUIPMENT / TOOLS REQUIRED:**

- Forklift or Hoist
- Lifting straps or chains
- Socket wrenches
- Wire nuts

**PRE-OPERATING INSTRUCTIONS:**

1. Inspect the unit for any visible damage that may have occurred during shipment. Report any damage to the delivery carrier.
2. Remove the shipping crate, shipping straps and plastic wrap from unit. Discard skid and hardware.
3. Open the filter door and remove the bag filter, pre-filter, hood, handle, and filter hanger bar.
4. Lay the unit down on its back (the side opposite the hose).
5. With the unit still in the horizontal position, secure the casters to the bottom of the unit using bolts, nuts and washers provided.
6. Slide the pre-filter into the channels provided at the bottom of the unit making sure that the air flow directional arrows are pointed upward.
7. Making sure that the loops on the filter are towards the door, carefully slide the bag filter back into the cabinet. Do not snag or rip the delicate media material that is used to make this filter. When properly inserted, the bag filter will not protrude past the filter slide and will allow the door to close securely.
8. Insert the filter hanger bar through the loops in the inside the cabinet near the top of the filter door.
9. Close and latch the filter door.
10. Determine the location where the unit is to be installed. Be sure to allow sufficient access to the unit for servicing and maintenance on all sides.

**ELECTRICAL CONNECTIONS:**

**All electrical work must be done by a qualified electrician according to local, state and national codes. Be sure that the designated circuit breaker is off until all wiring has been completed.**

NOTE: It is recommended that a properly sized motor starter and overload protector be used in the supply circuit of the 3 Phase motor. The 120V units have thermally protected motors with on/off switches.

1. Make electrical connections as shown in the wiring diagram to the wires protruding from the conduit on the side of the unit.
2. Check blower for proper rotation direction. Blower should rotate clockwise when viewed from the pulley end. If the blower rotates backwards, interchange two of the motor supply connections.
3. Check current draw of the motor. Do not exceed Amps specified.

**PRE-OPERATING CHECKLIST:**

- Check blower drive belt for proper tension. Belt should deflect  $\frac{3}{4}$ " when firm pressure is applied midway between the pulleys.
- Check that motor, blower and drive pulleys are mounted securely.
- Make sure that both corners of every pocket in the filter bag is supported by the filter support rods and that filter support rods are fully engaged in their support brackets.
- Air flow direction arrows on the pre-filters must point toward the blower.
- Make sure all access panels removed during the installation are re-installed and the filter access door is closed.

**OPERATING INSTRUCTIONS:**

1. Choose a suitable, level place near the workstation and position the unit so that the arm assembly will be placed near the source of pollution being generated.
2. Grasp the hood by the handle ring and position within 18" of the source of pollution.
3. Connect power (stated above in ELECTRICAL CONNECTIONS).
4. Adjust the hood to capture the maximum amount of contaminants. Periodically adjust the position of the hood to keep it in maximum capture range.

**PRESSURE SWITCH ADJUSTMENT:**

1. The pressure switch which turns the light on with a differential pressure increase, should be wired to poles L1 (red) and L2 (blue) at the time of installation with 230/460 volt source (See Wiring Diagram).
2. The pressure switch is preset at the factory to indicate (light on) dirty filters, but may need readjustment due to a desire for earlier or later filter changes, a different combination of filters, or because the set point shifted during shipping. The pressure switch is also orientation sensitive. To re-adjust the switch, remove the hole plug in the side of the unit for access to the adjustment screw. Make sure filters and pre-filters are installed in unit. Turn the unit on and place a piece of cardboard over the intake covering about 80% to 85% of the intake area. With a standard screwdriver, turn the adjustment screw clockwise until the light goes off, or counterclockwise until the light comes on.
3. For more time between filter changes (less air flow), cover slightly more of the opening, and for less time between filter changes (more air flow), cover less of the opening.

**GENERAL MAINTENANCE:**

- Occasionally check the condition of the drive belt for tightness and wear.
- Check the bower bearings for unusual wear and the blower wheel for debris and dirt. Clean when necessary.
- Check the wiring for loose connections or for cracked insulation.
- No lubrication is required for the motor because it is a permanent pre-lube design. Excessive dirt/oil should be periodically removed.
- Once per month grease the suction arm base assembly with a bearing grease listed to not react with aluminum.

**CHANGING FILTERS:**

**Always make sure that the unit is turned off before changing filters or servicing the unit.**

1. The MA4210 is equipped with a filter change light or optional Magnehelic Gauge. If the differential pressure has been set properly the light or gauge signals the need for examination for the filters.
2. When the light comes on, or gauge reads high differential pressure, turn the unit off and remove the pre-filter only. Replace with a new pre-filter, making sure that the air flow directional arrow is pointed toward the outlet end. Turn the unit back on. If the filter change light is off, or the gauge reads low differential pressure, then the unit is operating properly.

3. If the filter change light fails to go out, or the gauge continues to read high differential pressure after replacing the pre-filter, then the media filter also needs to be replaced.
4. To install a new bag filter, turn the unit off. Remove the filter from the channel and insert a new filter in place.
5. Start the unit. The filter change light should be off or gauge reads low differential pressure and the unit should be operating properly.

### AIR FLOW ADJUSTMENT:

Depending on the configuration, the MA4210 will be equipped with a variable diameter pulley on the motor to allow the air flow to be adjusted to the installation requirements. The pulley is set for maximum air flow from the factory. The air flow rate can be adjusted as follows:

1. Remove motor compartment access cover. Be careful to avoid tearing gasket material between door and cabinet.
2. Remove belt.
3. Loosen pulley adjustment set screw on motor pulley and screw adjustable sheave out away from fixed sheave. Tighten set screw onto flat of fixed screw (FIG. 1).
4. Adjusting the motor pulley may require a size larger or smaller belt, depending on the application.
5. Replace belt and check belt tension. Proper tension should be between 1/2" and 3/4" deflection when belt is squeezed with normal pressure between fingers.
6. Replace motor compartment access cover.
7. Recheck for correct draw of motor amperage. NOTE: All filters and panels must be installed on unit and door must be closed for current measurements of motor.

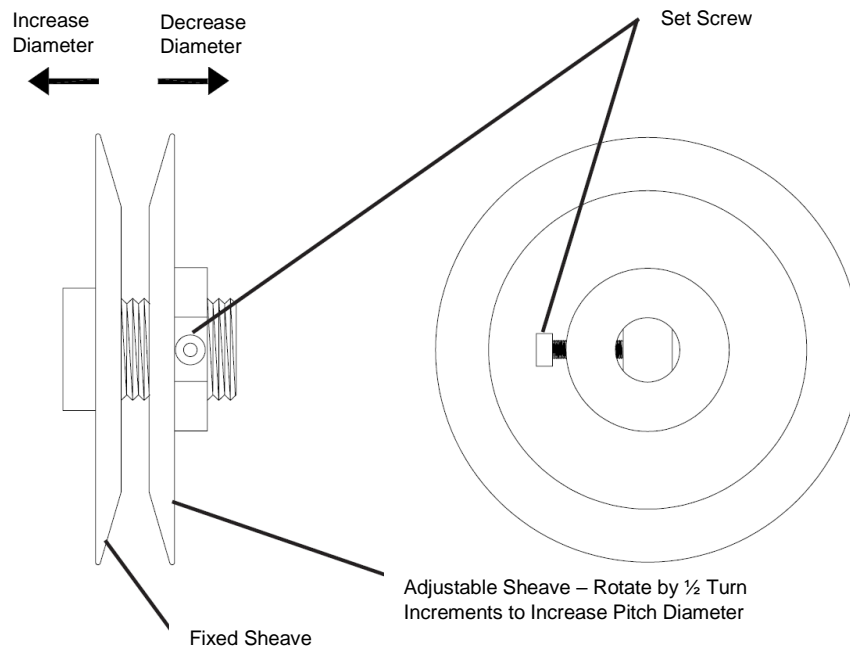

FIG. 1

**INSTRUCTIONS FOR SIDE DISCHARGE BLOWER EXHAUST:**

**Read instructions completely before making changes. Due to relocation of internal components, some wiring may be loose. Be sure to retain wires so they will not become loose in air stream of blower inlet.**

1. The MA4210 motor/blower module can be rotated so that the exhaust air exits from the side of the unit. Before rotating the motor/blower module be sure that all input power is disconnected and the unit is turned off.
2. Remove the motor access door and exhaust grille.
3. Remove 5/16" hex bolts and washers that secure the motor/blower module to the filter module.
4. Rotate the motor/blower module 90 deg. (FIG. 2).
5. Using 5/16" hex bolts and washers, re-secure the motor/blower module to the filter module.
6. Re-install motor access door and exhaust grille.
7. Reconnect input power and turn unit on. Check for proper air flow and blower rotation.

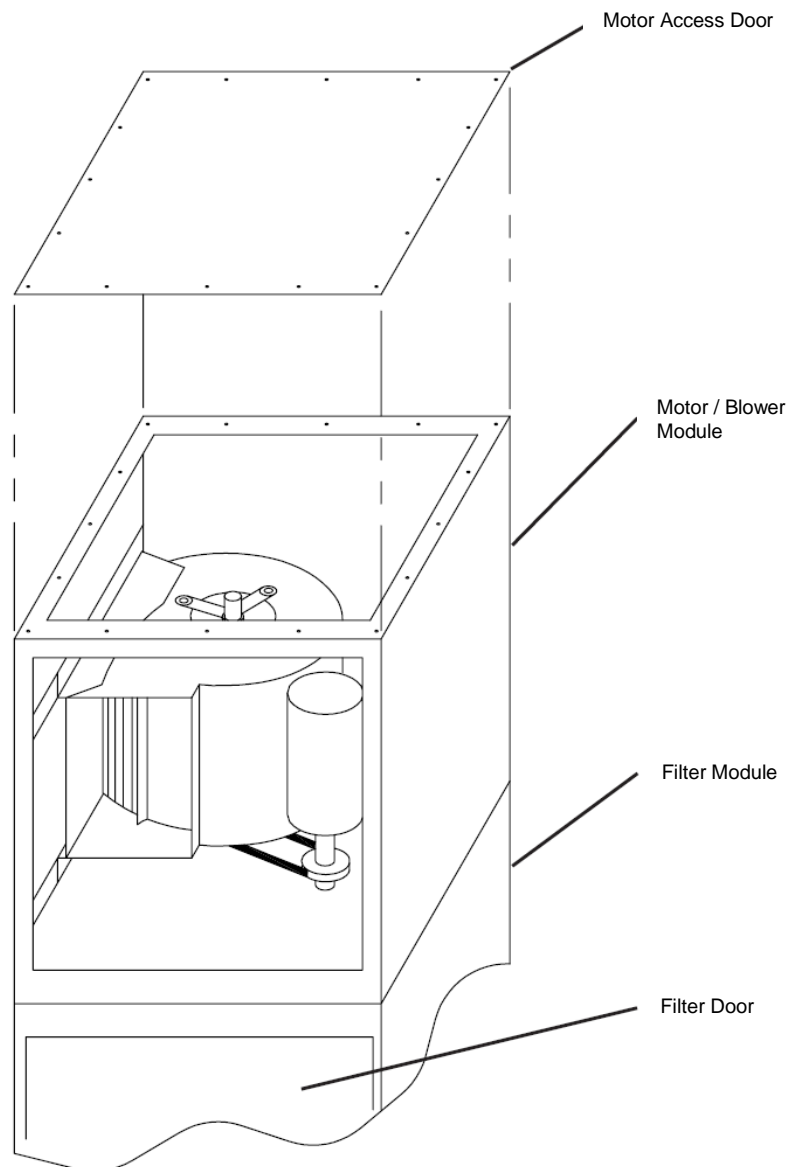

FIG. 2

**UNITS WITH HEPA OR CHARCOAL AS A SECOND MAIN FILTER:**

On units with optional HEPA or charcoal filters, an adjustable filter track kit is used to complete the seal of the filters to the filter stop (FIG. 3 & FIG. 4). If the unit was ordered with either a HEPA or charcoal filter, the adjustable filter track kit is included with the unit. If a HEPA or charcoal filter is ordered as an after-market item, the adjustable filter track kit should be ordered as well. Order part number 38036-01.

Each filter track kit is supplied with:

- 1 Ea. Filter Track
- 2 Ea. Supports
- 1 Ea. Handle
- 4 Ea. Retaining Brackets
- 1 Ea. Door Stop Bracket
- 3 Ea. Horizontal Support
- 16 Ea. #8-32 Self Tapping Hex Screws

**INSTALLATION:**

1. Place supports in cabinet at a dimension of 13-1/4" and secure with self-tapping screws.
2. Place track in cabinet so it rests upon supports and 1/2" diameter pin is located behind brackets on supports.
3. Place handle on supports so that it rests in notches.
4. Lock 1/2" diameter rods on handle and track in place with brackets and self-tapping screws.
5. Place handle stop bracket at a dimension of 15-1/2" and secure with self-tapping screws. This is to keep handle from rotating past 90 degrees and allowing filter to loosen.
6. Horizontal support is not used in this application.

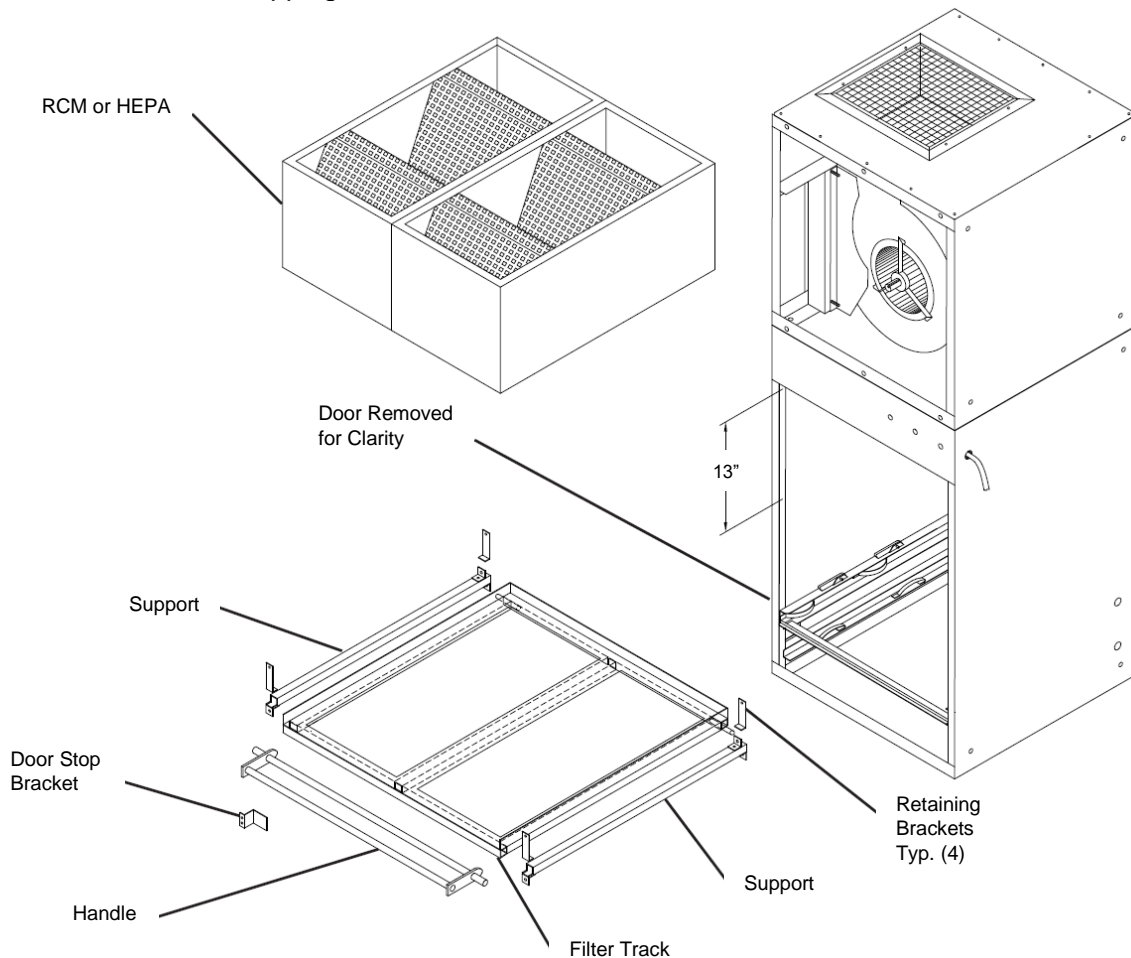

FIG. 3

**UNITS WITH HEPA OR CHARCOAL AS A FIRST AND SECOND MAIN FILTER:**

On units with optional HEPA or charcoal filters, an adjustable filter track kit is used to complete the seal of the filters to the filter stop (FIG. 3 & FIG. 4). If the unit was ordered with either a HEPA or charcoal filter, the adjustable filter track kit is included with the unit. If a HEPA or charcoal filter is ordered as an after-market item, the adjustable filter track kit should be ordered as well. Order part number 38036-01.

Each filter track kit is supplied with:

- 1 Ea. Filter Track
- 2 Ea. Supports
- 1 Ea. Handle
- 4 Ea. Retaining Brackets
- 1 Ea. Door Stop Bracket
- 3 Ea. Horizontal Support
- 16 Ea. #8-32 Self Tapping Hex Screws

**INSTALLATION:**

1. Place supports in cabinet at a dimension of 24-5/8" and secure with self-tapping screws.
2. Place track in cabinet so it rests upon supports and 1/2" diameter pin is located behind brackets on supports.
3. Place handle on supports so that it rests in notches.
4. Lock 1/2" diameter rods on handle and track in place with brackets and self-tapping screws.
5. Place handle stop bracket at a dimension of 27" and secure with self-tapping screws. This is to keep handle from rotating past 90 degrees and allowing filter to loosen.
6. Place horizontal supports (Typ. for two) on sides of cabinet at a dimension of 10" and the other horizontal support on rear cabinet at 5" and secure with self-tapping screws.

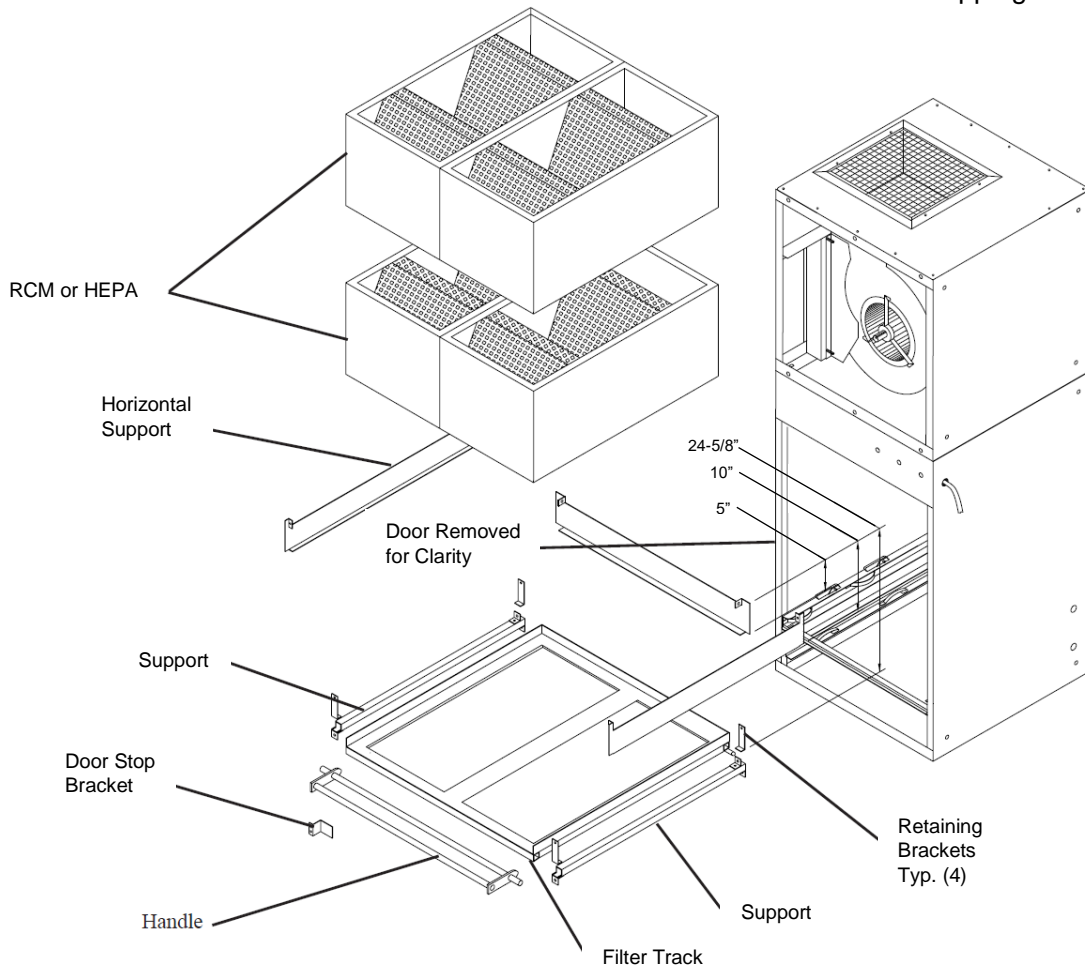

FIG. 4



**FILLING OF RCM MODULES:**

1. Remove bulk charcoal or purasorb from the shipping container.
2. Set module on a level surface. Remove fill cover by removing six #10-32 Phillip head screws that secure cover. Set cover aside (FIG. 5).
3. Open the lid of the charcoal or purasorb bucket. Pour the material from the plastic bag into the module through the slots. It may be necessary to slightly shake the module to assure an even fill. Excess material may be saved by resealing the bucket. Note that slow pouring will minimize dust that will be present during filling.
4. After filling the module, discard the bucket and reinstall the fill cover removed in step 2.
5. With filter track in place and handle pulled out away from cabinet load RCM modules into track.
6. With filters in place rotate handle 90 deg. and lock filter modules in place.

NOTE: The MA4210 requires two modules when used as a second main filter and four modules when used as a first and second main filter.

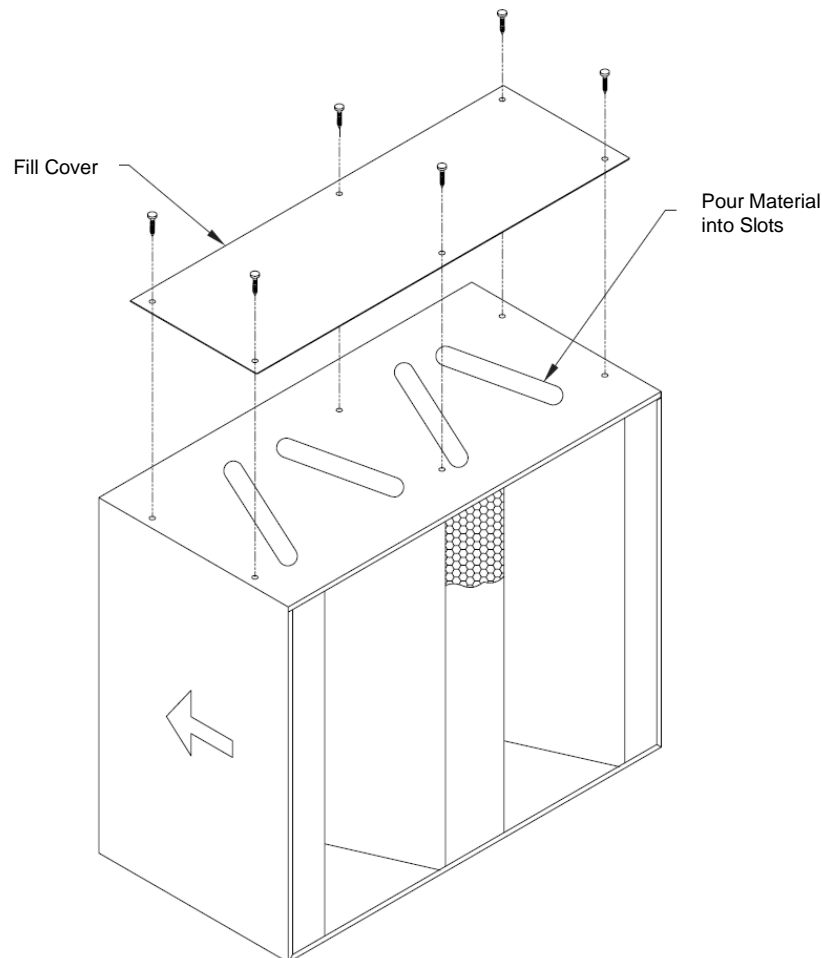

FIG. 5

**OPTIONAL SILENCER INSTALLATION:**

1. Remove exhaust grille from unit as shown in Fig. 6.
2. Slide silencer over blower assembly.
3. Align holes from silencer with those located on side of the blower assembly.
4. Attach silencer to blower assembly using 3/8" bolt, lock washer and flat washer.
5. Center exhaust grille over hole in silencer and attach using #8-32 self-tapping machine screws.

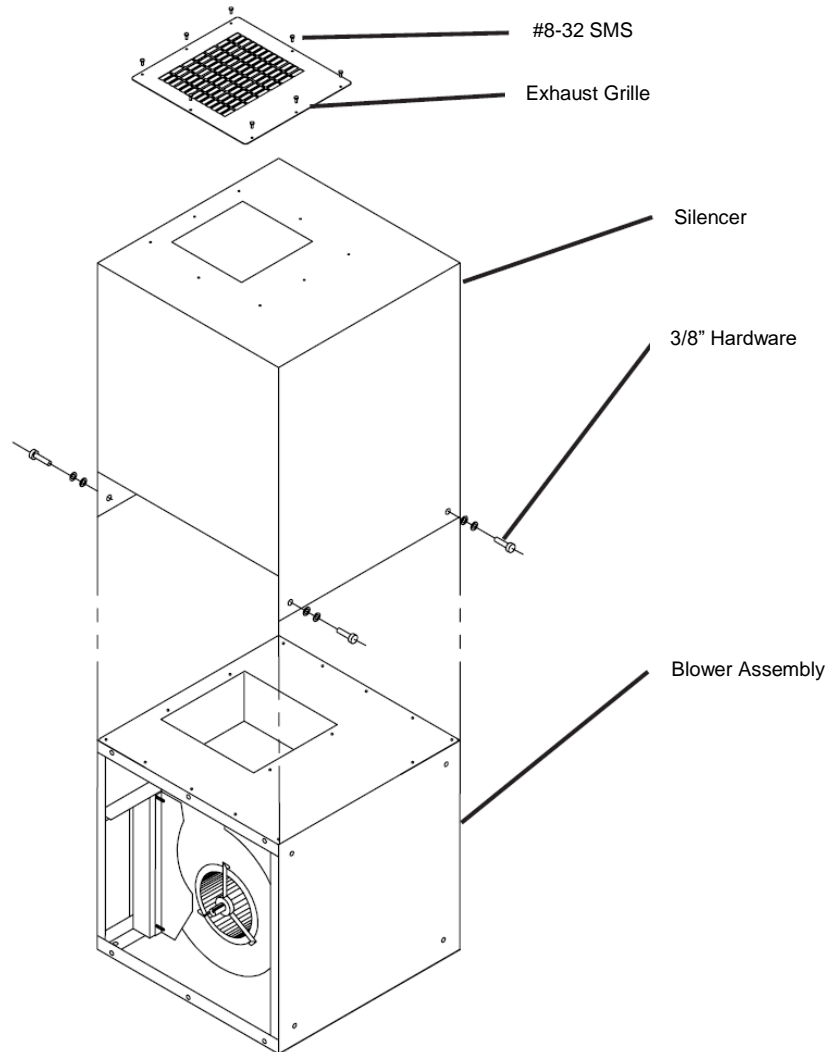

FIG. 6

**WIRING DIAGRAM:**



**All electrical work must be done by a qualified electrician according to local, state and national codes.**

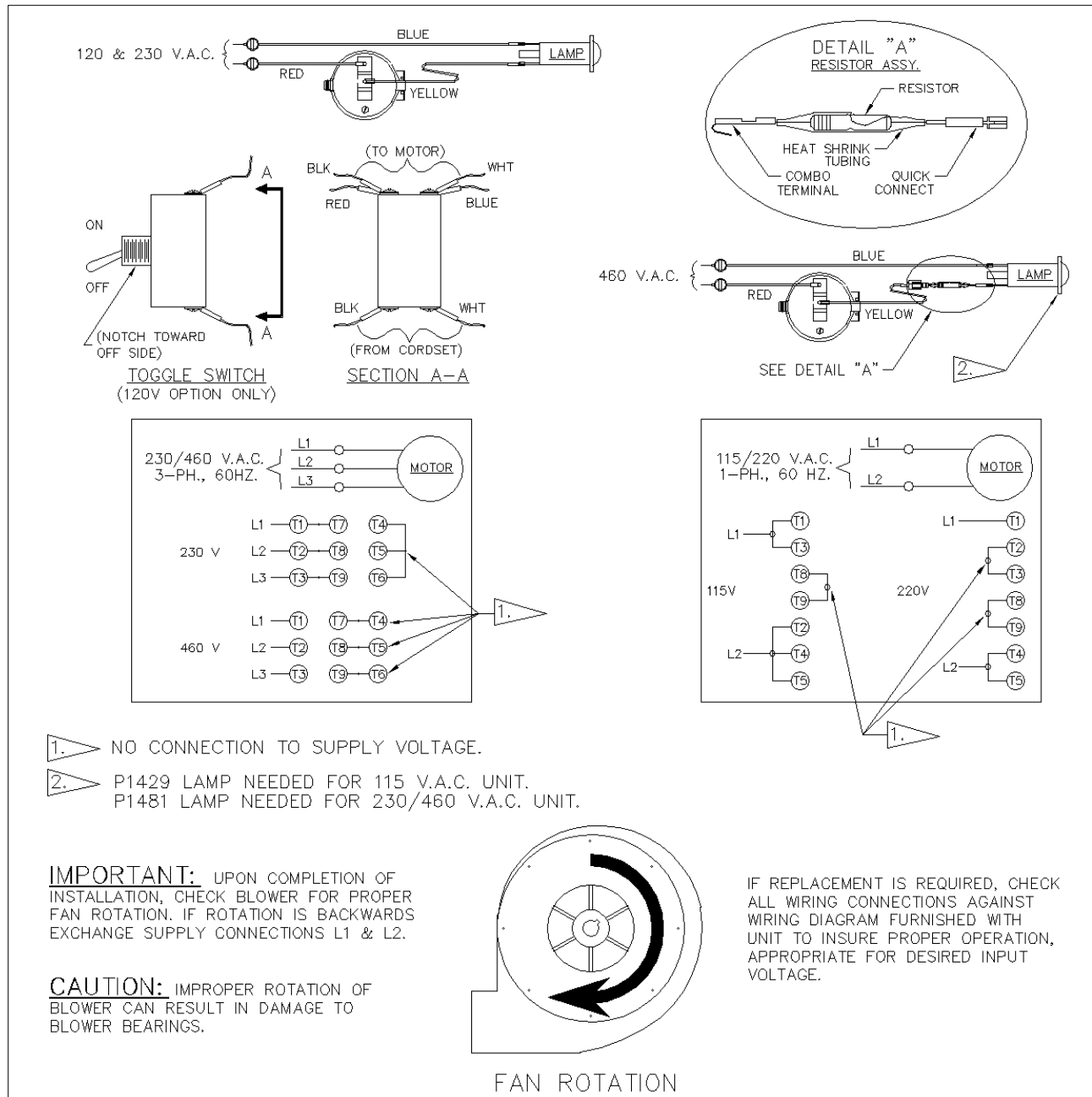

FIG. 7

**TROUBLESHOOTING:**



**CAUTION:** Before disassembling the unit or doing any inspecting of the parts, make certain that the power has been cut off and the blower has come to a complete stop. NEVER run the unit with the access door opened or the panels removed.

TABLE 1 – Troubleshooting Chart

PROBLEM	POSSIBLE CAUSE	REMEDY
Unit fails to start	No incoming power	Check the circuit and switch
	Blown breaker or fuse	Replace fuse or throw breaker
	Loose wire in terminal box	Reconnect wire
	Burned out motor	Replace motor
	Primary voltage to motor contactor is below 10% tolerance	Take steps to increase voltage to primary
	Motor thermal trip (1 Phase only)	Reset at motor
Unit runs slowly, Inadequate capture	Tripped overload (3 Phase only)	Reset overload protector
	Wired for wrong voltage	Check input voltage Check wiring diagram
	Improper rotation	Check wiring diagram Switch L1 & L2 (3 Phase only)
	Internal Obstruction	Check if damper is open Check inlet for blockage Check hoses for proper connection Check hoses for holes
	Pulleys set for improper static	Adjust or change pulleys
Dirty filters	Service/Replace filters	
Vibration	Loose motor mounting bolts	Tighten bolts
	Foreign objects in blower/ Build-up on blower wheel	Remove debris from blower
	Dirty filters	Service/Replace filters
Mist coming from exhaust	Dirty disposable filters on torn filters	Service/Replace filters
	Air bypass around filters	Check for proper seal against picture frame and seals on door and back wall
Stronger resistance during rotation of the arm	Lack of grease in the rotating socket	Lubricate the rotating socket
Arm will not stay in place	Joints are loose	Tighten the joints

ARM ASSEMBLY PARTS LIST:

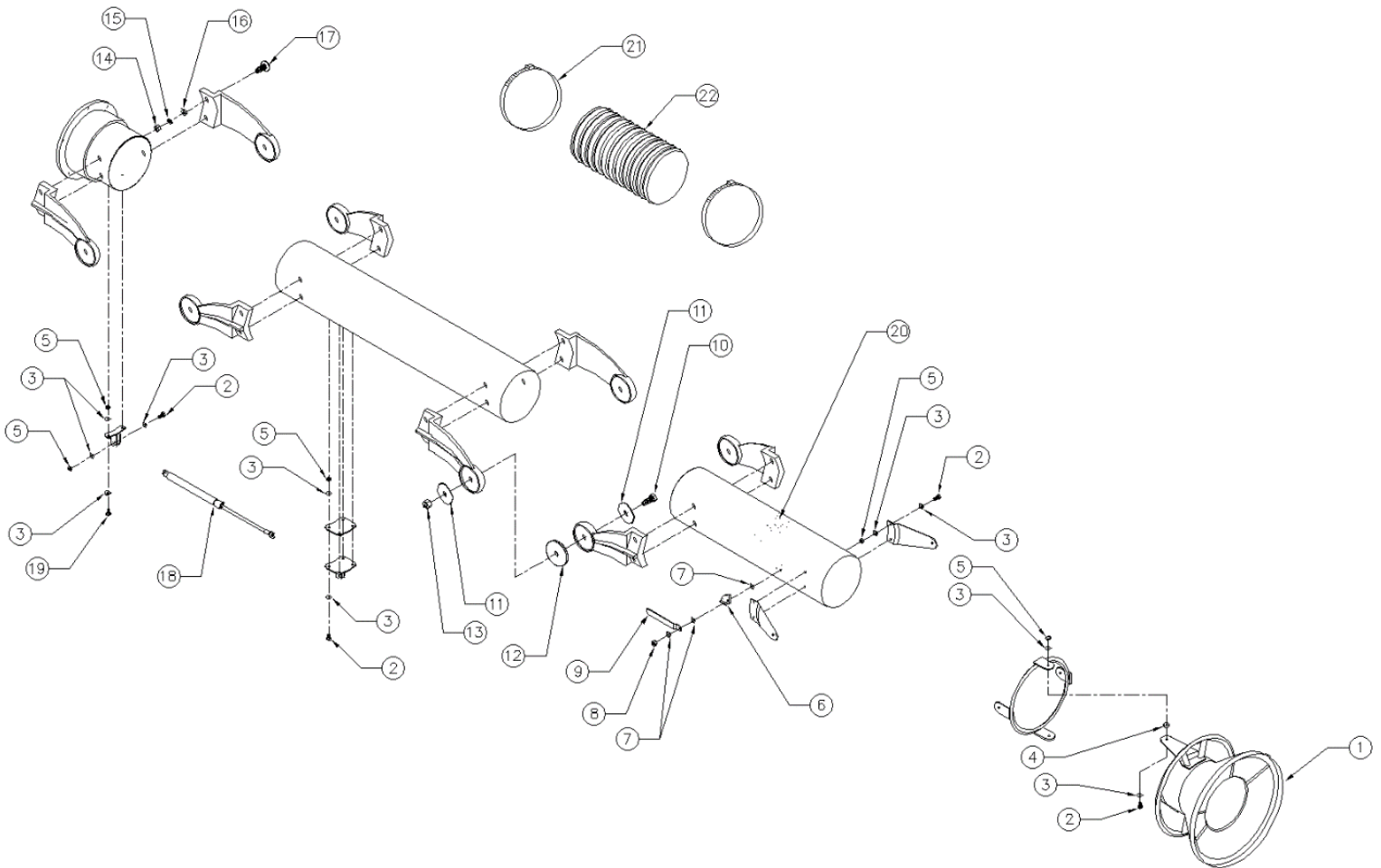

FIG. 8

ITEM	PART NO.	DESCRIPTION	ITEM	PART NO.	DESCRIPTION
1	P2466	6" Hood Assembly	13	P2479	1/2-13 Nyloc Hex Nut
	P2469	8" Hood Assembly	14	P141	3/8-16 Hex Nut
2	P164	1/4-20 x 3/4" Hex Head Bolt	15	P142	3/8" Lock Washer
3	P246	1/4" Flat Washer	16	P2206	Flat Washer
4	P2482	Hood Disc Pad	17	P2481	3/8-16 x 1-1/4" Carriage Bolt
5	P2485	1/4-20 Nyloc Hex Nut	18	P2461	6" Gas Shock
6	37104-01	Damper Handle Stop Plate		P2462	8" Gas Shock
7	P2206	5/16" Flat Washer	19	P2483	1/4-20 x 1" Hex Head Bolt
8	P2484	5/16-18 Nyloc Hex Nut	20	P2312	Micro Air Decal
9	37103-01	Damper Handle	21	P2232	Hose Clamp
10	P2478	1/2-13 X 2.25" Hex Head Bolt	22	P2491	6" Dia. Flex Hose
11	P2468	Cup Washer		P2617	8" Dia. Flex Hose
12	P2467	Friction Pad			

MA4210 ASSEMBLY PARTS LIST:

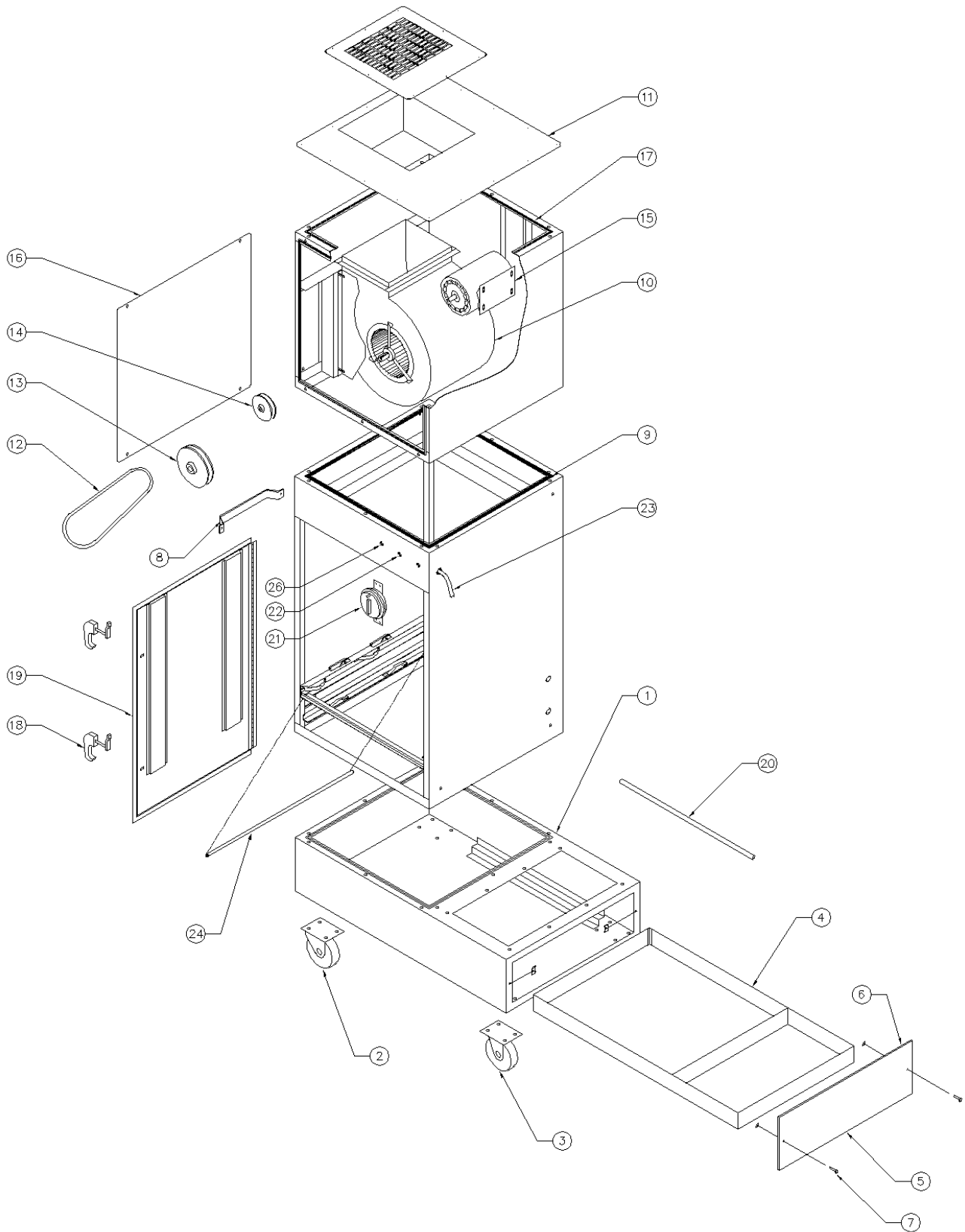

FIG. 9

**MA4210 ASSEMBLY PARTS LIST:**

<b>ITEM</b>	<b>PART NO.</b>	<b>DESCRIPTION</b>	<b>ITEM</b>	<b>PART NO.</b>	<b>DESCRIPTION</b>
1	38027-01	Base Assembly	14	P2105	1-1/2HP Var. Pitch Dia. Motor Pulley
2	P3283	Swivel Caster		P3578	3HP, Var. Pitch Dia. Motor Pulley
	P2724	Big Wheel		P3986	3HP, 7.75" Motor Pulley
3	P3284	Rigid Caster	15	P3545	1-1/2HP, 120V, 1 Phase Motor
4	38033-01	Spark Tray		P3495	3HP, 230/460V, 3 Phase Motor
5	33299-03	Spark Tray Door	N/S	30251-01	Mounting Bracket for P3495 Motor
6	P1809	Foam Gasket	16	38011-02	Motor Access Door
7	P1856	Spark Tray Door Latches	17	P1032	Access Door Gasket
	P1857		18	P1372	Latch
	P1858		19	38022-01	Filter Access Door
8	30473-01	Handle	20	33346-02	Filter Rod
9	38070-01	Cabinet Assembly	21	P3505	Pressure Switch
10	P3498	Blower	22	P3206	On/Off Switch (120V Only)
11	38010-01	Blower Access Panel	23	P1363	Cord Set (120V Only)
12	P1495	42" Belt	24	P3214	Seal Gasket
	P3207	43" Belt	26	P1429	Light (120V)
	P3550	49" Belt		P1481	Light (230V, 460V)
	P7135	51" Belt	N/S	P3547	Wiring Diagram
13	P1710	4.95" Blower Pulley	N/S	P2250	Magnehelic Gauge
	P1504	5.45" Blower Pulley	N/S	38050-01	Silencer
	P1974	6.25" Blower Pulley	N/S	38036-01	Filter Track
	P3218	8.00" Blower Pulley			
	P3270	9.75" Blower Pulley			

**REPLACEMENT FILTER LIST:**

<b>PART NO.</b>	<b>DESCRIPTION</b>	<b>PART NO.</b>	<b>DESCRIPTION</b>
P1411	24" x 24" x 4" Pleated Pre-Filter	P1799*	24" x 24" x 2" Baffle Oil Impinger
P1439	24" x 24" x 32" 55% Bag Filter	P2101	24" x 24" x 12" 99.97% DOP HEPA
P1442	24" x 24" x 32" 95% Bag Filter	P2179	24" x 24" x 32" 95% Oil Mist Bag Filter
P1455	24" x 24" x 12" 95% DOP HEPA	33740-00	Refillable Module
P1460	24" x 24" x 15" 95% Short Bag Filter		P1450 - Purasorb Media
P1461*	24" x 24" x 2" Pleated Pre-Filter		P1823 - Charcoal Media
P1475*	24" x 24" x 2" Mesh Oil Impinger		

\*NOTE: 2" Pre-Filters must be used in combination to fill 4" channel.

