

MICRO AIR[®]

AIR CLEANERS



Model OM 6000

OWNER'S MANUAL

CAUTION

Read complete instructions before operating.
Please file for future reference.

MODEL OM 6000 SPECIFICATION

Input Volts:	208-230/460 VAC, 60Hz, 3 Phase
Max. Current:	208-230 VAC - 19.8 Amps 460 VAC - 9.9 Amps
Motor:	7 ½ HP Motor, TEFC, 3 Phase @ 1740 RPM
Dimensions:	106" h x 36" w x 42" d.
Weight:	750 lbs.

PACKAGE CONTENTS **

- 1 ea. Blower and Filter Module Assembly
- 1 ea. Inlet Plenum
- 1 ea. Floor Stand (Optional)
- 1 ea. Owner's Manual

**Contents may vary due to CTO configuration ordered.

UNPACKING INSTRUCTIONS

1. Cut the shipping straps, remove the carton and plastic wrapping from the unit.
2. Remove the OM6000 from the shipping skid.
3. Inspect the unit for any possible damage that may have occurred during shipping. File any damage claims with the delivery freight carrier upon receipt of the unit.

LOCATION CRITERIA

- Three feet of unobstructed exhaust space from the outlet of the unit.
- Allow sufficient room to access the front and back of the unit for servicing and maintenance.
- Place as near as possible to the source of oil mist or other pollutant that is to be captured.
- Contact your local Micro Air distributor to determine proper pulley combination handle the static pressure of your particular system.

MOUNTING OPTIONS

A. CEILING MOUNT

CAUTION: When installation requires that the unit be suspended from the ceiling structure, the structure must be sufficient to support at least 4 times the maximum weight of the unit.

1. Determine a site that meets all of the location criteria.
2. Using the hanging brackets on top of the unit, suspend the unit from the ceiling by use of solid rod or angle brackets.

CAUTION: Use solid rod or steel brackets capable of supporting 750 pounds to support the air cleaner.

B. FLOOR MOUNT

1. Locate an installation site on a level surface that meets the location criteria.
2. Bolt the floor stand securely to the floor (see Figure 1).

CAUTION: Failure to bolt the floor stand to the floor may cause serious bodily injury.

3. Bolt the plenum to the floor stand. (Note: This may have already been done at the factory.) Drill four 1/2" holes through the legs of the floor stand and plenum. Place unit onto the plenum. Attach using 3/8" hardware.

CAUTION: The size and weight of the OM6000 requires a mechanical means to lift and hold the unit during installation.

Secure the unit to the plenum, using the provided 3/8" hardware. Seal with RTV sealant. (See FIG. 1.)

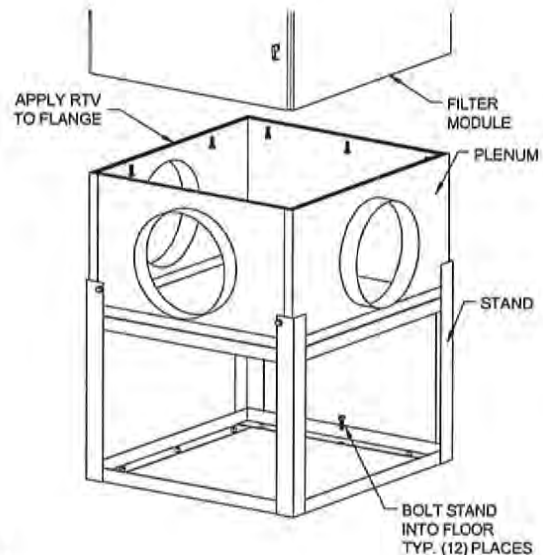

FIG. 1

6. If desired the unit may also be secured from the ceiling, refer to ceiling mount instructions for proper installation.

OIL DRAINAGE

NOTE: Make sure to follow local codes when disposing of captured oil.

Provisions for draining oil from this unit is provided for by a 1" N.P.T. pipe coupling on the bottom of the unit. Drainage can be piped to a central collection system or collected in a bucket placed under the unit. In all cases a shut-off valve or drain trap is required to prevent air bypass through the drain opening. One of the drain systems shown in FIG. 2 should be used. Drain connections and lines are not provided.

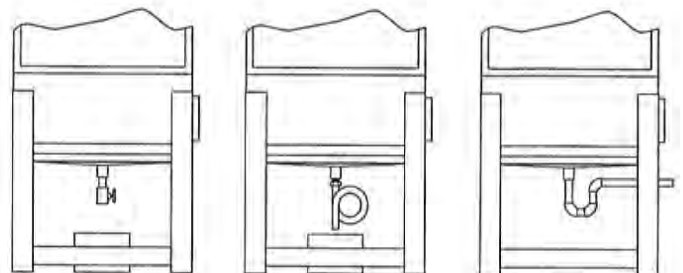

FIG. 2

NOTE: If a shut-off is installed in the drain system, the unit must be emptied regularly to prevent oil from overflowing into the intake duct.

ELECTRICAL CONNECTIONS

CAUTION: Installation can cause exposure to live electrical components. Disconnect electrical power before proceeding with installation.

1. Conduit electrical connections should be made by a qualified electrician, and must comply with local electrical codes.

NOTE: It is recommended that a 7-1/2 HP magnetic motor starter/protector be used in the supply circuit to this unit.

2. Make electrical connections from power supply to L1, L2, and L3. Wire size should be suitable for 7-1/2 HP load. See Wiring Diagram on Page 5.
3. Check blower for proper rotation. See FIG. 3.

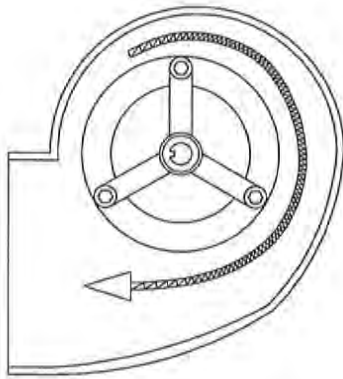

FIG. 3

4. For all air cleaners purchased with pulleys, it is strongly recommended to measure motor current during initial start up. This procedure will insure that the motor is not being overloaded due to inappropriate blower RPM or overestimated static pressure of the total system.

IMPORTANT: Measure motor current upon installation of OM6000. Excessive current will cause overload protection to engage resulting in shutdown of system motor.

5. If motor current is higher than rated (208/230 VAC - 19.8 amps and 460VAC - 9.9 amps), blower RPM may need to be reduced. DO NOT continue operation. Contact your Micro Air representative for correct pulley size.

OPERATION

MAGNEHELIC GAUGE OPERATION

1. As the filters collect airborne pollutants, they will eventually begin to become "loaded", which will cause an increase in static pressure and a decrease in airflow.
2. The magnehelic gauge on the control panel indicates static pressure. Note the reading at the initial start-up. As the unit is operated, the static pressure will gradually increase as the filters become loaded. This will indicate the need to clean or change the filters.

CHANGING FILTERS

1. Turn unit off.

2. Open filter access door. (If additional access is required the back filter access panel may be removed. Although, this is not necessary.)
3. Remove only the prefilter from the unit.

A. Baffle Impinger and Mesh Prefilters

Wash these prefilters in a detergent solution to remove dirt and oil residue. Rinse them thoroughly with water, shake dry and replace them in the unit with the airflow direction pointing to the blower.

B. Pleated Prefilters

Replace with a new filter with the airflow direction pointing to the blower.

4. Close the access door and reinstall back panel, if removed.
5. Turn unit on, if magnehelic gauge is still indicating high static pressure, then the bag filter needs to be replaced.
6. Visually inspect the bag filter. If the pockets are loaded with oil and dirt, then remove the filters by disconnecting the filter rod from the unit and disengaging the positive sealing system. (See FIG. 4.)

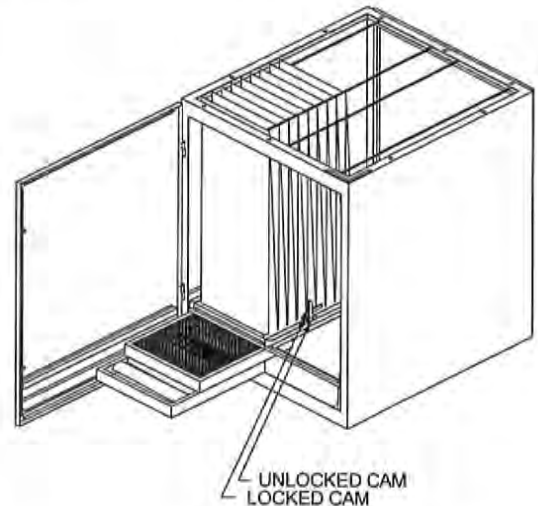

FIG. 4

7. To install new bag filters slide two filters in back to back on one side of the unit. Run two filter rods through the loops on both bags. Install the rods in the appropriate locations at the front and back of the unit. Lock the positive sealing cams into position. Repeat this process with the other two filters.
8. Close the door and turn on the unit.

GENERAL MAINTENANCE

1. Occasionally check the condition of the drive belt for tightness and wear.
2. Periodically check the blower wheel for debris and dirt. Clean when necessary.
3. Periodically, inspect hardware for loose nuts and bolts on access doors and internal components. Tighten, if needed.
4. Periodically, inspect all wiring for loose connections and cracked insulation. Replace as needed.
5. Periodically, check that the oil is draining easily through the drain pipe.

TROUBLESHOOTING CHART

CAUTION:

BEFORE DISASSEMBLING THE UNIT OR DOING ANY INSPECTING OF THE PARTS, MAKE CERTAIN THAT THE POWER HAS BEEN CUT OFF AND THE BLOWER HAS COME TO A COMPLETE STOP. NEVER RUN THE UNIT WITH THE ACCESS DOORS OPEN OR REMOVED.

PROBLEM	POSSIBLE CAUSE	REMEDY
Unit Fails to Start	Dead Power Line Blown Fuse or Breaker Overload Protection Engaged Burnt Out Motor	Check Circuit and Switch Check Fuse or Breaker Reset Overload Protect Replace Motor
Unit Runs Slowly or Inadequate Capture Velocity	Wired for Wrong Voltage or Improper Rotation Dirty Filters	Check Input Voltage Switch L1 & L2 to Reverse Rotation Check Wiring Diagram Clean or Replace Filters
Vibration	Loose Motor Mount Bolts Foreign Object in Blower Dirty Disposable Filters	Tighten Bolts Remove Debris from Blower Service Filters

OM 6000 WIRING DIAGRAM

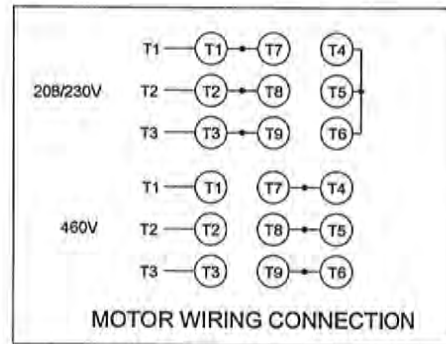
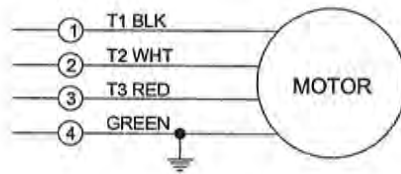

STANDARD WIRING

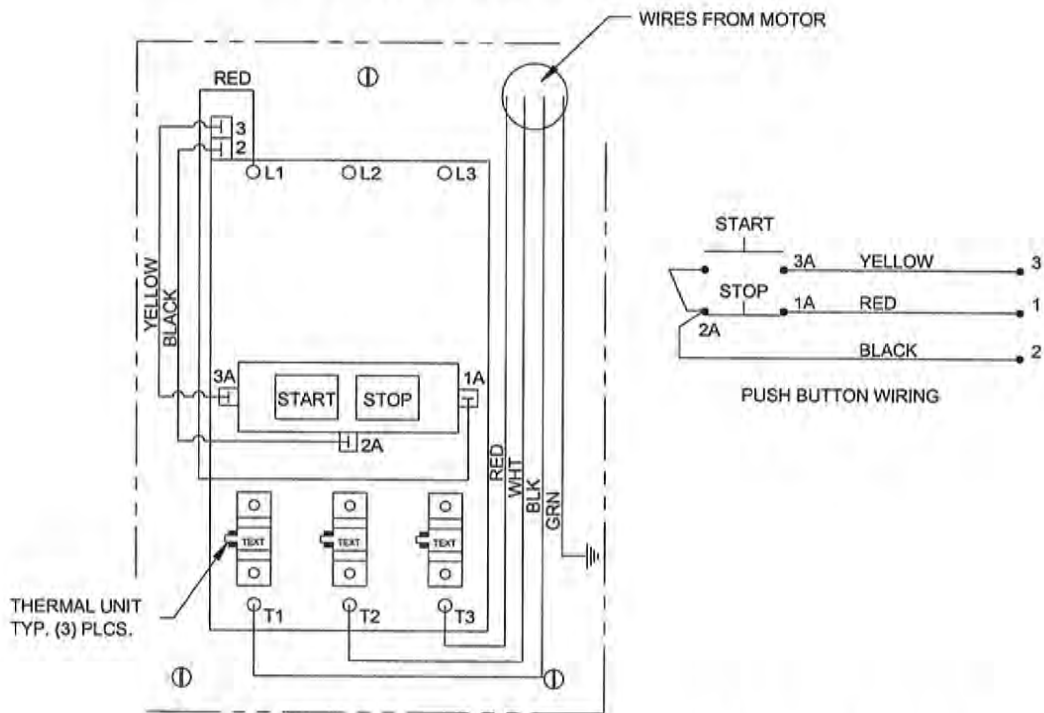

OPTIONAL CTO MOTOR STARTER WIRING

**OM 6000 PARTS LIST
BLOWER MODULE
(36760-01)**

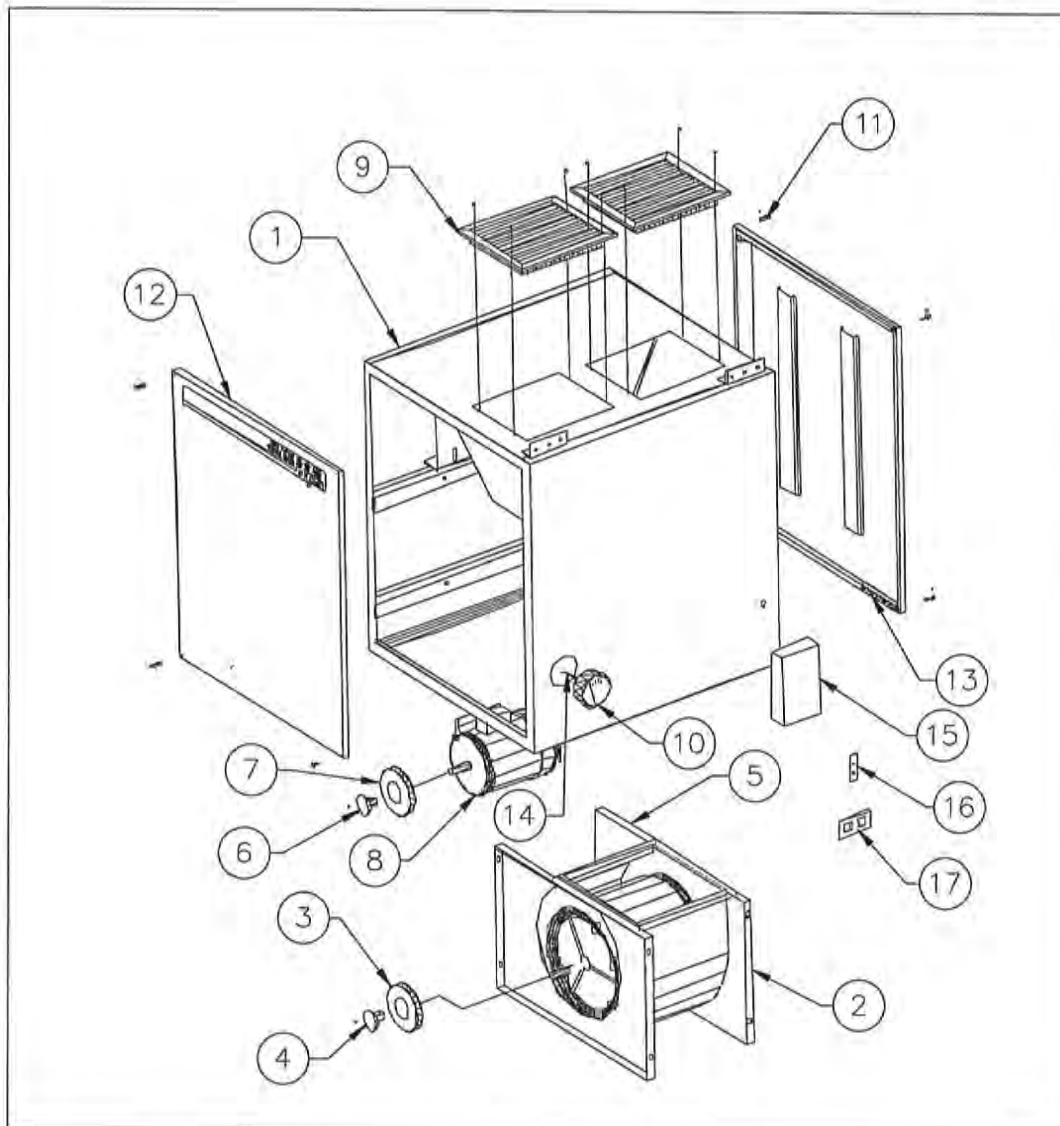

Item	Part no.	Description	Item	Part no.	Description
1.	36761-01	Cabinet Weldment	9.	P1977	Exhaust Grille
2.	36845-02	15-11 Blower assembly	10.	P2250	Magnehelic Gauge
3.	P3272	1-1/8" Bushing	11.	P3236	#12x2" Screw
4.	P3450	7.25" Pulley (1900 RPM)	12.	36774-01	Access Panel
	P3269	8.25" Pulley (1800 RPM)	*13.	P1367	1" Foam Gasket
	P3268	6.75" Pulley (1675 RPM)	14.	P2806	3/16" Tubing
*5.	P1367	3/4" Foam Gasket	15.	P1366	230V. Motor Starter (Optional)
6.	P3456	1-3/8" Bushing		P1367	460V. Motor Starter (Optional)
7.	P3269	8.25" Pulley (1950 RPM)	16.	P3469(3req'd)	230v. Thermal Unit (Optional)
	P3451	8.75" Pulley (1800 RPM)		P3468(3req'd)	460v. Thermal Unit (Optional)
	P3267	6.45" Pulley (1675 RPM)	17.	P3470	Stop/Start Switch (Optional)
8.	P3395	7-1/2 HP Motor			* Specify Length

**OM 6000 PARTS LIST
FILTER MODULE
(36757-01)**

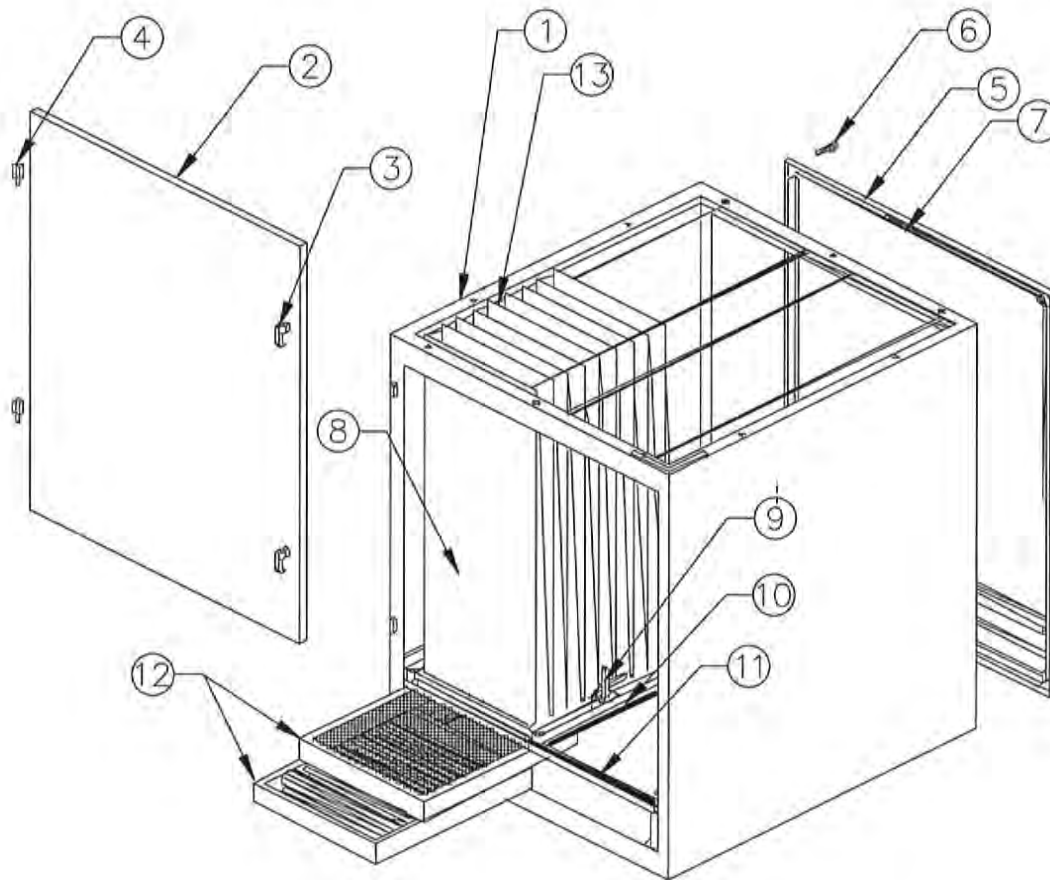

Item	Part No.	Description	Item	Part No.	Description
1.	36758-01	Cabinet Weldment	9.	33881-01	Cam
2.	36772-01	Filter Access Door Weldment	*10.	P3214	U-Channel Gasket
3.	P1372	Door Latch	*11.	P3215	Gasket w/ Lip
4.	P2835	Door Hinge	12.	P3459	2" Alum. Mesh Prefilter
5.	36773-01	Back Access Panel Weldment		P3460	2" Baffle Impinger
6.	P3236	#12 x 2" Screw		P3462	4" Pleated Prefilter
*7.	P1887	Trimseal Gasket		P3007	4" Mist-x (Cheveron Style)
8.	P3463	95% Bag Filter		P3000	Maxi-Grid Panel filter
	P3464	55% Bag Filter	13.	36776-01	Filter Rod
	P3465	95% Oil Mist Bag			

* Specify Length

**OM 6000 PARTS LIST
PLENUM AND STAND**

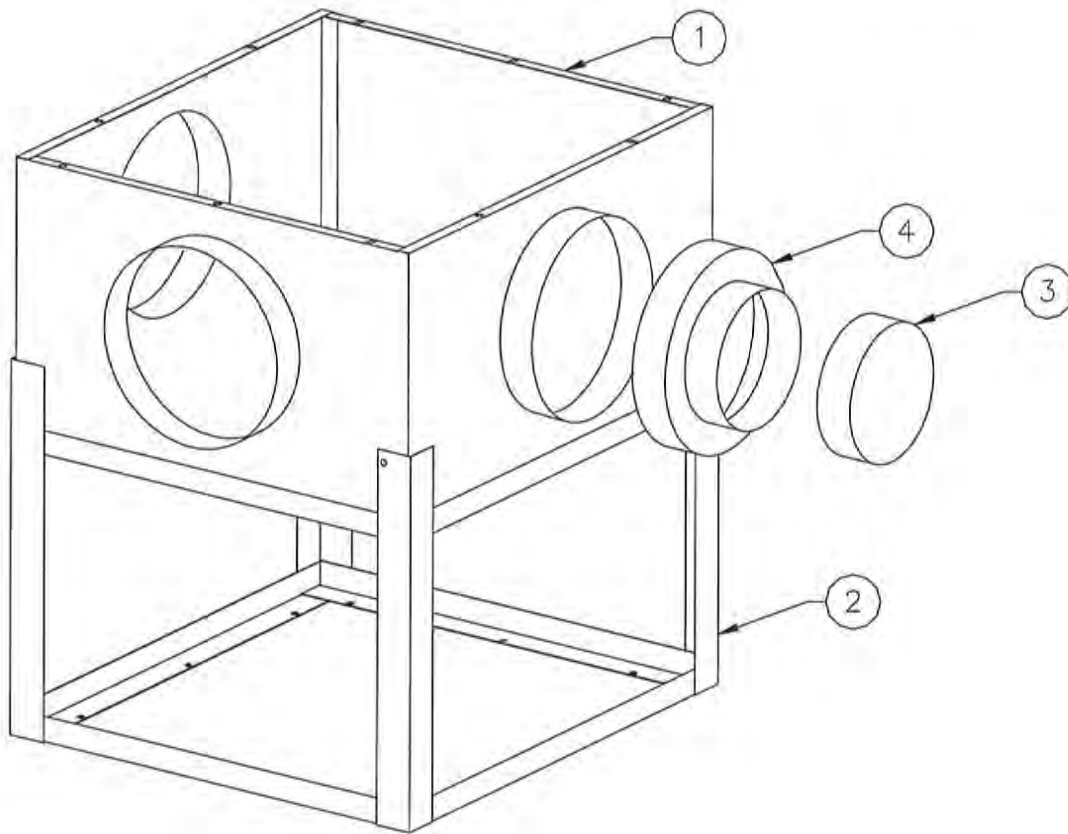

Item	Part No.	Description
1.	36750-03	Plenum Weldment w/ 3/16" Openings
2.	36754-01	Floor Stand (Optional)
3.	36781-01	16" Cover
	36781-02	14" Cover
	36781-03	12" Cover
	36781-04	10" Cover
4.	36784-01	16/14 Reducer
	36784-02	16/12 Reducer
	36784-03	16/10 Reducer

MICROAIR®
AIR CLEANERS

Products of Metal-Fab, Inc.
P.O. Box 1138 • Wichita, Ks 67201
(316) 943-2351 • FAX (316) 943-2717

©2001 Metal-Fab, Inc. Form No. L1447 08/01
6639