

MILCO AIR

®

AIR CLEANERS



Boom Arm

OWNER'S MANUAL

CAUTION

**Read complete instructions before operating.
Please file for future reference.**

BOOM ARM SPECIFICATIONS

Length: 10ft. / 14 ft.
 Weight: 130 lbs. / 150 lbs.
 Diameter: 6 in. or 8 in.

UNCRATING

Remove the Boom Arm assembly from the packaging skid that protects the assembly during shipping. Inspect the assembly for any damage that may have occurred during shipping. Any damage should be immediately reported to the nearest Micro Air® representative.

INSTALLATION INSTRUCTIONS

CAUTION: Due to the size and weight of the assembly, it is recommended that a minimum of two men and a forklift (or equivalent means) be used for installation.

1. Determine location where Boom Arm will be installed. The structure must be capable of supporting the Boom Arm with either the SCA600 or SCA800 series arm attached.
2. Using a forklift (or similar means) to position the Boom Arm up to the wall or vertical structure intended for installation, locate and drill 7/16" dia. mounting holes through the structure (Figure 1).

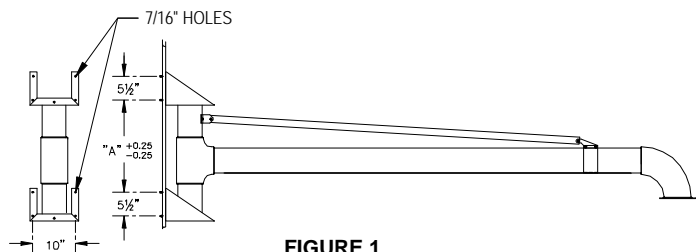

FIGURE 1

"A"	Description
22.875"	SCA600 Series
38.375"	SCA800 Series

3. Attach the Boom Arm to the wall structure using the 3/8" hardware provided (Figure 2).

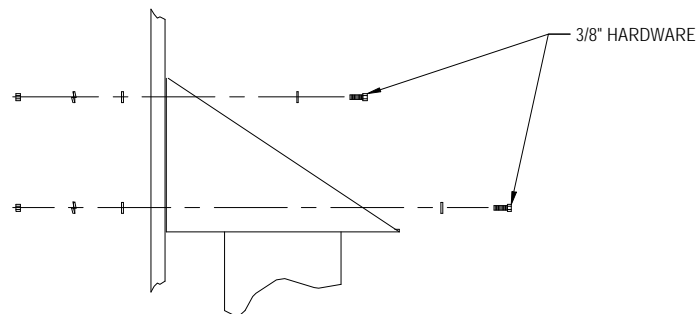

FIGURE 2

4. At this point, the Boom Arm should be tested to verify ease of movement. By applying force to the elbow at the end of the Boom Arm, test the movements from left to right.

5. After the Boom Arm is satisfactorily mounted, attach the SCA 600/800 series arm to the Boom Arm as shown (Figure 3).

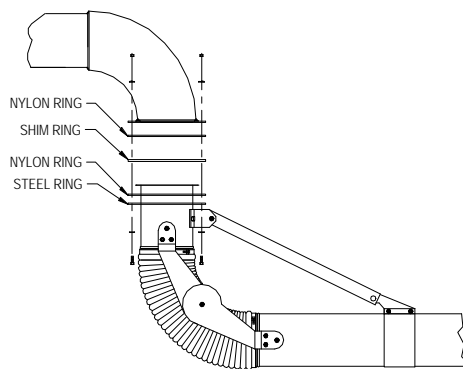

FIGURE 3

Note: Refer to the SCA 600/800 series Owner's Manual for detailed instructions to attach arm to Boom Arm.

6. Once the SCA 600/800 arm is attached to the Boom Arm, the control cable (if applicable) should be secured to the Boom Arm using cable ties and hose clamps (supplied) approximately as shown. Allow enough slack so SCA arm and Boom Arm can move freely (Figure 4).

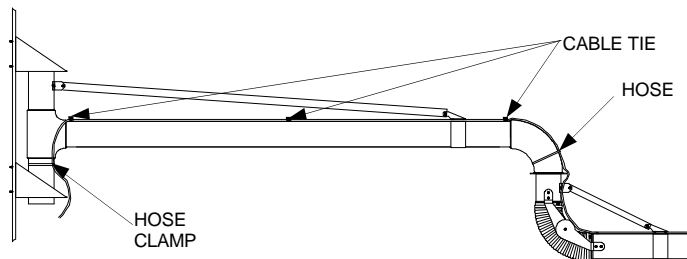
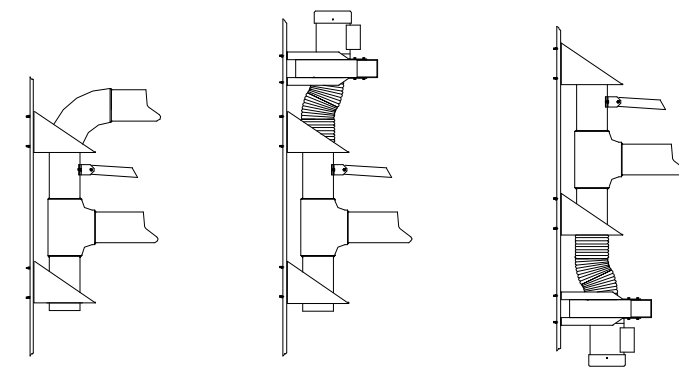

FIGURE 4

7. To add a blower to the system, locate the blower/motor assembly above the Boom Arm base. Connect the blower to the Boom Arm by means of a 6" or 8" dia. flexible duct. Typical applications are shown below (Figure 5).



METAL DUCT TO CONNECT TO CENTRAL BLOWER

BLOWER LOCATED ABOVE BOOM ARM

BLOWER LOCATED BELOW BOOM ARM

FIGURE 5

BOOM ARM PART LIST

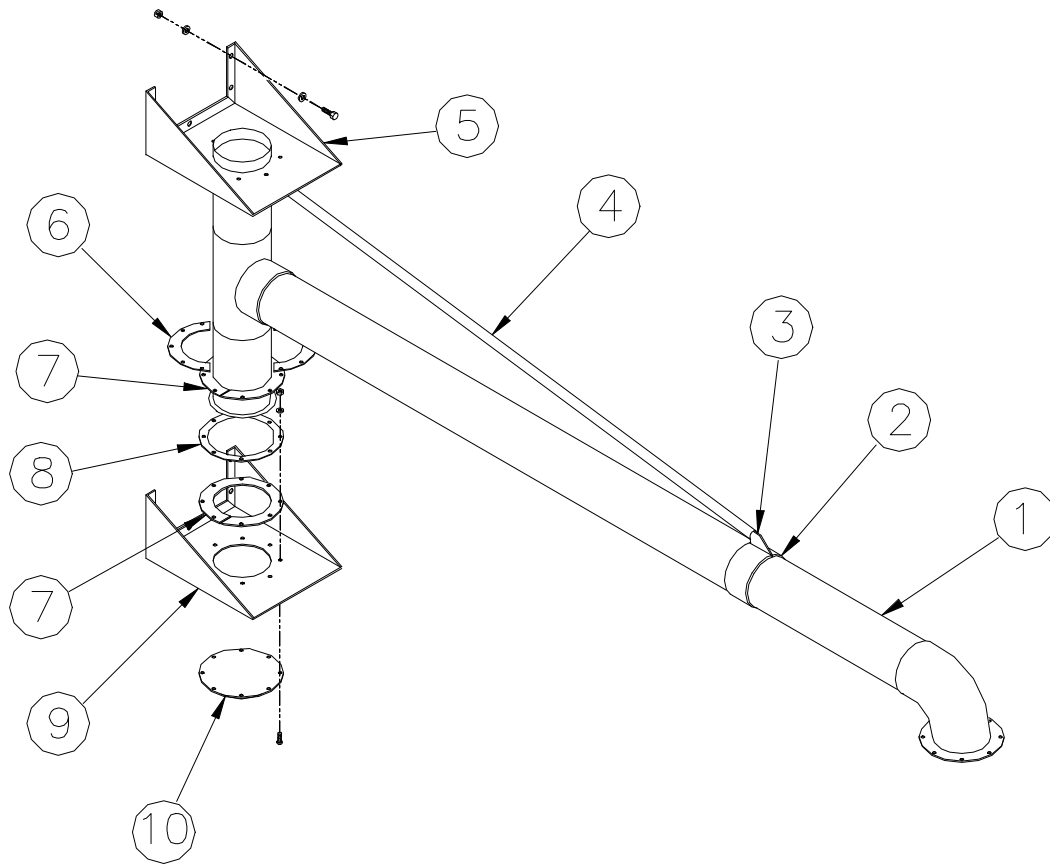

FIGURE 6

ITEM	PART NO. (6" ARM)	PART NO. (8" ARM)	DESCRIPTION	QUANTITY
1.	37001-01	37014-01	10' Arm Weldment	1
	37001-02	37014-02	14' Arm weldment	1
2.	36024-01	36024-02	Adjustable Support Clamp	1
3.	36026-01	36026-01	Anchor Support	1
4.	36011-02	36011-02	Fixed Arm Support	1
5.	36039-01	36039-02	Upper Gusset Weldment	1
6.	37004-01	37004-02	Half Ring	4
7.	36018-04	36060-04	Split Nylon Ring	4
8.	36018-05	36060-05	Shim Ring	1
9.	36017-01	36017-02	Lower Gusset	1
10.	37010-01	37010-02	Lower Seal Plate	1
NOT SHOWN	36085-01	36085-01	Single Pin Anchor Assembly	1

