

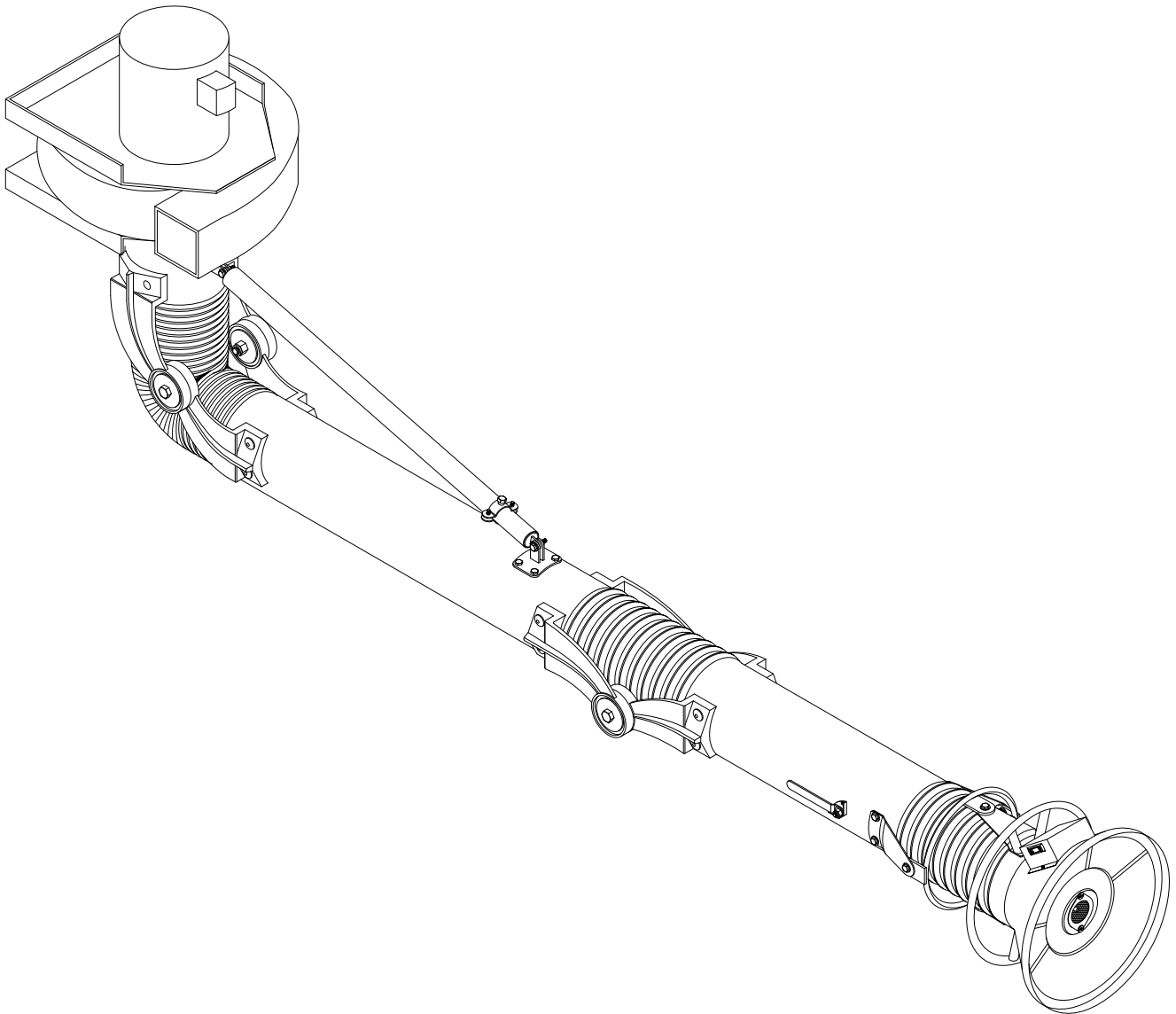

# MODEL SCA

Installation and Operation Manual



## **Important:**

This manual contains specific cautionary statements relative to worker safety. Read this manual thoroughly and follow as directed. It is impossible to list all the hazards of dust control equipment. All persons involved with the equipment or systems should be instructed how to operate in a safe manner.

**MODEL SCA SPECIFICATIONS**

**INPUT VOLTAGE:**

120V 60Hz 1 Phase  
230V 60Hz 1 Phase  
208-230V / 460V 60Hz 3 Phase

**EXHAUSTER BLOWER/MOTOR:**

TEFC 1 HP, 1 Phase - 12.0 Amps @ 120 VAC  
TEFC 1 HP, 3 Phase - 3.2 Amps @ 230 VAC  
TEFC 1 HP, 3 Phase - 1.6 Amps @ 460 VAC  
TEFC 3 HP, 3 Phase - 8.0 Amps @ 230 VAC  
TEFC 3 HP, 3 Phase - 4.0 Amps @ 460 VAC

**AIR FLOW:**

SCA400: 4" Dia. Arms - 1275 CFM, 1HP exhauster  
SCA600: 6" Dia. Arms - 1825 CFM, 1HP exhauster  
SCA600: 6" Dia. Arms - 2000 CFM, 3HP exhauster  
SCA800: 8" Dia. Arms - 2000 CFM, 3HP exhauster

**ARM LENGTH:**

5' - 4" Diameter  
7' - 4", 6" & 8" Diameters  
9' - 6" & 8" Diameters  
12' - 6" & 8" Diameters

**HOOD LAMP:**

12 V. Halogen @ 4 Amps (standard)

**WEIGHT:**

4" Dia. - 5' = 21 lbs.  
4" Dia. - 7' = 23 lbs.  
6" Dia. - 7' = 48 lbs.  
6" Dia. - 9' = 51 lbs.  
6" Dia. - 12' = 59 lbs.  
8" Dia. - 7' = 59 lbs.  
8" Dia. - 9' = 64 lbs.  
8" Dia. - 12' = 67 lbs.  
1 HP Motor/Blower Assembly = 45 lbs.  
3 HP Motor/Blower Assembly = 70 lbs.

**RANGE OF MOTION:**

See Figure 1. Factory set for "A" at 10 Deg. Moving the adjustment collar closer to the socket end of the pipe will reduce the amount of upward motion.

**Caution:**

**⚠ All electrical work must be done by a qualified electrician according to local, state and national codes.**

**⚠ Typical installations require that the blower or gusset assembly be mounted to a wall. Be sure that the wall is structurally sufficient to support the arm assembly being installed.**

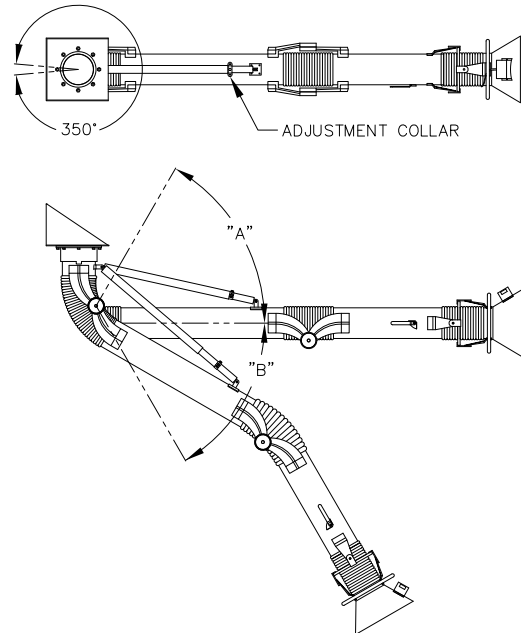

Arm Size	"A"	"B"
SCA405	40 Deg.	90 Deg.
SCA407	50 Deg.	90 Deg.
SCA607	38 Deg.	90 Deg.
SCA609	60 Deg.	90 Deg.
SCA612	60 Deg.	90 Deg.
SCA807	45 Deg.	90 Deg.
SCA809	70 Deg.	90 Deg.
SCA 812	68 Deg.	60 Deg.

Fig. 1

**PRE-OPERATING INSTRUCTIONS:**

1. Open cardboard carton(s) and remove unit. Remove packaging supports from arm assembly. Be careful not to dent the steel tubes on the arm during unpacking.
2. Inspect the unit for damage that may have been caused during shipping. Immediately report any such damage to the shipping carrier.
3. Examine the unpacked unit and compare it to the parts list description to verify that all components are received. If a component is missing from the assembly, contact your Micro Air representative.

**INSTALLATION:**

NOTE: Due to the numerous system combinations available, some of the following installation steps may not be applicable. Follow steps that directly address the specific system being installed.

1. Determine the location where the arm assembly will be installed (typically at a 10' height).
2. Drill holes into wall or support that align with the gusset or blower mount assembly. Attach the assembly to the wall using hardware provided (Fig. 2).

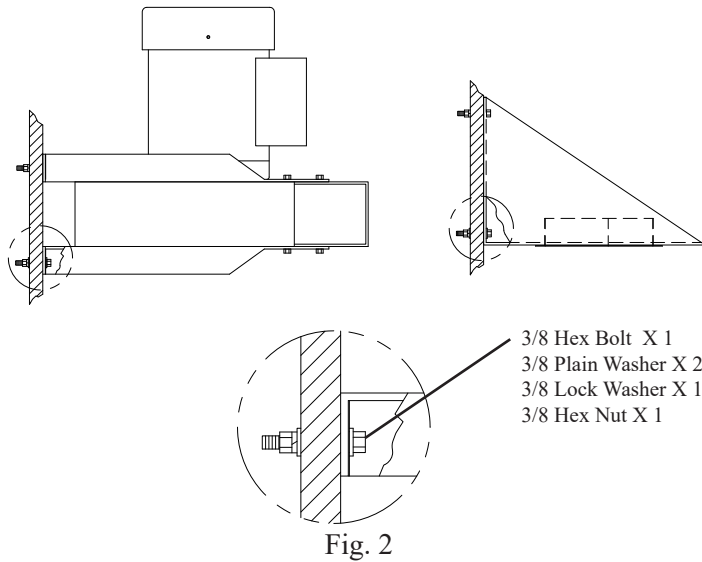

3. Attach the arm sub-assembly to the motor/blower or gusset assembly as shown (Fig. 3). It is recommended that two (2) people perform this step; one to support the arm assembly, while the other attaches hardware to clamp the arm assembly onto the motor/blower or gusset assembly.
4. Secure the control cable to the arm base using hose clamp. Allow enough slack so arm can move freely (Fig. 4).

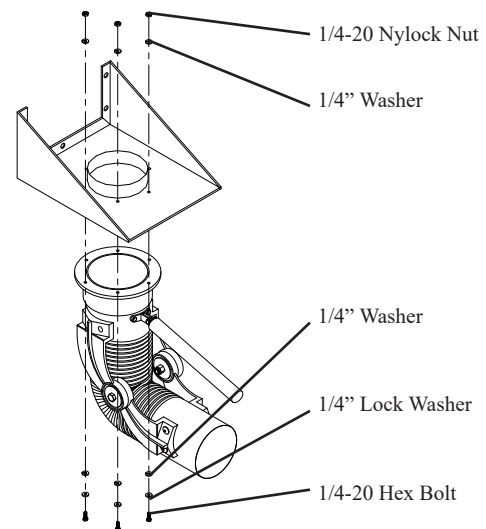
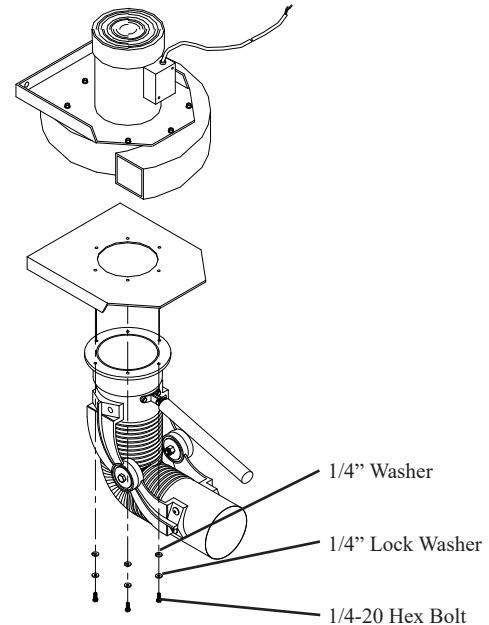

Fig. 3

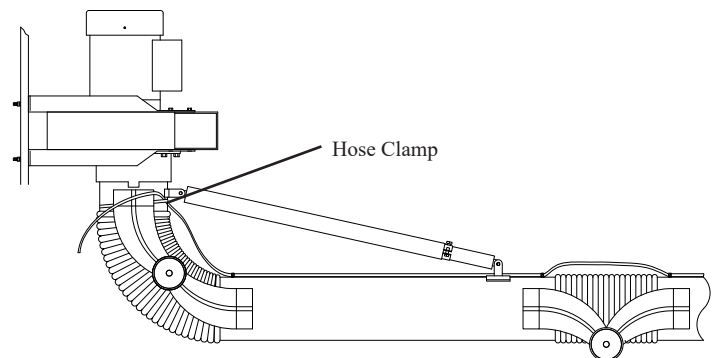

Fig. 4

**ELECTRICAL INSTALLATION:**

**Caution:**

**⚠ Installation can cause exposure to live parts. Disconnect electrical power before proceeding with installation.**

1. An electrical control box is included to house appropriate control transformers, relays, and motor starters. Locate the electrical control box and mount to wall or support, anywhere within reach of the arm control cable connector.
2. Connect the motor/blower power cord to the electrical control box (Fig. 5). The power cord is pre-wired to the motor blower.

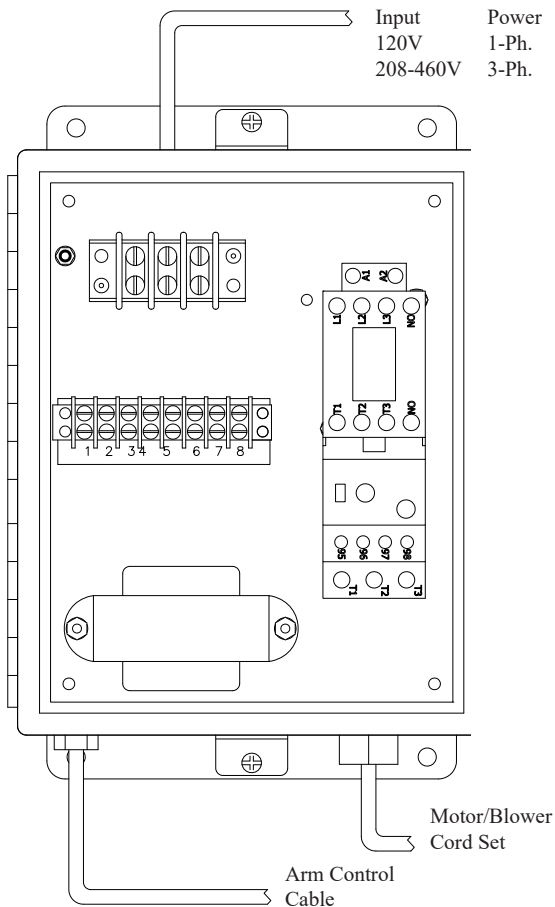

Fig. 5

3. Confirm that the motor wiring matches the supply voltage.
4. Confirm that the blower impeller wheel is rotating in the correct direction when energized (Fig. 6).
5. Connect the arm control cable to the electrical control box (Fig. 5). The arm control cable is pre-wired for turning the lamp on and/or the motor/blower on.

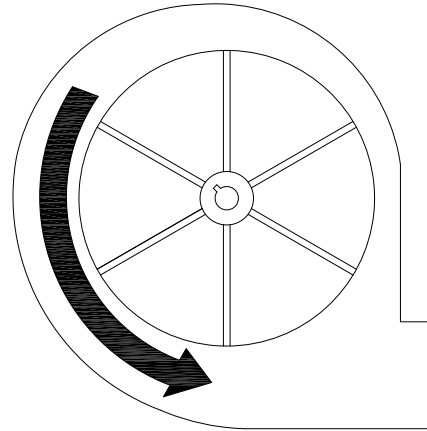

Fig. 6

6. Connect input power to the electrical box at the labeled terminal strip. Refer to specific wiring diagrams and Fig. 5 for details. Be sure to ground input to the electrical control box per local electrical codes.

**OPERATION:**

1. Upon completion of installation, the SCA should appear similar to the system shown in Fig. 7.
2. Grasp the hood handle and lift the lower arm section up and down. If the middle joint seems to tight, loosen the two nylock hex nuts that hold the joint together in 1/4-1/2 turn increments. If the arm has trouble maintaining a position, tighten the nuts.
3. The hood joint section can be manipulated up and down as well as right and left. If the joints are too loose or too tight, simply adjust the nylock hex nuts as needed.
4. To operate the blower, depress the fan switch located on the remote switch control box to ON. The blower motor will activate via a motor relay located inside the electrical control box.
5. Activate the lamp located inside the hood by depressing the lamp switch located on the remote switch control box.
6. The damper lever near the hood can be rotated 90 degrees to adjust the inlet air velocity.

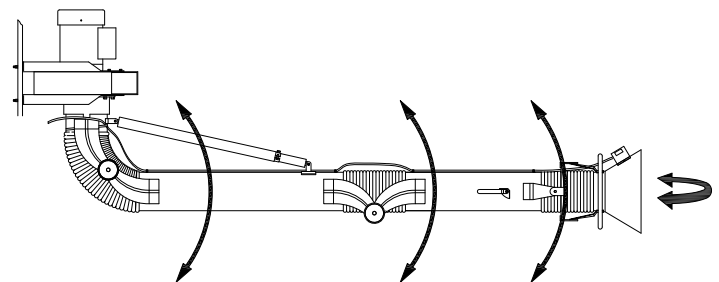

Fig. 7

**GENERAL MAINTENANCE:****Daily**

- Clean out any debris from the inner surface of the hood.
- Adjust any loose joints.

**Once per month**

- Grease the rotating socket with bearing grease listed to not react with Aluminum.

**Once per 3 months**

- Inspect the condition of the flexible hose for any opening that will allow air to flow through.
- Check the blower motor for bearing noise and impeller wheel for debris and dirt. No lubrication is required for the motor since it is a totally enclosed, fan cooled type, with permanently lubricated bearings.
- Inspect hardware for loose nuts and bolts around the swivel base area. Tighten as needed.
- Inspect all wiring for loose connections and cracked or cut insulation. Replace as needed.

**TROUBLE SHOOTING CHART**

CAUTION: BEFORE DISASSEMBLING THE UNIT OR DOING ANY INSPECTING OF THE PARTS, MAKE CERTAIN THAT THE POWER HAS BEEN CUT OFF AND THE BLOWER HAS COME TO A COMPLETE STOP.

PROBLEM	POSSIBLE CAUSE	REMEDY
Blower fails to start	No incoming power	Check line voltage
	Blown breaker or fuse	Replace fuse or throw breaker
	Primary voltage to motor contactor is below 10% tolerance	Take steps to increase voltage to primary
	Burned out motor	Replace motor
Unit runs slowly or inadequate capture velocity	Wired for wrong voltage or improper rotation	Check input voltage Check wiring diagram Switch L1 & L2 (3-phase only)
	Internal obstruction	Check if damper is open Check inlet for blockage Check hoses for proper connection Check hoses for holes
Vibration	Loose motor mount bolts	Tighten bolts
	Foreign objects in blower	Remove debris from blower
Stronger resistance during rotation of the arm	Lack of grease in the rotating socket	Grease the rotating socket
Arm will not stay where it is placed	The joints are loose	Tighten the joints

P2488-1

**SCA 600**  
**SCA 800**

INPUT VOLTAGE

120 VAC  
60 HZ.

LAMP: 12VAC.  
@ 4.0 AMPS

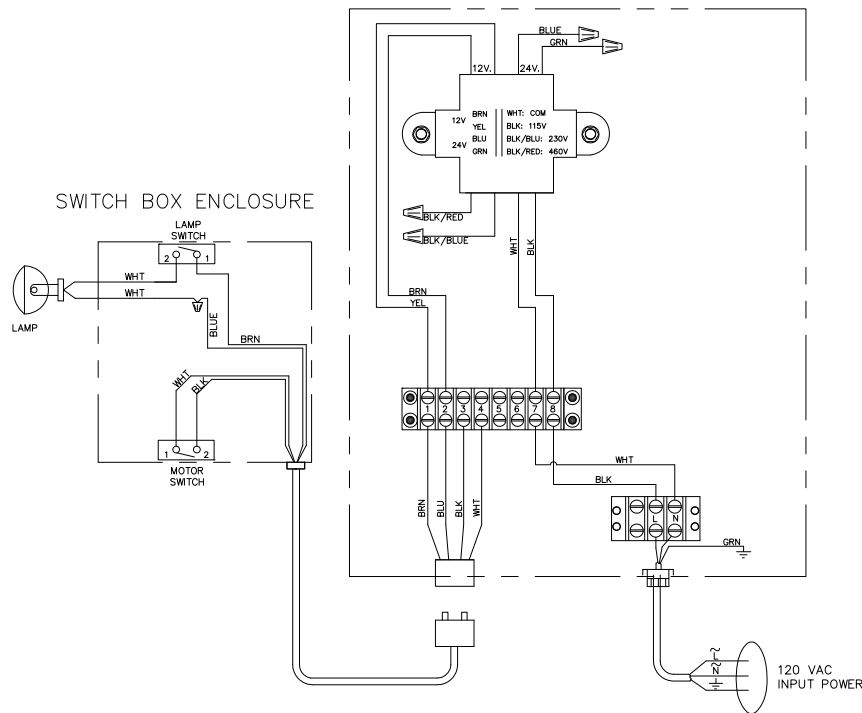

1. **CONNECT USING WIRE NUTS AND TAPE OFF. NO CONNECTION TO INPUT POWER.**
2. **NOTE: COMPONENTS & WIRE COLORS MAY VARY FOR SPECIFIC APPLICATIONS.**

METAL-FAB INC. WICHITA, KANSAS USA

**120 Volt Light Only Wiring Diagram**

P2486-1

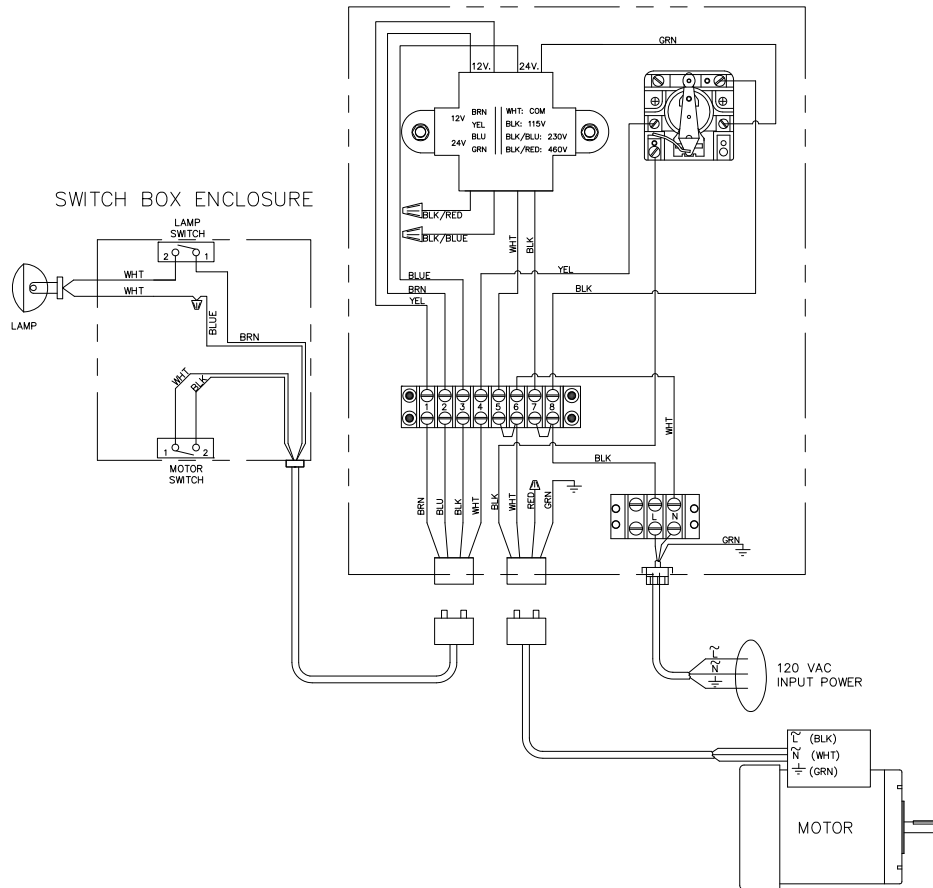

SCA 600  
SCA 800

INPUT VOLTAGE

120 VAC  
60 HZ.

MOTOR RATING

F.L.A. \_\_\_\_\_ @120 V  
H.P. \_\_\_\_\_

LAMP: 12VAC.  
@ 4.0 AMPS

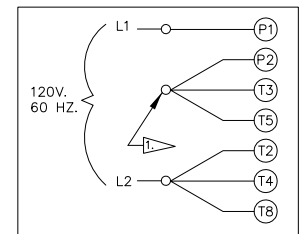

MOTOR CONNECTION

- CONNECT USING WIRE NUTS AND TAPE OFF. NO CONNECTION TO INPUT POWER.
- NOTE: COMPONENTS & WIRE COLORS MAY VARY FOR SPECIFIC APPLICATIONS.

METAL-FAB INC. WICHITA, KANSAS USA

120 Volt Light and Blower Wiring Diagram

P2487-1

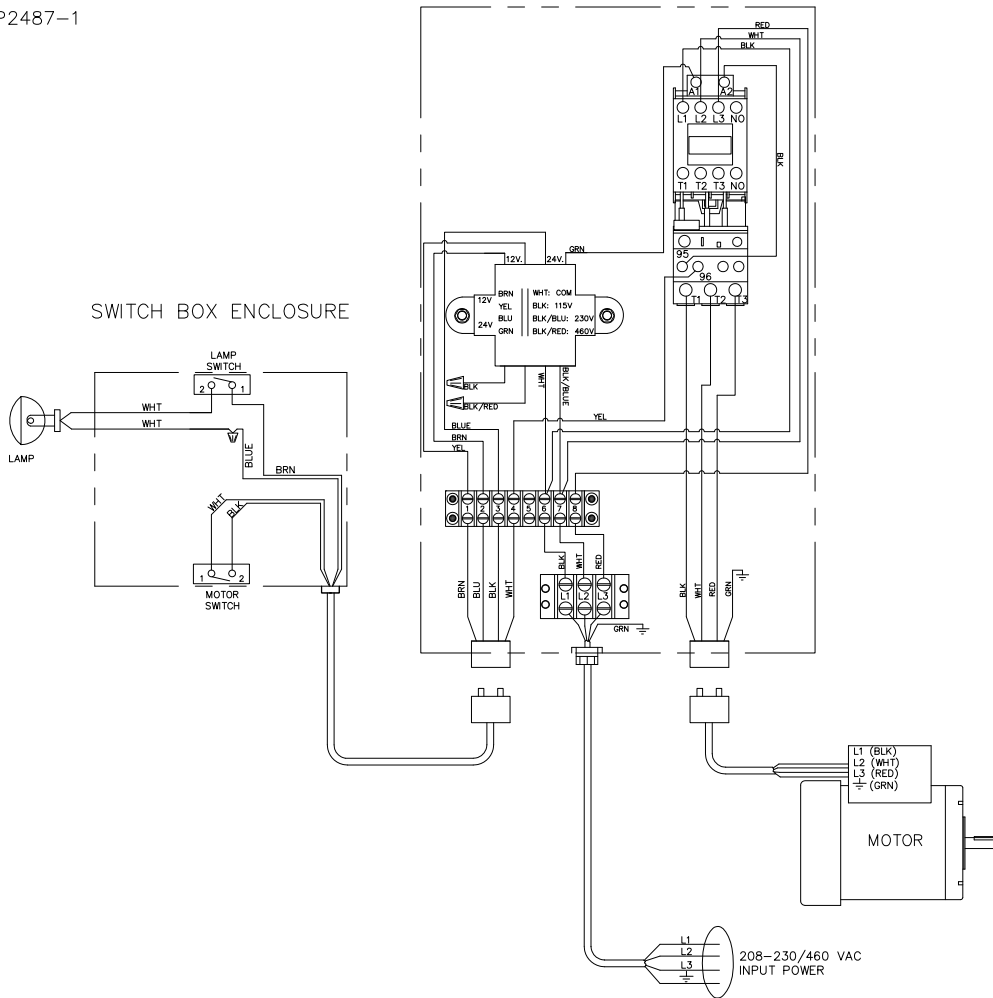

**SCA 600**  
**SCA 800**

**INPUT VOLTAGE (3 PH)**

208-230 VAC

460 VAC

50 HZ.

60 HZ.

**MOTOR RATING**

F.L.A. \_\_\_\_\_

H.P. \_\_\_\_\_

LAMP: 12VAC  
@ 4.0 AMPS

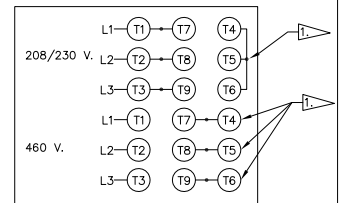

**MOTOR CONNECTION**

▶ CONNECT USING WIRE NUTS AND TAPE OFF. NO CONNECTION TO INPUT POWER.

2. NOTE: COMPONENTS & WIRE COLORS MAY VARY WITH SPECIFIC APPLICATIONS.

METAL-FAB INC. WICHITA, KANSAS USA

**208/230/460 Volt Light and Blower Wiring Diagram**



**SCA400 ARM ASSEMBLY PARTS LIST**

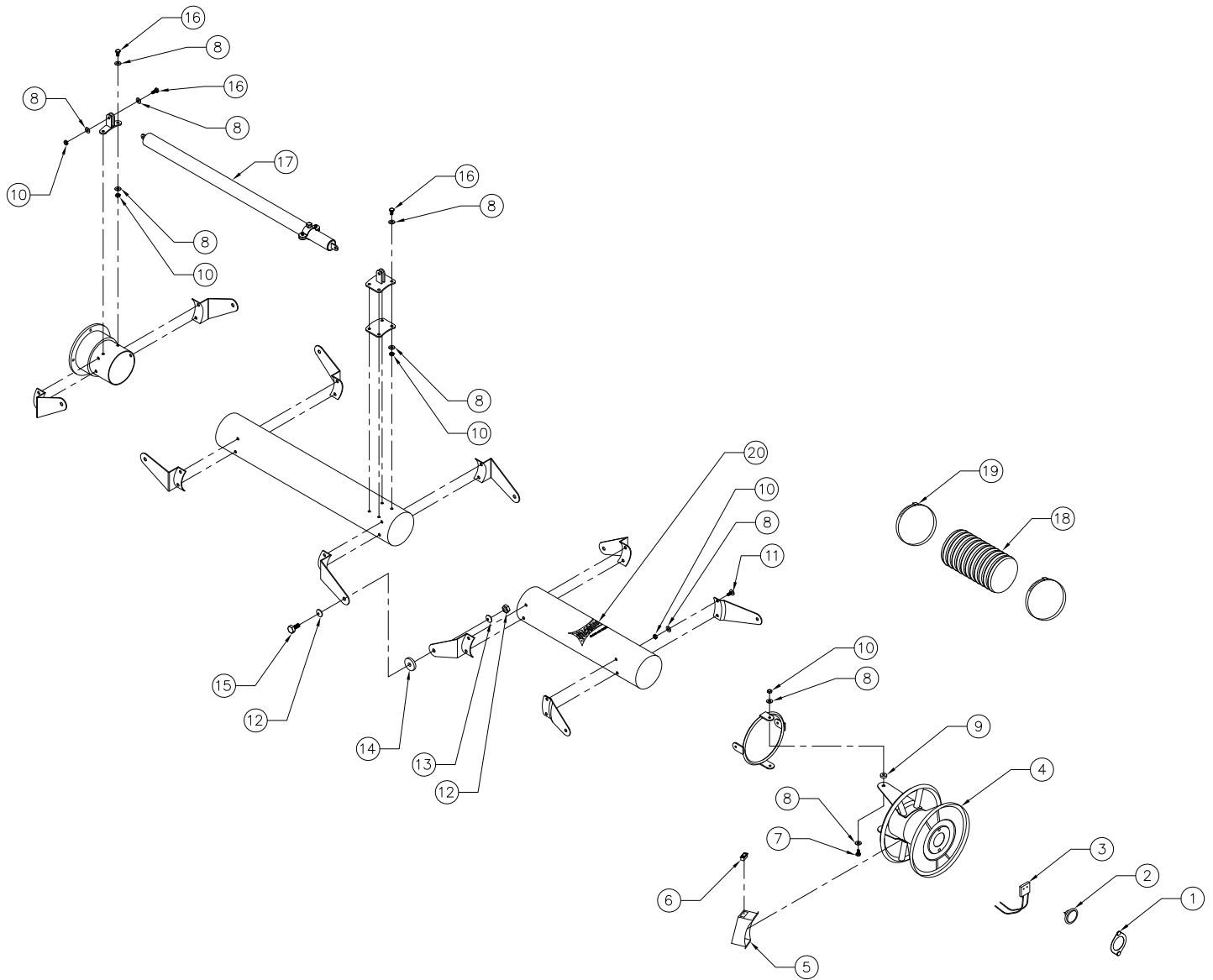

ITEM	PART NO.	DESCRIPTION	ITEM	PART NO.	DESCRIPTION
1.	37107-01	Lamp Plate	12.	P2484	5/16" Nylock Hex Nut
2.	P2170	Lamp	13.	P2465	Cup Washer
3.	P2168	Lamp Socket	14.	P2464	Friction Pad
4.	P2463	Hood Assembly	15.	P2614	5/16-18 x 1" Hex Head Bolt
5.	37106-01	Switch Box	16.	P164	1/4-20 x 3/4" Hex Head Bolt
6.	P2219	Rocker Switch	17.	P2457	4" Arm Spring Shock
7.	P2483	1/4-20 x 1" Hex Head Bolt	18.	P2470	4" Dia. Flex Hose
8.	P246	1/4 Flat Washer	19.	P2232	Hose Clamp
9.	P2482	Hood Disc Pad	20.	P2312	Micro Air Decal
10.	P2485	1/4-20 Nylock Hex Nut	N/S	P2471	4 Conductor Cable - 9' long
11.	P2490	1/4-20 x 1" Carriage Bolt	N/S	P2472	4 Conductor Cable - 15' long

**SCA600 & SCA800 ARM ASSEMBLY PARTS LIST**

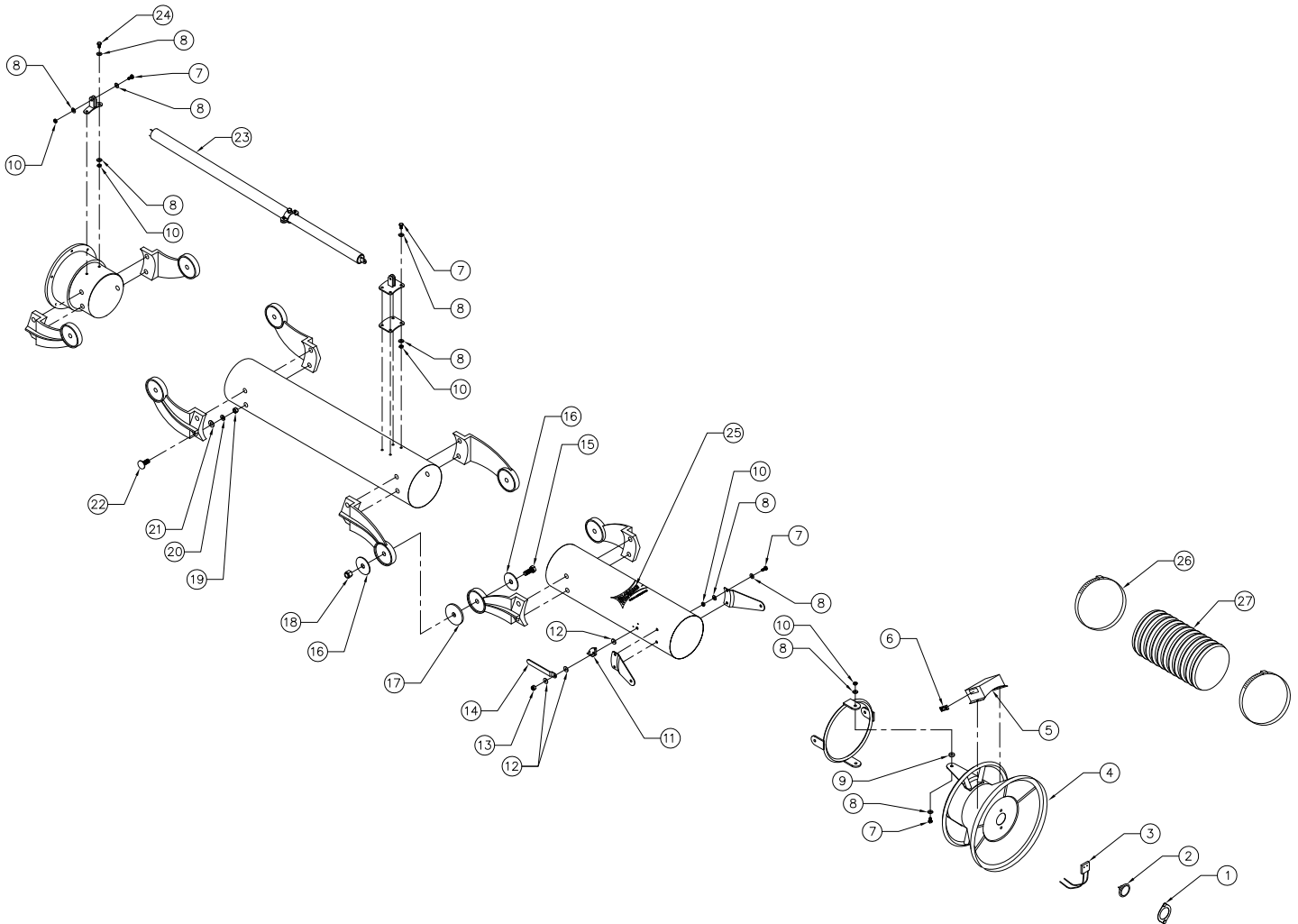

ITEM	PART NO.	DESCRIPTION	ITEM	PART NO.	DESCRIPTION
1.	37107-01	Lamp Plate	18.	P2479	1/2-13 Nylock Hex Nut
2.	P2170	Lamp	19.	P141	3/8-16 Hex Nut
3.	P2168	Lamp Socket	20.	P142	3/8 Lock Washer
4.	P2466	6" Hood Assembly	21.	P2206	Flat Washer
	P2469	8" Hood Assembly	22.	P2481	3/8-16 x 1.25" Carriage Bolt
5.	37106-01	Switch Box	23.	P2458	7' & 9' Arm Spring Shock
6.	P2219	Rocker Switch		P2459	12' Arm Spring Shock
7.	P164	1/4-20 x 3/4" Hex Head Bolt	24.	P2483	1/4-20 x 1" Hex Bolt
8.	P246	1/4 Flat Washer	25.	P2312	Micro Air Decal
9.	P2482	Hood Disc Pad	26.	P2232	Hose Clamp
10.	P2485	1/4-20 Nylock Hex Nut	27.	P2491	6" Dia. Flex Hose
11.	37104-01	Damper Handle Stop Plate		P2617	8" Dia. Flex Hose
12.	P2206	5/16" Flat Washer	N/S	P2471	4 Conductor Cable - 9' long
13.	P2484	5/16" Nylock Hex Nut	N/S	P2472	4 Conductor Cable - 15' long
14.	37103-01	Damper Handle	N/S	P2473	4 Conductor Cable - 18' long
15.	P2478	1/2-13 x 2.25" Hex Head Bolt			
16.	P2468	Cup Washer			
17.	P2467	Friction Pad			

**SCA ELECTRICAL CONTROL BOX PARTS LIST**

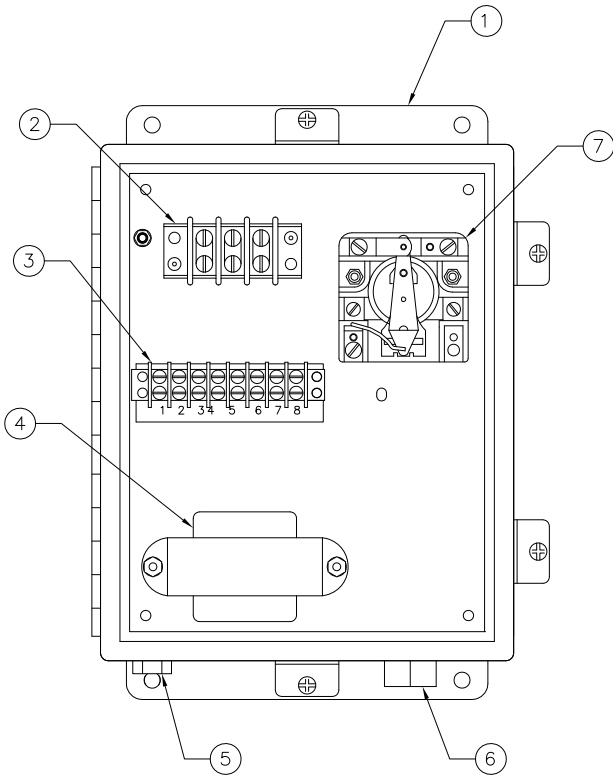

**SINGLE PHASE CONTROL BOX**

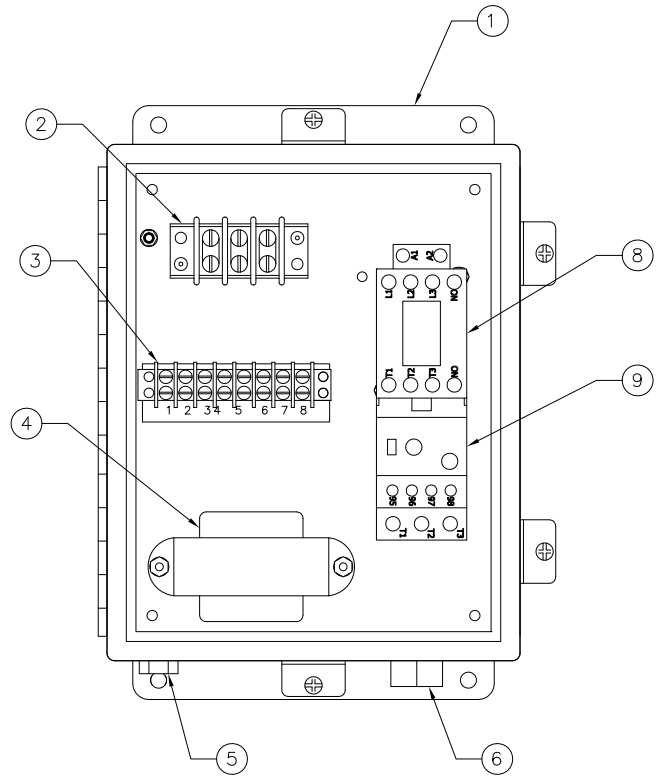

**3-PHASE CONTROL BOX**

ITEM	PART NO.	DESCRIPTION
1.	P7318	Nema 4 Control Box
2.	P445	3 Conn. Terminal Strip
3.	P3246	8 Conn. Terminal Strip
	P3252	Terminal Strip Label
4.	P2534	Transformer
5.	P2474	Arm Control Wiring Harness
N/S	P2475	Arm Control wiring Harness Hex Nut
6.	P2477	Motor Control Wiring Harness
7.	P2078	Relay
8.	P3909	Contactors
9.	P3914	Overload (1HP)
	P3915	Overload (3HP)

**BLOWER ASSEMBLY PARTS LIST**

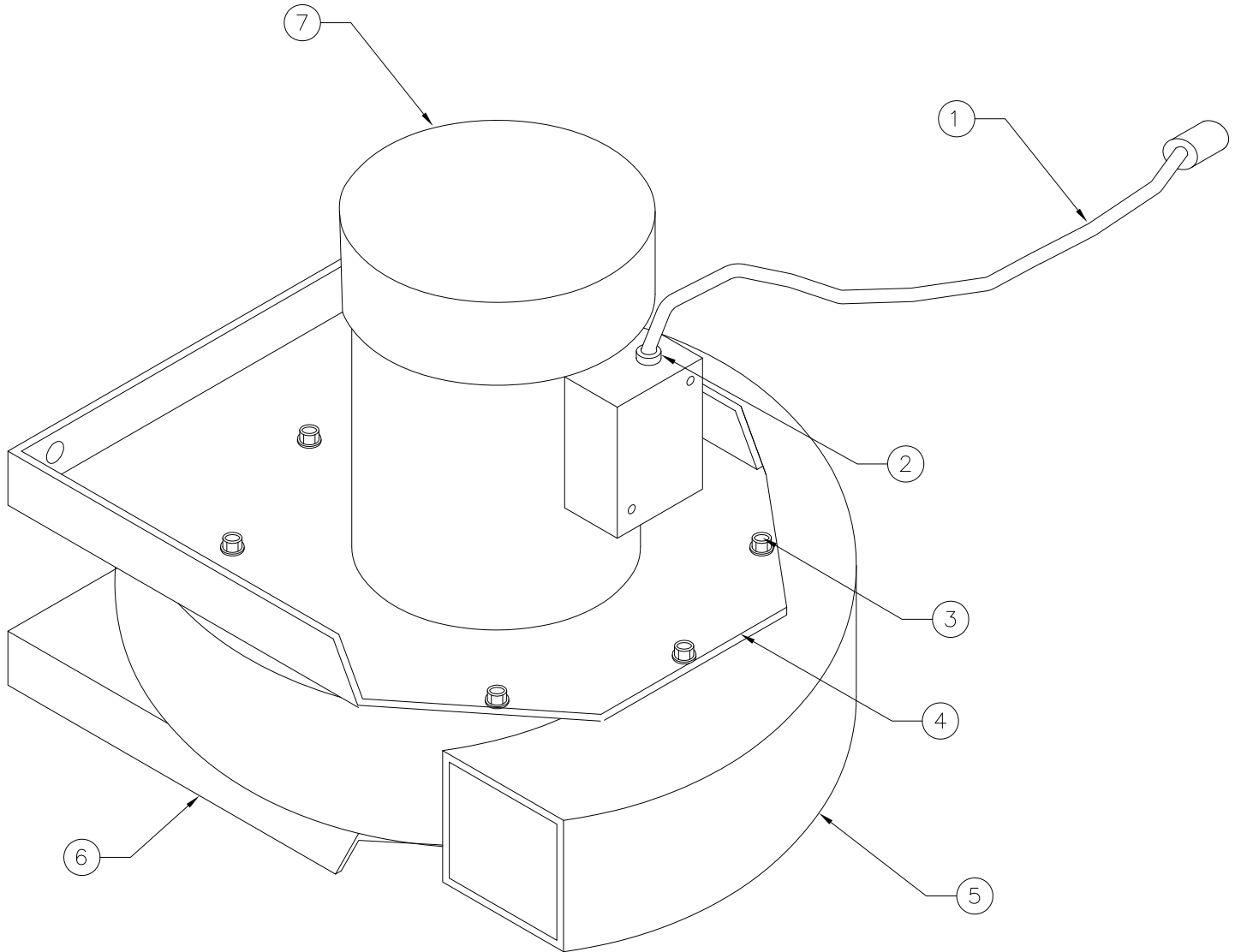

**1 HP. BLOWER ASSEMBLY**

ITEM	PART NO.	DESCRIPTION
1.	P2473	Motor Cable
2.	P386	Strain Relief
3.	P2729	#12 x 3/4" Drive Screw
4.	37111-02	Motor Mount Plate (1-Phase)
	37111-05	Motor Mount Plate (3-Phase)
5.	P2761	Blower
6.	37111-01	4" Swivel Plate
	37111-03	6" Swivel Plate
7.	P2077	1 HP. Single Phase Motor
	P2249	1 HP. 3-Phase Motor

**3 HP. BLOWER ASSEMBLY**

ITEM	PART NO.	DESCRIPTION
1.	P2473	Motor Cable
2.	P386	Strain Relief
3.	P2729	#12 x 3/4" Drive Screw
4.	37111-05	Motor Mount Plate (3-Phase)
5.	P2715	Blower
6.	37111-06	6" Swivel Plate
	37111-04	8" Swivel Plate
7.	P2716	3 HP. 3-Phase Motor

